



ANTONIO CARRARO

serie 30

use and maintenance



TTR 4400

Congratulations!

You have made an excellent choice.

Your machine has been built according to the most advanced techniques of design and manufacturing.

Antonio Carraro machines are so versatile that they can be used equally well in farming, in industry and in local government departments.

The high technological standard and the international competitiveness of the Antonio Carraro trademark are synonymous with development programmes that aim to confirm the Company's role as a leader in its field and also as a flourishing firm with a strong leaning for innovation.

TRACTORTOOLS
DIRECT



serie 30

TIGRETRAC TTR 4400

TIGRETRAC TTR 4400 4WS

TRACTORTOOLS
DIRECT

use and maintenance

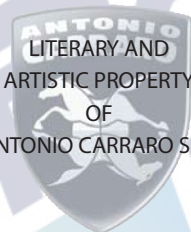

LITERARY AND
ARTISTIC PROPERTY
OF
ANTONIO CARRARO SpA

Reproduction of text and illustrations,
even in part, is prohibited

Instructions, features, technical data and diagrams considered necessary for proper use, knowledge and ordinary maintenance of the «**TIGRETRAC TTR 4400**» are contained herein.

This does not constitute a thorough description of the different machine elements nor a detailed account of their operation. The user will however find all that is needed for the safe use of the machine and maintenance of the different parts.

The use instructions and the maintenance regulations refer to regular service requirements that can however vary in the different operating conditions. Proper functioning, durability and service economization of the machine depend on the strict observance and fulfilling of the above.

The warranty granted by Antonio Carraro spa can be automatically annulled in case of improper use or non-observance of the above.

Repairs or reconditioning that involve complex operations must be carried out by an authorized Carraro Service Centre which avails itself of qualified personnel.

Antonio Carraro spa, through its authorized Carraro Service Centres, is however readily available to provide accurate technical assistance and all that is necessary to ensure the proper operation and performance of the machine.

The main features and the use instructions for the engine are written in the relative operating and maintenance manual supplied together with this manual.

Antonio Carraro spa reserves the right to change the design of the machine without updating this paper. Data, descriptions and drawings are supplied without any commitment and simply for the sake of information.

Antonio Carraro spa declines any responsibility for possible inexactitudes contained in this booklet due to printing or transcription errors.

For maximum machine performance and durability use only Antonio Carraro spa Spare Parts. Simply order them by consulting our spare parts catalogue.

Antonio CARRARO spa
Via Caltana, 24
35011 CAMPODARSEGO (Padova) Italy
Tel. 049/9219921
Fax 049/9219999

MACHINE DATA

Type of machine Serial number Manufacturing year

1. General	5	4. Safety regulations	17	6.3.12.1 Front power lift.....	37
1.1 Definition.....	5	4.1 General safety regulations.....	17	6.3.12.2 Rear 3-point elevator.....	37
1.2 Identification.....	5	4.1.1 Clothing.....	17	6.3.13 Hydraulic couplings.....	38
2. Technical features	6	4.1.2 Driver's seat.....	17	6.3.14 Tow-hooks.....	38
2.1 Overall dimensions.....	7	4.1.3 Environment, pollution.....	18	6.3.15 Reversibility.....	39
2.2 Tires.....	8	4.1.4 Coupling of implements.....	18	6.3.16 Air conditioning system.....	42
2.3 Engine and weights.....	9	4.1.5 Driving on public roads.....	19	7. Maintenance	44
2.4 Speed.....	10	4.1.6 Safety devices.....	19	7.1 General.....	44
2.5 Clutch.....	11	4.1.7 Decals.....	19	7.2 Engine.....	44
2.6 Gearbox.....	11	4.1.8 Power take-off.....	19	7.2.1 Air filter.....	44
2.7 Front axle.....	11	4.1.9 Universal shaft.....	19	7.2.2 Cooling circuit.....	45
2.8 Rear axle.....	11	4.1.10 Safe use.....	20	7.3 Wheels.....	45
2.9 Drive.....	11	4.1.11 Use on slopes and uneven grounds.....	20	7.4 Windscreen wash liquid tank (on machines equipped with cab).....	46
2.10 Front power take-off (optional).....	11	4.1.12 Maintenance.....	21	7.5 Clutch.....	46
2.11 Rear power take-off.....	11	4.1.13 Refuelling.....	21	7.5.1 Clutch adjustment.....	46
2.12 Service brake.....	11	5. Machine description	22	7.6 Front and rear transmission.....	46
2.13 Emergency and parking brake.....	11	5.1 Machine description.....	22	7.6.1 Front transmission.....	46
2.14 Steering.....	11	5.1.1 Decals.....	23	7.6.2 Rear transmission.....	47
2.15 Reversibility.....	12	5.1.2 Controls and instruments.....	24	7.7 Hydraulic elevator oil filter.....	47
2.16 Seat.....	12	5.1.3 Control panel.....	27	7.8 Hydrostatic engine oil filter.....	48
2.17 Driver's seat.....	12	5.1.4 Seat.....	28	7.9 Brakes.....	48
2.18 Body work.....	12	5.1.5 Cab instruments.....	29	7.9.1 Brake adjustment.....	48
2.19 Power-lift.....	12	6. Use instructions	31	7.9.2 Hydraulic brakes.....	49
2.20 Tow-hook.....	12	6.1 General rules.....	31	7.9.2.1 Adjusting the brakes.....	49
2.21 Refuelling.....	13	6.2 Before use.....	31	7.9.2.2 Bleeding the brakes' hydraulic circuit.....	50
2.22 Electrical system.....	13	6.3 Use of machine.....	31	7.10 Electrical system.....	51
2.23 Illumination and signalling devices.....	13	6.3.1 Starting engine.....	31	7.10.1 Battery.....	51
2.24 Instruments and accessories.....	13	6.3.2 Starting engine at low temperatures.....	32	7.10.2 Lights.....	51
2.25 Hydraulic system.....	13	6.3.3 Turning off the engine.....	32	7.10.2.1 Replacing the lamps.....	52
2.26 Windscreen washing liquid tank.....	13	6.3.4 Starting the machine.....	32	7.10.3 Fuses.....	54
2.27 Hydraulic couplings (optional).....	14	6.3.5 Gearshift.....	33	7.10.4 Electric system.....	55
2.28 Air filter.....	14	6.3.6 While running.....	33	7.10.4.1 General wiring diagram and components.....	55
2.29 Water radiator.....	14	6.3.7 Stopping the machine.....	33	7.10.4.2 Cab components and wiring diagram.....	60
2.30 Exhaust pipe protection.....	14	6.3.8 Power take-off.....	33	7.10.4.3 Wiring diagram and components of 4WS steering.....	62
2.31 Hood opening.....	15	6.3.8.1 Front power take-off (optional).....	33	7.11 Lubrication.....	63
2.32 Fuel tank.....	15	6.3.8.2 Rear power take-off (independent).....	34	7.11.1 Maintenance table.....	64
2.33 Battery.....	15	6.3.9 Wheel drive.....	34	7.12 Troubleshooting.....	69
2.34 Sound level.....	15	6.3.10 Locking the differentials.....	34	8. Spare parts	71
3. Machine transportation and haulage	16	6.3.11 Hydraulic steering (Tigretrac 4WS).....	35	8.1 Spare parts.....	71
3.1 Transportation and haulage.....	16	6.3.11.1 Safety system.....	36		
3.2 Machine standard equipment.....	16	6.3.12 Hydraulic power lift.....	36		

1.1 DEFINITION

TIGRETRAC TTR 4400 are machines defined as farming tractors.

To avoid misunderstanding we wish to point out that “Front” indicates the engine side, whereas “Rear” is the side opposite the engine.

The term “Right” or “Left”, indicated in the description, is understood looking at the machine from the rear.

1.2 IDENTIFICATION

The machine chassis type and number are stamped on the main body (Fig. 1) as well as on the name-plate (Fig. 2). The engine's serial number is stamped on a name-plate (see engine instructions manual).

On the name-plate are marked:

- **type of machine**
- **serial number of machine**

These data should be copied in the appropriate space at the beginning of the manual.



Fig. 1

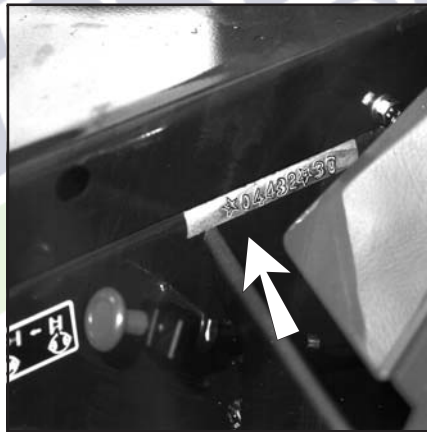

Fig. 2

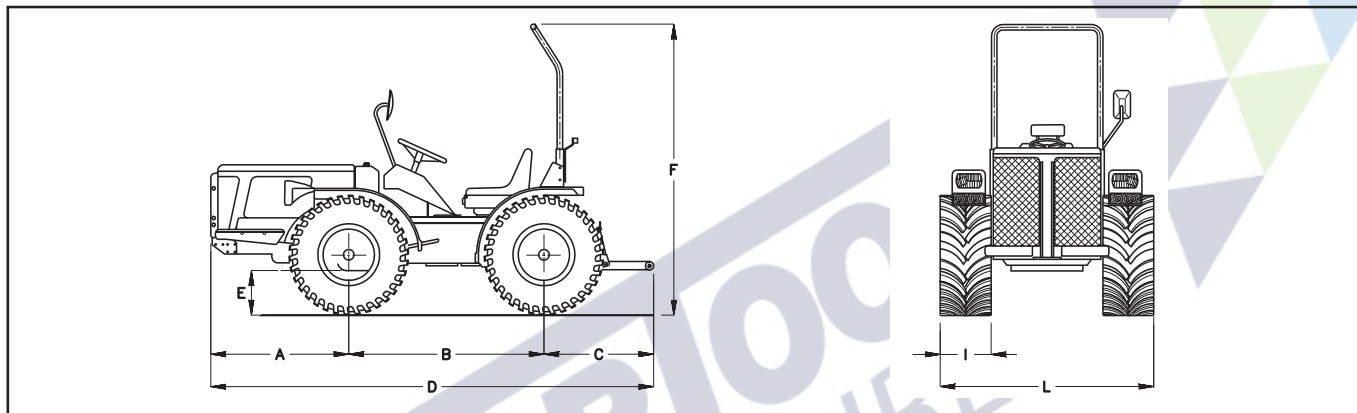

Fig. 3 - Tigretrac

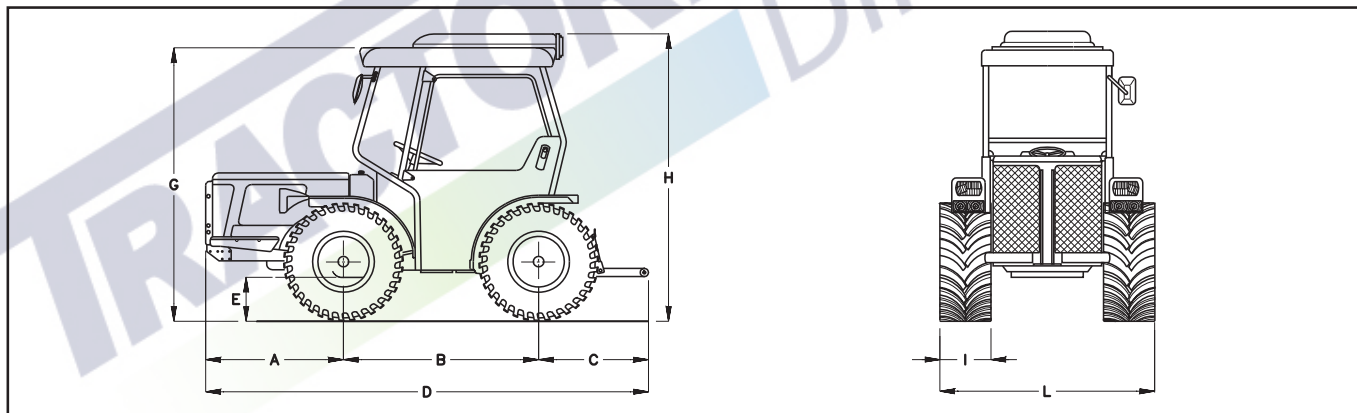

Fig. 4 - Tigretrac with 4-upright frame

2. TECHNICAL FEATURES

2.1 OVERALL DIMENSIONS

	TTR 4400			TTR 4400 4WS	
	with arch	with frame	with cab	with frame	with cab
A	940	940	940	940	940
B	1300	1300	1300	1300	1300
C	760	760	760	680	680
D	3110	3110	3110	3030	3030
F	2010 ÷ 2040				
G		1895 ÷ 1925		1895 ÷ 1910	
H			2000 ÷ 2030		2000 ÷ 2015

2.2 TIRES

TTR	E	I	L	L (4 brakes)
7.5L - 15	210	210	1165÷1300	1180÷1300
			1100÷1290	1100÷1290
29x12.00 - 15	205	295	1365	1340
			1350	1350
29x12.50 - 15	210	310	1380	1355
			1365	1365
6.50 - 16	215	180	1125÷1280	1135÷1290
			1060÷1270	1060÷1270
28x9.00 - 15	200	235	1220÷1265	1260÷1275
			1165÷1255	1165÷1255
7.50 - 16	230	210	1165÷1300	1185÷1300
			1100÷1290	1100÷1290

TTR 4WS	E	I	L
7.5L - 15	210	210	1350
			1355
29x12.00 - 15	205	295	1535
			1510
29x12.50 - 15	210	310	1550
			1525
6.50 - 16	215	180	1280 ÷ 1335
			1290 ÷ 1345
28x9.00 - 15	200	235	1380 ÷ 1440
			1360 ÷ 1415

2. TECHNICAL FEATURES

2.3 ENGINE AND WEIGHTS

	TIGRETRAC TTR 4400	TIGRETRAC TTR 4400 4WS
Diesel engine type	4-stroke	4-stroke
No. of cylinders	3	3
Engine power (cm ³)	1642	1642
Power (kW)	28	28
Max. R.P.M.	3000	3000
Max torque (Nm/g)	116 - 1800	116 - 1800
Cooling	Water	Water
Tank capacity (lt)	35	35
Transmission	Hydrostatic gearbox	
WEIGHT IN RUNNING ORDER WITH DRIVER (75 kg) WITH ARCH		
Total (kg)	1070 ÷ 1110	-
Front axle (kg)	655 ÷ 675	-
Rear axle (kg)	415 ÷ 435	-
WEIGHT IN RUNNING ORDER WITH DRIVER (75 kg) WITH FRAME		
Total (kg)	1225 ÷ 1265	1280 ÷ 1320
Front axle (kg)	730 ÷ 750	745 ÷ 765
Rear axle (kg)	495 ÷ 515	535 ÷ 555
WEIGHT IN RUNNING ORDER WITH DRIVER (75 kg) WITH CAB		
Total (kg)	1300 ÷ 1340	1355 ÷ 1395
Front axle (kg)	770 ÷ 790	785 ÷ 805
Rear axle (kg)	530 ÷ 550	570 ÷ 590

2.4 SPEED

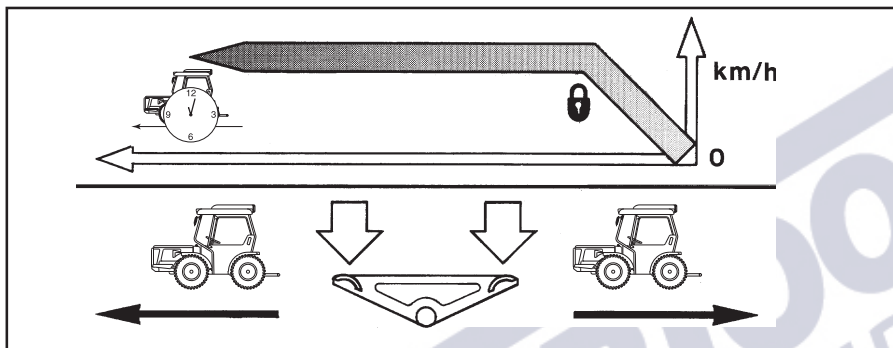

Fig. 5



WARNING. When operating the rocker pedal (Fig. 5), if you press on the front arm the machine moves forward, if you press on the rear arm the machine moves in reverse.

To maintain a constant speed, lock the pedal using the SPEED-FIX device.

Speed (km/h) at 3000 rpm AV – RM	TTR 4400			TTR 4400 4WS		
	Slow	Normal	Fast	Slow	Normal	Fast
Tires 7.5L - 15	5,65	12,00	25,50	5,65	12,00	25,50
Tires 29x12.00 - 15	5,68	12,08	25,66	5,68	12,08	25,66
Tires 29x12.50 - 15	5,71	12,13	25,77	5,71	12,13	25,77
Tires 6.50 - 16	5,73	12,18	25,87	5,73	12,18	25,87
Tires 28x9.00 - 15	5,78	12,29	26,12	5,78	12,29	26,12
Tires 7.50 - 16	6,14	13,05	27,72			

2.5 CLUTCH

Dry, single-plate with mechanical pedal control.

2.6 GEARBOX

Hydrostatic type. With stepless change of feed speed in both directions from 0 to 6,1 km/h with selector in the “slow” position and from 0 to 13,1 km/h with selector in the “regular” position and from 0 to 27,7 km/h with selector in the “fast” position. Possibility of locking the speed variator control in any position by means of the «SPEED-FIX» device.

See speed table 2.4 for the different speeds.

2.7 FRONT AXLE

Steered wheel front axle with differential locking device.

2.8 REAR AXLE

Fixed on TTR 4400; steered-wheel type on TTR 4400 4WS. Equipped with differential locking device.

2.9 DRIVE

Four-wheel drive with rear wheel drive disengagement on TTR 4400 (not installed on TTR 4400 4WS).

2.10 FRONT POWER TAKE-OFF (Optional)

With spline shaft ASAE 1-3/8” profile (34.9 mm), with independent electro-hydraulic control, standard speed 1000 r.p.m. with engine at 2500 r.p.m. (Fig. 6). Clockwise rotation.



Fig. 6

2.11 REAR POWER TAKE-OFF

With grooved shaft, ASAE 1 - 3/8” profile (34,9 mm), independent, two speeds 540 and 1000 r.p.m. respectively with engine at 2500 and 2460 r.p.m. (2 Fig. 8-9), clockwise rotation direction.

2.12 SERVICE BRAKE

- Mechanical with simultaneous reaction and pedal control on rear wheels (axle gearbox side).
- (Optional) With double-circuit hydraulic pedal control acting on the 4 wheels.

2.13 EMERGENCY AND PARKING BRAKE

Hydrostatic emergency brake with pedal control. Parking brake with lever control, on the rear wheels (axle gearbox side).

2.14 STEERING

Hydrostatic with «LOAD SENSING» valve.

Min. steering radius:

Tigretrac TTR 4400	m	3
Tigretrac TTR 4400 4WS:		
- with two steering wheels.....	m	4
- with 4 steering wheels	m	2.5

2.15 REVERSIBILITY

Double pedals and revolving control centre for the immediate and automatic reversibility of the driver's seat.

2.16 SEAT

Cushioned with springing system and vertical and horizontal adjustable positions.

2.17 DRIVER'S SEAT

Rotating control centre for the immediate and automatic reversibility of the driver's seat.

Protection frame with 4 uprights mounted on "Silent Block" with top. The front and rear windscreens can be opened, front and rear electric wipers, two work lights and rear view mirror.

Upon request driver's cab mounted on "Silent Block" with 2 frames, top and doors. The front and rear windscreens can be opened, front and rear electric wipers and windscreen washers, two work lights, courtesy lamp, rear view mirror, soundproofing with heating system.

2.18 BODY WORK

Hood can be opened on side, muffler protection, mudguard on four wheels.

2.19 POWER LIFT

- Rear with two hydraulic jacks and three-points hitch. Cat. 1. Maximum lifting load 850 kg. normal lifting, 1100 kg double-acting hoisting (upon request).
- Front (on request) with two hydraulic jacks, maximum lifting load 400 kg.

2.20 TOW-HOOK

- On front side (optional), fixed pin tow-hook (1 Fig. 7) only for machine towing.
- On the rear, for towing trailers and equipment, fixed pin type (3 Fig. 8), or CBM tow-hook (4 Fig. 9). The latter hook differs from the standard rigid hook because it can rotate on its longitudinal axis.

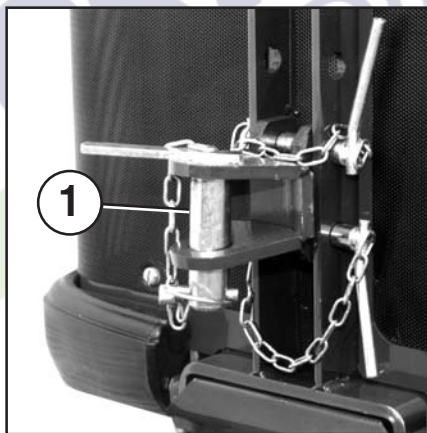

Fig. 7

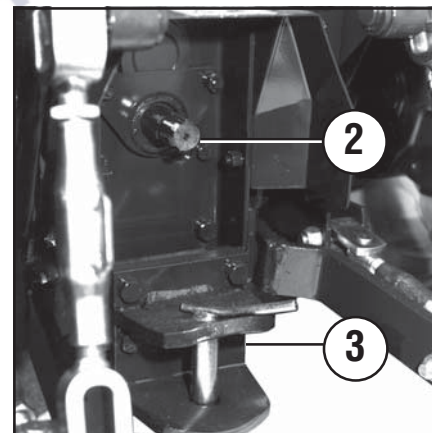

Fig. 8

2.21 REFUELLING

- Fuel tank (diesel oil):lt 35
- Engine oil (see separate use and maintenance manual).
- Cooling circuit (arch-chassis):lt 7.6
- cooling circuit (cab):lt 8.4
- Oil for box on engine side:lt 6.5
- Oil for gearbox:.....lt 8.5
- Windscreen wash liquid tank (5 Fig. 10)

2.22 ELECTRICAL SYSTEM

- Voltage: 12 Volt.
- Battery: 12 V, capacity 70 Ah
- Alternator with voltage regulator, maximum power 12 V - 40 A

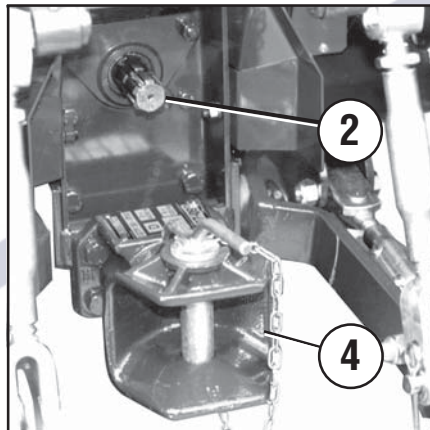

Fig. 9

- Starter motor with electro-magnet engagement, power 12 V - 1.4 kW.

2.23 ILLUMINATION AND SIGNALLING DEVICES

- Asymmetric headlights with 40/45 W bulbs.
- Front sidelights with 5 W bulbs.
- Turn indicator lights with 21 W bulbs.
- 5/21 W bulb for sidelights and stop light.
- 21 W bulb for direction indicators.
- Central red reflector.
- Number plate light with 5 W bulb.
- Rear work pivotable headlight with 50 W bulb.

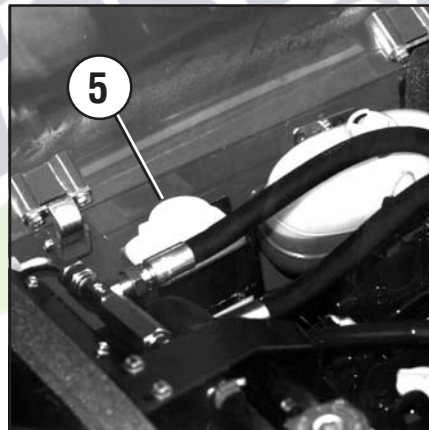

Fig. 10

2.24 INSTRUMENTS AND ACCESSORIES

- Control panel including start controls, lights, horn, indicator lights, time-revolution meter, digital speedometer, water temperature indicator, emergency light blinker, protection valve box, with 7,5 A, 10 A, 15 A and 25 A fuses.
- Rear 7-way power outlet.
- Thermostarter.
- Safety start device (with clutch disengaged).

2.25 HYDRAULIC SYSTEM

Gear pump operated directly by the engine.
Induction from front box.

2.26 WINDSCREEN WASHING LIQUID TANK

Located in the engine compartment (5 Fig. 10).

2.27 HYDRAULIC COUPLINGS (Optional)

On request, the machine can be equipped with single- or double-acting hydraulic couplings for application of special implements.

2.28 AIR FILTER

Located in the engine compartment, the air filter consists of a filter cartridge (1 Fig. 11).

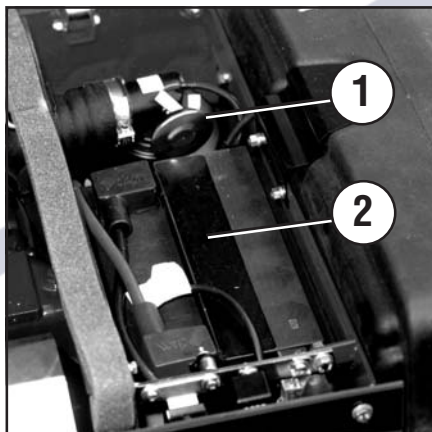

Fig. 11

2.29 WATER RADIATOR

The radiator assembly is made up of two radiant masses:

- Radiant mass A (Fig. 12) for the cooling of the oil in the hydrostatic circuit.
- Radiant mass B (Fig. 12) for the cooling of the water in the engine cooling circuit.

The water and antifreeze is added through the filler (3 Fig. 13); bleed the radiator through the air valve (4 Fig. 13).

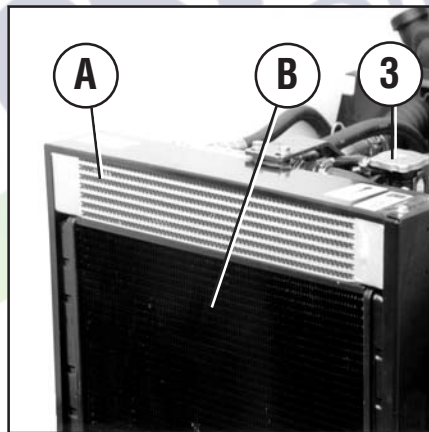

Fig. 12

2.30 EXHAUST PIPE PROTECTION

The Fiberglass protection (6 Fig. 14) protects the engine hood from possible overheating caused by the engine exhaust pipe.

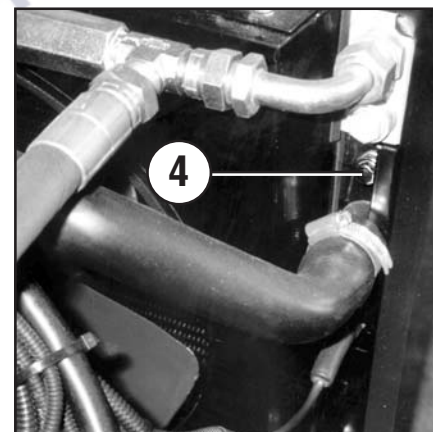

Fig. 13

2.31 HOOD OPENING

Hood release lever (5 Fig.14).
Hood support (7 Fig. 14).

2.32 FUEL TANK

Made of plastic and located in back of engine (9 Fig. 14), capacity of 35 lt. Filler cap (8 Fig. 14).

2.33 BATTERY

Positioned inside the engine compartment, see details (2 Fig. 11).

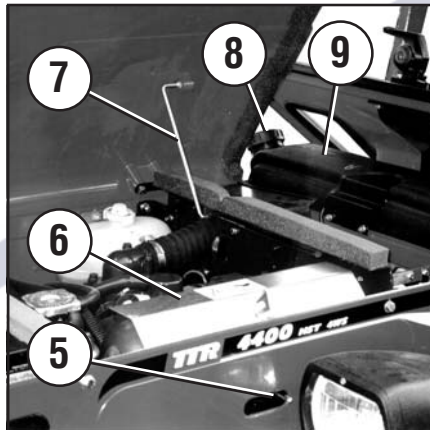

Fig. 14

2.34 SOUND LEVEL

The sound levels perceived by the driver, measured in conformity with EEC directive 77/311, annex II (machine not loaded, running at 7.25 km/h) are the following:

Tigretrac TTR 4400:

With arch dB (A) 90
Frame dB (A) 88
Cab dB (A) 85

Tigretrac TTR 4400 4WS:

Frame dB (A) 88
Cab dB (A) 85

The ambient sound levels, measured in conformity with EEC directive 74/151/VI, are the following:

TTR 4400 at a standstill..... dB (A) 82
TTR 4400 4WS at a standstill... dB (A) 82
TTR 4400 moving dB (A) 81
TTR 4400 4WS moving dB (A) 82



ATTENTION. When using the machine for a long period it is advisable to use hearing protection equipment, such as ear muffs.



WARNING. Cab doors and windows must be kept closed while vehicles are being driven.

3.1 TRANSPORTATION AND HAULAGE



WARNING. Load, unload and move the machine with maximum care, observing the instructions that follow:

- Do not lift the machine with cranes, forklifts, etc.
- Move machine by driving it from driver's seat.
- In case machines need to be towed, use special fittings applied only on hitches (Fig. 7 - 8 - 9).
- In case machine needs to be towed, make sure wheels are aligned and not ready for steering; do not use cables but special towing bars.
- When loaded onto transportation vehicles, the machine must be securely braked and anchored with special lockings.
- During unloading from the transportation vehicle, truck or trailer, use loading ramps of suitable capacity according to the weight and gauge of the machine.

We also wish to remind you that when the engine is switched off, the hydrodrive system is not activated therefore the steering wheel must be moved with greater force.

3.2 MACHINE STANDARD EQUIPMENT

The machine is supplied complete with:

- Warranty certificate.
- Use and maintenance manual.
- Engine use and maintenance manual.
- Tools for regular maintenance of machine.

4.1 GENERAL SAFETY REGULATIONS

The safety of the operator is one of the main concerns of designers and manufacturers of a new machine. In the engineering of a new machine one tries to foresee all the possible hazardous situations and consequently adopt the proper safety measures. Accidents due to improper and unsafe use of the different farming implements are however numerous.

We therefore recommend that you read this manual carefully, particularly the safety regulations, paying close attention to the operations that are particularly hazardous.

Keep this manual always at hand on the machine.

Antonio Carraro spa declines all responsibility in case of non-observance of the safety measures and accident prevention rules described herein.

Furthermore, it declines all responsibility caused by the unsafe use of the machine or non-authorized tampering.



Pay attention to the triangular danger sign shown in this manual. This illustration precedes and warns of immediate hazards.

There are three types of hazard signs in this manual:

- **DANGER** signs alert personnel that if the operations described are not carried out properly, they can **cause injuries**, death or long term health problems.
- **WARNING** signs alert personnel that if the operations described are not carried out properly, they can **cause injuries**, death or long term health problems.
- **CAUTION** signs alert personnel that if the operations described are not carried out properly, they **can cause damage** to the machine or attached implements.

Make sure to pay particular attention to the danger signs of the decals on the machine. Do not remove them or make them illegible. Clean them when dirty and replace them immediately when detached or damaged. Strictly observe all the prevention rules recommended and described in this manual.



WARNING. In some illustrations found in this manual, panels or guards have been removed to show items more clearly. Never use the machine without these panels or guards.

4.1.1 CLOTHING

Avoid wearing loose clothing. It could get entangled in the movable parts of the machine or implement, causing injuries to the operator. Vice versa, suitable clothing and safety shoes may be required when using certain implements such as manure-spreader, atomizer, etc.



WARNING. Please comply with the instructions issued by the manufacturers of the implements and of the chemical products used.

4.1.2 DRIVER'S SEAT

- Do not drive or allow the machine to be driven by people without experience a driver's license or with health problems.
- Do not carry passengers on the machine.
- In case the machine overturns, do not attempt to abandon the machine. Hold on firmly to the steering wheel, keep feet solidly on the floor and your back against the seat and body weight on the side op-

- posit the overturning direction.
- Before starting work, familiarize with the different control devices and their functions.
- Keep windows and rear view mirrors clean, make sure visibility is good.
- If machine is provided with seat belts, we recommend that you fasten them after having adjusted them to proper length.
- When work has been completed, remove the ignition key from the control panel, and position the special guard over the switch.

4.1.3 ENVIRONMENT, POLLUTION

- Do not keep engine running in closed premises, exhaust gases are harmful and may cause death.
- Do not throw away labels and instructions of chemical products used in farming: in case fuels, insecticides, chemical substances, etc. are swallowed, contact a hospital emergency ward immediately, providing the necessary labels or instructions.
- Observe local standards and regulations regarding sound pollution.
- Replace engine exhaust pipe when worn out or when noise produced is higher than the allowed noise level. Use genuine spare parts.

- Disposal of lubricant or disposal of the machine must be performed according to the regulations in force in the country in which the machine is used.
- Do not throw batteries in dumps. They must be handed in to authorized disposal companies.

4.1.4 COUPLING OF IMPLEMENTS

- The attachment of a supplementary implement to the machine, involves a different weight distribution on the axles. We therefore advise not to exceed the maximum load of the machine.
- Attach only implements in accordance with the power of the machine and in compliance with the standards they are subject to.
- Before attaching, detaching or using an implement, consult relative instructions manuals. In any case, before detaching, connecting or adjusting an implement connected to the power take-off, it is necessary to lower the implement on the ground, stop the engine, engage the parking brake and if necessary place a chock underneath the wheel.
- Implements must be provided with proper indicators and protections.
- It is important to bear in mind that the roadholding and the steering and brak-

ing capacity can be drastically influenced by the attachment of a driven or towed implement.

- Pay particular attention, when taking a bend, to the centrifugal force exerted in position different from the gravity centre with or without driven implements.
- Before engaging the power take-off, make sure of the number of r.p.m.'s required by the implement.
- Keep away from a working machine or from working implements.
- Before leaving the machine always lower the implement attached to the power lift, disengage the PTO, turn off the engine, put on the parking brake and remove the ignition key from the instrument panel. On slopes, engage the slow gear; for greater safety use also a wheel chock.
- When engine is running, never place yourself between the machine and the implement, without having put on the parking brake and having used a wheel chock.
- Before hooking or unhooking the implement from the third hitch coupling, lock the power lift control lever.
- Pay particular attention when standing near an attached implement, since due to inertia, it could still be running even after having switched off the engine.

- Be very careful when mounting the implements, strictly follow relative instructions.
- The category of the coupling pins of the implement must correspond to that of the power lift coupling.
- Pay particular attention when working near the power lift arms, this is a very hazardous area.
- Remember that when the engine is running, implements can be running too and some of them can be extremely hazardous.
- Never clean, lubricate, repair or adjust the machine or the tools attached to it while the machine is running. Always turn the engine off first and stop the machine.

4.1.5 DRIVING ON PUBLIC ROADS

When travelling on roads, always observe the rules of the road in force in the country in which the machine is used.

4.1.6 SAFETY DEVICES

- Before starting the machine check that all the guards, safety shields, and safety devices have been installed correctly on the machine. In particular, check the anti-tilting device and the parts connected to the PTO.

- Do not modify, tamper with or avoid the assembly of the safety devices.

4.1.7 DECALS

- Labels with wording, applied on the machine, provide instructions and warning which are easily identified.
- Decals regarding safety must always be clearly visible; they must be kept clean and replaced when not legible. See configuration and position on paragraph 5.1.1.

4.1.8 POWER TAKE-OFF

- The PTO must be engaged only to actuate the driven implements, therefore when the machine is used for other purposes, the control lever must be in neutral position.
- Always disengage the PTO when the angle of the universal shaft is too wide and when it is not used.

4.1.9 UNIVERSAL SHAFT

- Use only universal shafts recommended by the manufacturer of the implements.
- Often check the protection of the universal shaft, it must always be in perfect working condition.
- Do not use the PTO protection as bearing surface.
- The installation and the disassembly of the universal shaft must be carried out when engine is turned off and machine stopped.
- Carefully check mounting and protections of the universal shaft.
- Lock the rotation of the universal shaft protection using the chains.
- Do not take sharp bends with the PTO under load; this will avoid damages to the universal shaft.
- After having disassembled the universal shaft, put the protection back onto the PTO shaft.

4.1.10 SAFE USE

- Do not proceed to use the machine unless you have acquired a perfect understanding of the position and operation of all the controls.
- When using the machine, always remember that caution is always necessary for preventing accidents.
- Avoid touching parts in motion.
- If you believe that machine can be unsafe in some way, get in touch with qualified personnel.
- Never leave the machine running or with ignition key inserted when not in driving position.
- The instructions manual must be kept throughout the life of the machine.
- Be extremely careful when using the machine on rough, wet or slippery terrain. Use the machine on safe grounds.
- Before manoeuvring the machine, check that there is enough space, that the way is clear and that there are no children or animals in the field of action; signal presence of the machine using the buzzer and the signal light. Bear in mind that the overall dimensions of the machine vary according to the attached implements.
- When visibility range is reduced, use the low gear and ask other people on the ground for help.

- Before starting the engine make sure that the gear and the PTO levers are in neutral, even if the machine is equipped with safety devices for starting.
- Keep in mind that, if the protective structure is lowered, the driver's seat is not protected in the event of roll-over.
- Let the engine idle for several minutes before starting work.
- We recommend never to exceed one half maximum engine power during the first 50 working hours.
- Never touch exhaust pipe when the engine is overheated or running.
- Suitably select the operating speed so that the engine will not be overloaded.
- Never leave machine with engine running unattended.
- Never travel downhill with the clutch disengaged or with the gear lever in neutral.
- Always engage the clutch gradually, especially during operation.
- Never jump on or off the machine when in motion.
- Use the differential locking device only with the slow gears; in any case, before locking the differentials, let the engine revolutions slow down. Do not lock the differentials on or near bends.

- **Disconnect the four-wheel drive when travelling on the road.**

4.1.11 USE ON SLOPES AND UNEVEN GROUNDS

There may be the possibility that the machine overturns when working on slopes and particularly uneven grounds, therefore:

- operate machine at minimum speed.
- Avoid sharp and sudden steering while going up a slope or steep slopes.
- Gear must always be engaged to allow engine braking while going downhill.
- Be extremely careful when using machine with four-wheel drive on uneven grounds and steep slopes.
- Engage low gear and four-wheel drive when going down steep slopes.

4.1.12 MAINTENANCE

- Machine maintenance and adjustments should always be carried out with engine off, parking brake on and attached implements solidly on the ground.
- Observe the conformity of the recommended oils.
- The spare parts must meet manufacturer's requirements. Use only genuine spare parts.

- Do not perform repairs if not duly authorized and qualified.
- Periodically check the pressure and wear of the tires.
- Constantly check that there are no loose parts, especially pipe connections.
- Check parts that produce noise or vibrations that, if neglected, can cause disorders and faulty operation.
- Report oil, fuel and battery acid leaks immediately.
- Do not tamper with machine engine and gearbox to achieve performances differing from the ones provided by the manufacturer.
- Check and adjust the brakes periodically, especially when working with heavy loads.
- Never touch the fuel tank or supply tubes when the engine is overheated or running.
- Never touch radiator when motor is running; do not approach revolving fan.
- Always disconnect the earth cable from the battery when handling any part of the electrical system.
- Before touching the hydraulic system, check that the same is not under pressure. In any case, always use gloves, goggles and any other safety means which will prevent you from being hurt by sudden oil leaks. Do not touch hydraulic system when hydraulic cylinders, even with engine off, keep any part of the machine elevated.
- Always use wheels and tires recommended by the manufacturer.
- Tires must be inflated at suitable pressure; replaced when worn out, cracked or cut.
- Overheated parts of the machine can cause fire, burns, deformations, explosions, etc. when near certain solids, liquids or gasses.
- Acids contained in the battery are particularly hazardous. We recommend the use of gloves and face protection to avoid injuries.

4.1.13 REFUELLING

- Always fill the fuel tank in the open air. Do not smoke during this operation. Try not to spill fuel (especially petrol) on the machine or nearby. If this happens, dry the fuel up and move the machine away before starting up the engine.
- Store fuels and lubricants in a safe place since they can be flammable, explosive, toxic or corrosive. They must be stored in their original packaging, well sealed and away from unauthorised person's reach.
- Bear in mind that tanks, containers, pipes and accessories for flammable or explosive substances are subject to breaking and wear (even when empty).
- Do not smoke or light fire or sparks near fuel or tanks and containers even when empty.

5.1 MACHINE DESCRIPTION

(Fig. 15)

- 1 - Engine hood
- 2 - Front turn indicator lights
- 3 - Front headlights
- 4 - Fuel filler cap
- 5 - Front windshield wiper
- 6 - Rear view mirrors
- 7 - Rear window wiper
- 8 - Rear lights
- 9 - Rear PTO
- 10 - Rear power lift
- 11 - Rear tow hook
- 12 - Rear wheels
- 13 - Front wheels
- 14 - Front power lift
- 15 - Front PTO
- 16 - Front tow hook



Fig. 15

5.1.1 DECALS



Conformity mark in accordance with the **EEC DIRECTIVE 89/336** and subsequent amendments. Harmonised standards applied: **Project ISO/CD 14892** relevant to agricultural and forestry machinery. This indicates that the machine is in conformity with the essential requirements in point of electromagnetic compatibility.



Caution: revolving fan. Do not put hands near revolving blades. The engine hood must be opened only when engine is stopped.

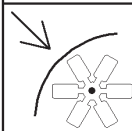

Danger! Keep away from universal shaft. Keep clear of machine moving members. Put protection back into place after use of PTO.



This machine must be used only by skilled personnel. For safer use, read and carefully observe the instructions contained in the instructions manual. Before maintenance, stop the machine, put on the parking brake and consult the instructions manual.



Danger! Keep away from universal shaft. Keep clear of machine moving members. Put protection back into place after use of PTO.

Fig. 16

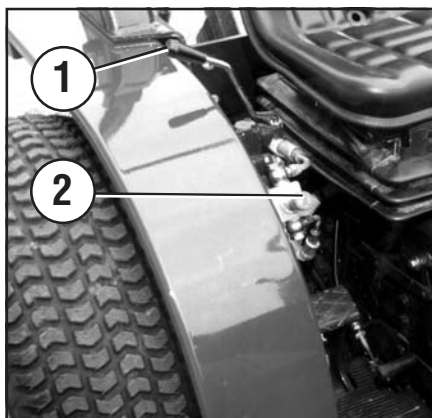

Fig. 17

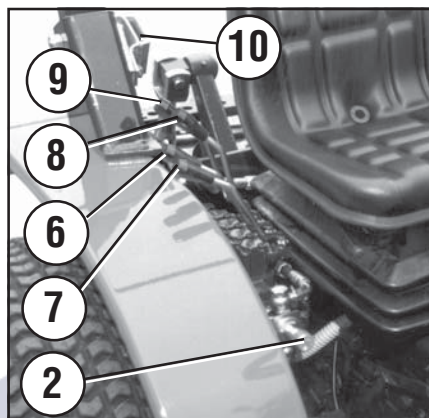

Fig. 19

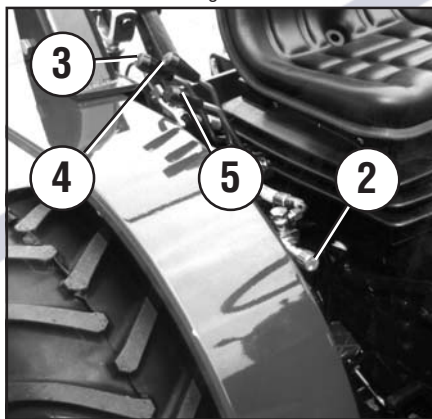

Fig. 18

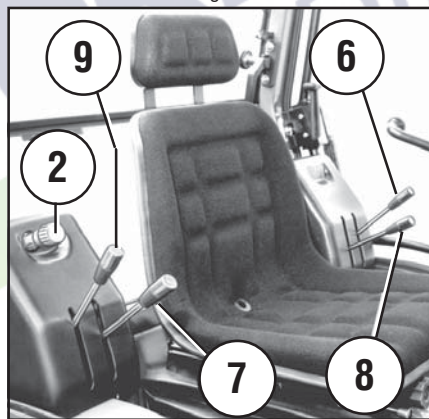

Fig. 20

5.1.2 CONTROLS AND INSTRUMENTS

1 - Rear elevator control lever.



2 - Flow regulator.

It determines the elevator's speed.

3 - Control lever for single-acting hydraulic couplings.

4 - Control lever for double-acting hydraulic couplings.

5 - Rear elevator control lever.

6 - Control lever for single-acting hydraulic couplings.

7 - a) Control lever for single-acting hydraulic couplings
b) Front elevator control lever (optional on request).

8 - Control lever for double-acting hydraulic couplings (front and rear combined).

9 - Rear elevator control lever.



5. MACHINE DESCRIPTION

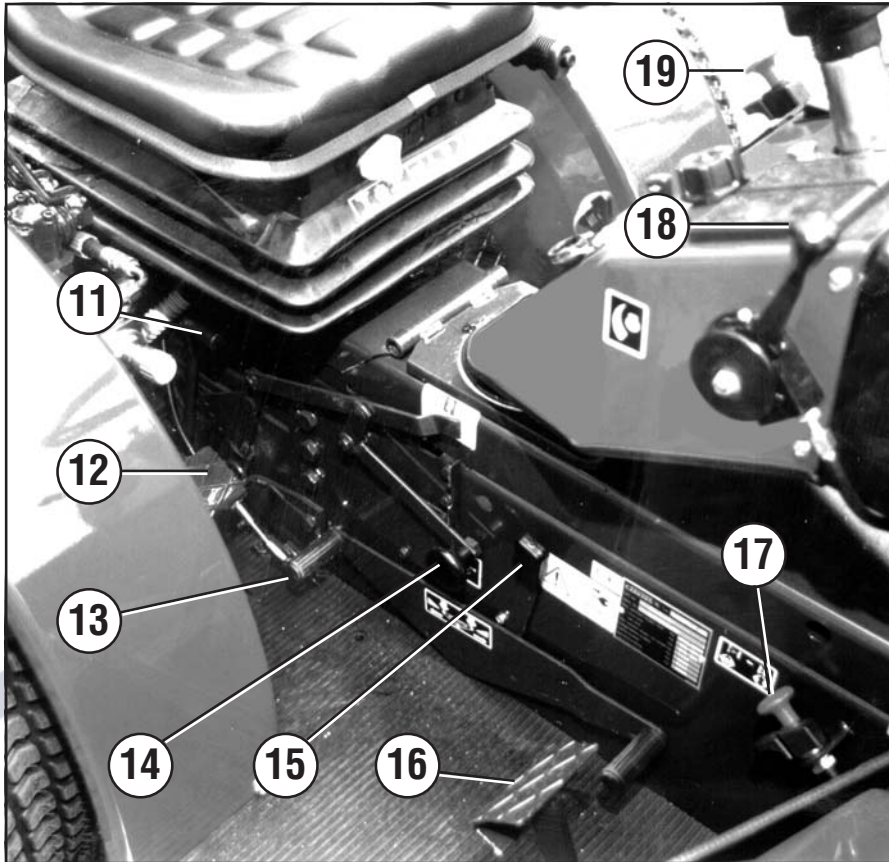

Fig. 21

10- Trailer brake support.

11- Rear differential locking device



12- Clutch pedal.

To be used:

- when changing gear;
- to actuate the PTO.

13- Hydrostatic gearshift rocker arm pedal.



It allows a continuous forward speed variation in proportion to the displacement of the pedal. By stepping on the front of the pedal the machine moves forward; by stepping on the rear of the pedal the machine moves backward. Maximum speed is achieved by pressing the pedal to end of stroke. If the pedal is released the machine stops.

14 - Three-speed selector drive lever
slow-regular-fast.



15- «SPEED-FIX» lever.



16- Brake pedal.

17- Front differential locking knob.

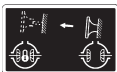

18- Accelerator control lever.



19- Drive disengagement knob.



20- Rear power take-off control lever.

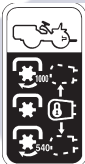

21- Clutch pedal.

22- Hydrostatic gearshift rocker arm pedal.

23- Brake pedal.

24- Parking and emergency brake lever.



25 - Starting switch.



Used to activate the electrical circuits of the machine. The key can be turned to the following positions:

- P Lights on when parked;
- 0 Disengagement of all circuits;
- 1 Activation of all the circuits, except for the pre-heater circuit;

- 2 activation of the pre-heater circuit;

- 3 engine start.



starting switch

26 - Lights and buzzer switch.

With this key in position 1 it is possible to turn the lights on in order. The buzzer is sounded by applying a slight pressure to the same lights switch.

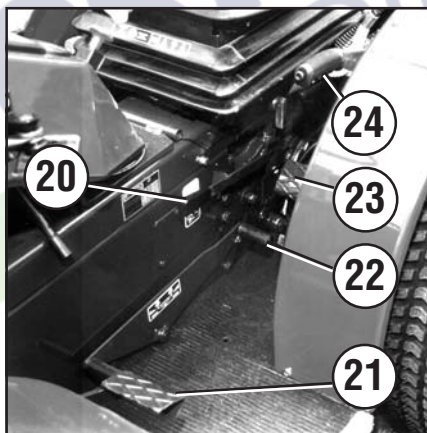

Fig. 22



Fig. 23

5.1.3 CONTROL PANEL

1 - Time and r.p.m. meter.

Indicates the number of motor revolutions, the power take-off and the number of operating hours of the machine.

2 - Buzzer.

Audible signalling device.

3 - Digital speedometer.

4 - Protection fuse box.

For their specific function, see paragraph 7.10.3.

5 - Lamp alarm switch.

Activates the emergency lights.

6 - Work lights switch.

7 - Steering selector control switch.

8 - Clogged oil filter indicator light.

When this indicator lights up a buzzer will also sound.

9 - High water temperature indicator light.

When this indicator lights up a buzzer will also sound; the engine should run at minimum speed and if the signal persists check the cooling system.

10 - Lights and buzzer switch.

11 - Front PTO control switch (optional).

When the switch is pressed, after shifting down the safety lever, the front PTO is engaged and the incorporated indicator light comes on.

12 - Starting switch.

13 - Clogged air filter indicator light.

(The lighting of the indicator light is also signalled by a buzzer) if it comes on proceed as described in paragraph 7.2.1 "Air filter".

14 - Turn indicator switch.

With the ignition key inserted and activating all the circuits, by pressing the switch lever downward the lights will start flashing.

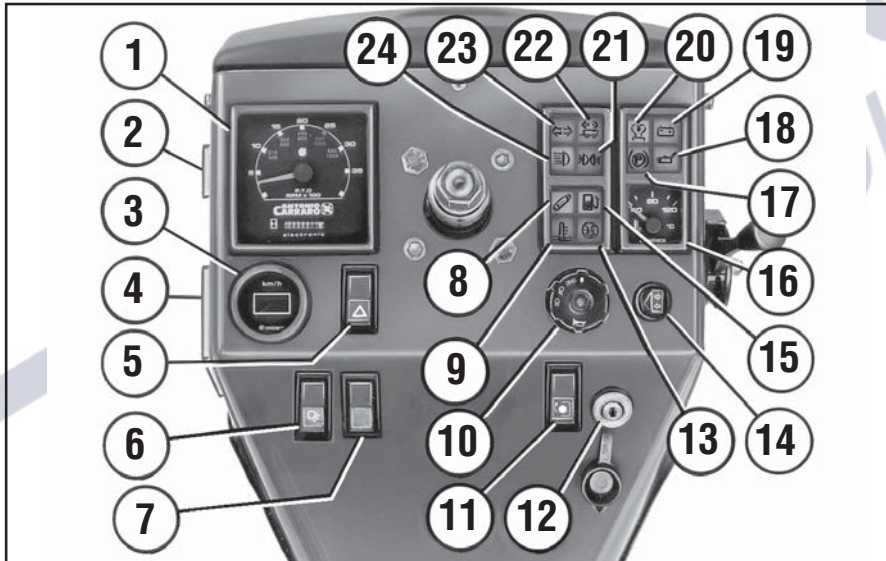

Fig. 24

15 - Fuel gauge.

16 - Water temperature gauge.

17 - Parking brake indicator light.

18 - Oil pressure warning light (red).

Should this indicator switch on when the engine is at high r.p.m., immediately turn off the engine and check the oil level in the sump and if necessary call a qualified technician. A buzzer will also sound when indicator lights up.

19 - Low battery indicator light (red).

In case of persistent starting, even with engine at high r.p.m., call a qualified technician for an accurate check of the regulator and the alternator.

20 - Pre-heater indicator light.

21 - Warning light for parking and lower beam lights.

22 - Warning light for trailer turn indicators.

23 - Warning light for turn indicators.

24 - Driving beams indicator light.

5.1.4 SEAT

The drive seat can be adjusted as follows:

MOD. MT GT 600 (Fig. 25)

- 1 - Longitudinally. To adjust distance from controls, move the lever (A) sideways.
- 2 - Vertically. To lift the seat, rotate knob (B) counterclockwise and clockwise to lower it.
- 3 - To adjust springiness in compliance with the weight of the driver, operate on lever (C).

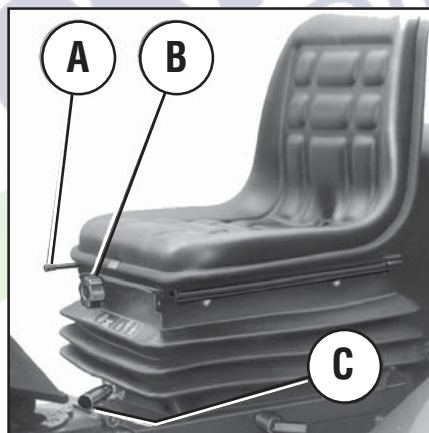

Fig. 25

BOSTROM seat (Optional) (Fig. 26)

- 1 - Longitudinally. To adjust distance from controls, move the lever (D) sideways;
- 2 - Vertically. To lift the seat, rotate knob (E) counterclockwise and clockwise to lower it;
- 3 - To adjust the sensitivity of the springing system according to the weight of the driver, operate lever (G) repeatedly as indicated, and check to see that the pointer (F) moves in the right direction.

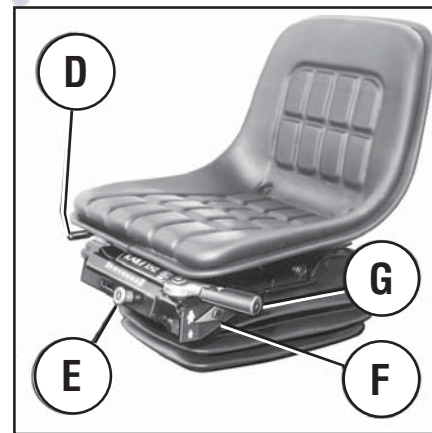

Fig. 26

5.1.5 CAB INSTRUMENTS

(Fig. 27 - 28 - 29)

1 - Temperature adjustment knob.

2 - Air recirculation vents.

- when the vents are closed all the way the air is sucked from the outside and filtered through a filter located under the roof.
- when the vents are partially or completely open the air is recirculated inside the cab.

3 - Rotating light switch.

4 - Adjustable air vents.

5 - Cab light with built-in switch.



6 - Front wiper/washer switch. By pressing further the windshield washer is activated.

7 - Rear wiper/washer switch. By pressing further the windshield washer is activated.

8 - Electric fan switch 3 speed.

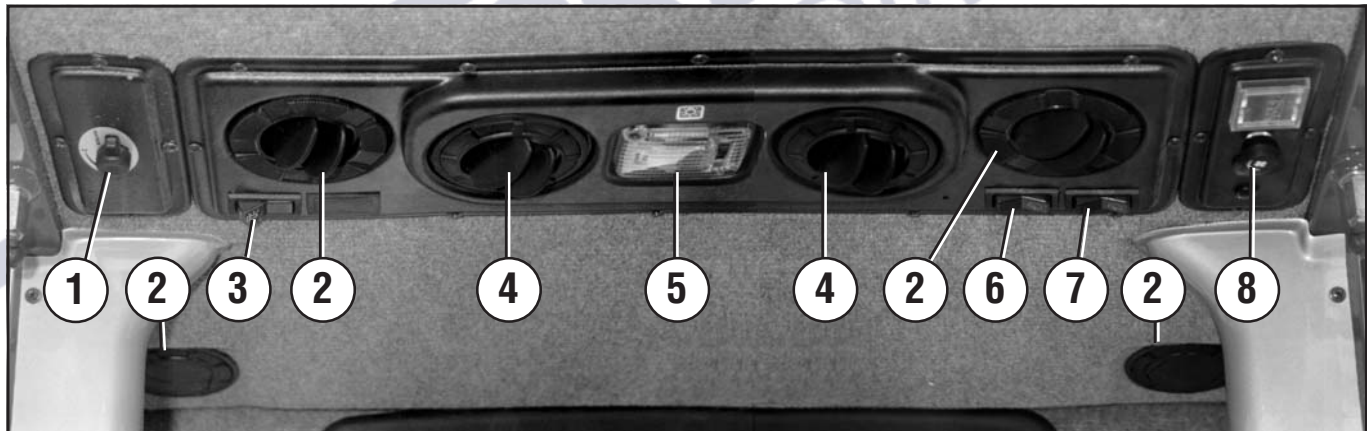

Fig. 27

9- Adjustable air vents.

They are connected by special ducts that convey the air and distribute it also on the operator's feet, ensuring proper temperature diffusion.

10- Windshield wiper control lever.



11- Rotating lamp switch.

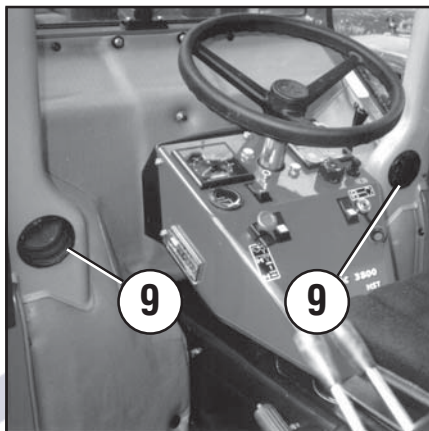

Fig. 28

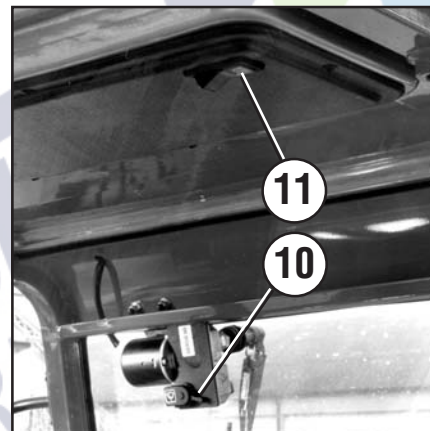

Fig. 29

6.1 GENERAL RULES

A good and cautious operator must observe fundamental and simple behaviour rules in order to guarantee his safety, that of others, and protect the machine from possible damages.

For this purpose, routine operations must be performed with maximum care, do not proceed to use the machine unless you have acquired a perfect understanding of the position and operation of all the controls.

If the operator is authorized and has the skill and ability, he can perform maintenance operations following the instructions given in this manual.

Complex maintenance must be submitted to qualified personnel and not chargeable to the operator, who is however responsible for maintaining of the machine in good running condition.

The maintenance performed by the operator will determine the wear condition of the machine in the long term. For this reason, the maintenance must be the most suitable possible to avoid breakdown of the most stressed members so as to keep up the value of the machine.

It is therefore expedient that the operator takes good care of the machine and immediately reports faulty functioning and inconveniences observed. By doing so, the operator highly contributes to the maximum efficiency of the machine.

Useful advice:

- 1 - Familiarize with the machine so as to know all the details and to report any faulty functioning that, if neglected, can cause disorders and faulty operation.
- 2 - Constantly check that there are no loose parts, especially pipe connections.
- 3 - Periodically check the pressure and wear of the tires.
- 4 - Check parts that produce noise or vibrations that, if neglected, can cause disorders and faulty operation.
- 5 - Report oil, fuel and battery acid leaks immediately.
- 6 - Do not perform repairs if not duly authorized and qualified.

The operator, constantly using the machine has greater opportunities to observe and report faulty operation preventing damages and contributing in this way to improve the efficiency of the machine.

6.2 BEFORE USE



WARNING. Before starting the machine check:

- the oil level in the engine (see separate manual regarding engine);
- the level of liquid in the radiator (see paragraph 7.2.2);

- the level of fuel in the tank.

Then engage the parking brake: move the gearshift lever to the idle position and disengage the power takeoff.



WARNING. Before beginning start-up and stopping operations, always check that the hydrostatic gear pedal is in the neutral (mid-way) position and that the «SPEED-FIX» device is disconnected in the FREE position. The «SPEED-FIX» device in «LOCKED» position allows operation at constant speed, since it locks the hydrostatic gear-shift pedal at the position wanted; it must only be used when the vehicle is working. Before driving into an open road, always disconnect this device by bringing the lever to the «FREE» position.

6.3 USE OF MACHINE

6.3.1 STARTING ENGINE

To start the engine, proceed as follows:

- Make sure that the gearshift lever and the power takeoff engagement lever are in the idle position;
- press the clutch pedal all the way down to close the ignition enable switch.
- move the accelerator lever to mid-stroke position.

- insert the key in the starter and turn it to position "1". At this point only the «insufficient oil pressure» (18 Fig. 24), «insufficient battery recharge» (19 Fig. 24) indicator lights should come on.
- turn the key to position "2" while pressing it; the "preheater on" indicator light should come on (20 Fig. 24);
- Wait until the pre-heater indicator light goes out and then turn the key to position "3" until the engine starts up.
- Let go the key (it will return to position "1") and gradually bring the accelerator control lever to the initial minimum position. If the engine does not start up right away, return to position "2" and repeat the operation after 10 seconds.

6.3.2 STARTING ENGINE AT LOW TEMPERATURES



CAUTION. When the ambient temperature is below or near 0°C, check and if necessary add recommended antifreeze liquid in the cooling circuit. We recommend adding a diesel additive for easier starting; follow the product manufacturer's instructions. To start engine at low temperatures, proceed as for normal start.

6.3.3 TURNING OFF THE ENGINE

To stop engine, proceed as follows:

- bring the accelerator control lever to minimum speed;
- engage parking brake;
- turn the key to the "0" position;
- remove the ignition key and position the guard over the switch.



power.

WARNING. During the first 50 working hours, we recommend not to exceed half the motor maximum

6.3.4 STARTING THE MACHINE



WARNING. Before starting the machine, make sure there are no people, children or animals in the field of action.

- After having started the engine;
- bring the selector lever to the gear position required (slow - regular - fast, 2 Fig. 30);
- while slightly pressing the rocker arm pedal to facilitate the engagement of the gear;
- release the parking brake and gradually engage the clutch;
- push the hydrostatic gear pedal (1 Fig. 30 - 4 Fig. 31) slowly in the operating direction desired accelerating the engine as necessary;
- if necessary, the pedal can be locked with lever (3 Fig. 30) in order to maintain a constant speed.

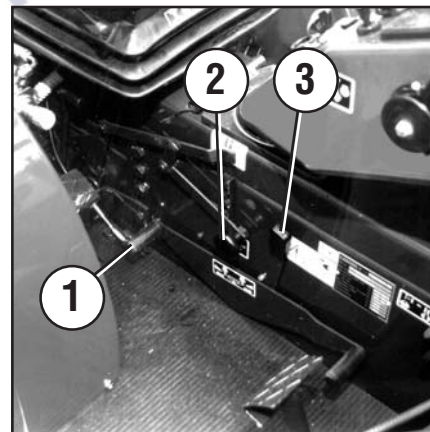

Fig. 30

6.3.5 GEARSHIFT

The drive has a mechanical gearshift with 3 speed ranges; with lever that selects three ratios: slow, normal, fast.

It features three forward and 3 reverse speeds.

The speed change gear control can be locked in any position by the "SPEED-FIX" device.

6.3.6 WHILE RUNNING



WARNING. Do not leave foot on the clutch pedal.

Do not go down slopes with neutral gear. Drive carefully.

6.3.7 STOPPING THE MACHINE

- reduce engine revolutions, disengage;
- the pedal stop lever (3 Fig.30) and bring the gear pedal to mid-stroke position (stop);
- disengage the clutch and bring the selector lever to the neutral position;
- press the brake pedal;
- engage the parking brake.

If the vehicle is on a sloping ground, engage the slow gear and for further safety a wheel chock can also be used.

6.3.8 POWER TAKE-OFF

The machine can be equipped with two PTO's: a front electro-hydraulically operated power take-off (optional), which can operate at an independent speed of 1000 r.p.m. with engine 2500 r.p.m., clockwise rotation. A rear PTO which operates at an independent speed (540 and 1000 r.p.m.).



NOTE. By means of the hydrostatic gear pedal it is possible to stop or reduce the gear speed, at the same time keeping the number of PTO revolutions constant.



WARNING. The power take-offs must be engaged only to actuate implements, therefore for all other uses of the machine, the control levers must be in neutral position.



DANGER. When the engine is running, do not remove protections or stand near universal shafts. Make sure there are no people, children or animals in the field of action.



DANGER. Before operating on the implements actuated by the machine, disconnect the power take-off, stop the machine, set the park-

ing brake, lower the implement to the ground and remove the ignition key.

6.3.8.1 FRONT POWER TAKE-OFF (Optional)

To engage the front electro-hydraulically operated power take-off (Fig. 6) press the PTO switch (A Fig. 32). The incorporated telltale light comes on and an impulse is sent to an electric valve which enables oil delivery to the front PTO. It can be engaged even while the machine is loaded, since it is independent of the gearshift and rear PTO. To disengage the PTO just press

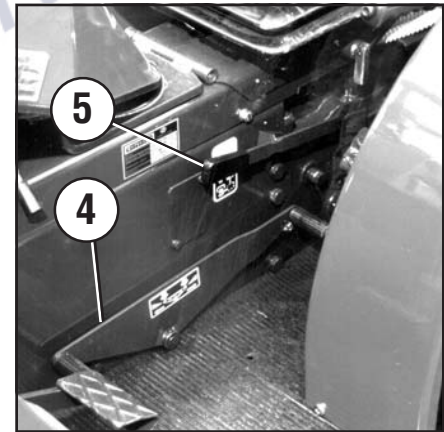

Fig. 31

the corresponding switch: the telltale light must go off.

6.3.8.2 REAR POWER TAKE-OFF (Independent)

It is driven directly by the engine and is totally independent of the gearshift; it can therefore be used either while the machine is stopped or running. To start power takeoff rotation, disengage the clutch and move lever (5 Fig. 31) to position 540 or 1000.



Note. By means of the hydrostatic gear pedal it is possible to stop or reduce the gear speed at the

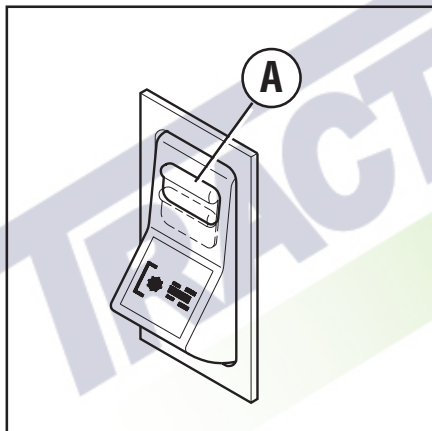

Fig. 32

same time keeping the number of PTO turns constant.

6.3.9 WHEEL DRIVE

The wheel drive gives the machine better grip which is particularly important when working on uneven ground or under difficult conditions. For jobs that do not require such a strong traction force, for example when working on lawns or grass surfaces, the wheel drive can be disengaged allowing better machine manoeuvrability and operation.

To disengage, pull the knob (19 Fig. 21) all the way out with the engine decelerated; in order to engage, just unlock the knob via its lever; the knob will return to its normal position (wheel drive engaged).

6.3.10 LOCKING THE DIFFERENTIALS



DANGER. Only use the differential lock during straight-line travel. Never take bends with the differentials locked.

The machine is equipped with a differential locking device on the rear axle and on the front axle. This device must be used only when wheels skid or in case of lack of adherence to the ground.

To lock the differentials, reduce engine rpm and perform the following operations:

- move the rear control lever (11 Fig. 21) outward to end of travel;
- pull the front control knob (17 Fig. 21) all the way.

POWER TAKE-OFF TABLE

PTO	TTR 4400		TTR 4400 4WS	
Independent front PTO r.p.m.	1000 with engine at 2500 r.p.m.		1000 with engine at 2500 r.p.m.	
Independent rear PTO r.p.m.	540 with engine at 2500 r.p.m.	1000 with engine at 2460 r.p.m.	540 with engine at 2500 r.p.m.	1000 with engine at 2460 r.p.m.

To disengage, shift the special lever in the knob 17 (front) and move back inward the lever 11 (rear).

6.3.11 HYDRAULIC STEERING (Tigretrac TTR 4400 4WS)

On TTR 4400 4WS both axles have steering wheels.

By operating the three-position steering selector control switch, the following functions are activated:



Position 1
Two front steering wheels.
Primary configuration, enabled for circulation on public roads, bottom end of switch pressed with incorporated telltale light on.



If the switch is in position 1, when the detection pin passes the half-way steering point, the proximity sensor located on the rear axle, through the electric valve of the hydraulic distributor, automatically locks the rear wheels in line with the longitudinal axis, and steering starts with the two-steering wheel configuration.



Position 2
Four steering wheels, intermediate switch position.



If the switch is set to position 2 the rear proximity sensor is deactivated and the front one is activated. When the detection pin passes the half-way steering point of the front axle, the electric valve of the hydraulic distributor is activated and steering starts with the four-steering wheel configuration.



Position 3
Amble.
Top end of switch pressed.



If the switch is set to position 3, the ambling function is activated. To activate this function, if the switch was previously in position 2, the required angle of the rear steering must be set (we recommend you do not exceed 10°). When the switch is set to position 3, the power supply to the electric valve of the hydraulic distributor is interrupted and the rear wheels are locked in the desired posi-

tion. The front wheels can then be steered with the amble function.



WARNING. Be careful when switching from position 3 to position 1. First align the front wheels and then press the switch to position 1, and move the steering wheel until the rear wheels are locked.



WARNING. Be careful every time you start the machine: before you begin work, set the steering selector control switch to position 1 and align the rear wheels.
After you have done this you can switch to positions 2 and 3.

6.3.11.1 SAFETY SYSTEM

This system allows the machine to continue to operate even in the event of electrical malfunctions or distributor jam. If such malfunctions should occur use the emergency button located on the hydraulic distributor on the back of the machine (Fig. 33). When you press the emergency button, you can carry out a visual alignment of the wheels; release the button to lock the wheels in the set position. This way you can use the machine with the driving system as if it was in position 1.

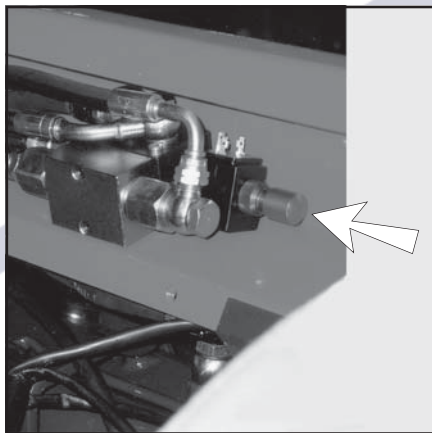

Fig. 33

Remember to have the steering system checked out and restored to normal as soon as possible.



WARNING. The four steering wheel operation cannot be used while on public roads. Before accessing a public road set the switch to position 1. The incorporated telltale light must be on; this is the correct configuration for public road circulation.

6.3.12 HYDRAULIC POWER LIFT

The machine is equipped as standard with a rear elevator; a front elevator for hitching farming implements is also available on request.

Both hydraulic elevators are driven by the same hydrodrive circuit which has a «LOAD SENSING» valve.

Features:

- Gear pump driven directly by the engine: 11,3 cm³/rev.
- Nominal capacity with 3000 r.p.m. motor: 33 dm³/min.
- Oil suction from the front transmission case.
- Operated via two, single-action, hydraulic jacks controlled by a regular distributor; double-action hydraulic jacks can be

supplied on request for the rear hydraulic elevator.

- Limiting valve setting: 130 - 140 kg/cm².

Operation

The normal rear and front hydraulic elevators are operated by means of distributor lever following this order:

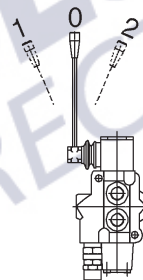

- pos.1 (fixed) hydraulic elevator lowers;
- pos. 0 (fixed) hydraulic elevator stops lowering;
- pos. 2 (with spring recovery) hydraulic elevator rises.

The double-action hydraulic elevator is operated by means of distributor lever following this order:

- pos. 1 (with spring recovery) hydraulic elevator lowers;
- pos. 0 (fixed) hydraulic elevator stops lowering and rising;
- pos. 2 (with spring recovery) hydraulic elevator rises.



Warning. It is sometimes necessary to regulate the implement lowering speed; this is achieved by tightening or loosening the flow regulator (2

Fig. 17) until the required lowering speed is obtained. The implement is locked by turning the flow regulator in the direction of the \ominus sign (clockwise); this is recommended for road circulation.

6.3.12.1 FRONT POWER LIFT

The two lower arms (1 Fig. 34) are activated directly by the simple-acting hydraulic jacks, while the upper third point (2 Fig. 34) can be adjusted manually by means of a revolving sleeve.

The main dimensions are shown in figure 42.

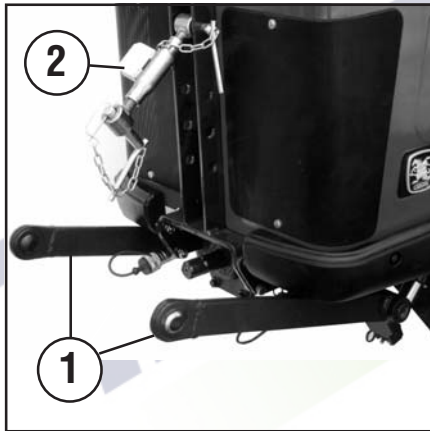

Fig. 34

6.3.12.2 REAR 3-POINT ELEVATOR

This is a standard feature, with class “1” lower arms (6 Fig. 35), perforated bar (7 Fig. 35) and upper tie-rod (5 Fig. 35). The main dimensions are shown in the diagram in figure 43.

Adjustment

The three-point hitch is supplied with tie rods which can be (4 Fig. 35) adjusted via a revolving collar in order to make it easier to attach and use the tools.

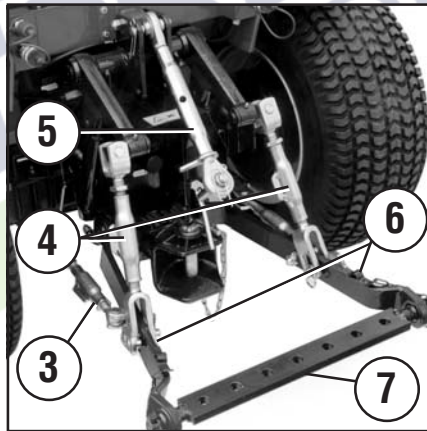

Fig. 35



Before starting work, always remember to reduce the lateral jolting of the tools by tightening the stabilising tie-rods (3 Fig. 35).



DANGER. Before lifting the implement make sure that all the hitches are in the locked position.

6.3.13 HYDRAULIC COUPLINGS

Upon request, the machine can be supplied with the following hydraulic couplings (Fig. 36 - 37) for attaching specific tools:

- nr. 1 Single-action hydraulic coupling (rear).
- nr. 2 Double-action, hydraulic coupling (rear).
- nr. 4 Double-action hydraulic intakes, two at the front and two at the rear.

- nr. 6 Hydraulic couplings:
 - four double-acting: two at the front (1-2 Fig. 36) and two at the rear (3-4 Fig. 37);
 - two single-acting (5-6 Fig. 37).

6.3.14 TOW-HOOKS

Front hook (optional)

The machine can be equipped with a front rigid pin hook, allowing it to be towed (Fig. 38).



WARNING. Do not tow any trailers or farming implements while in reversed drive.

Rear tow-hook

The machine is equipped with a rear fixed-type pin tow-hook (7 Fig. 39) or CBM hook (8 Fig. 40) for towing implements and trailers with one or more axles.

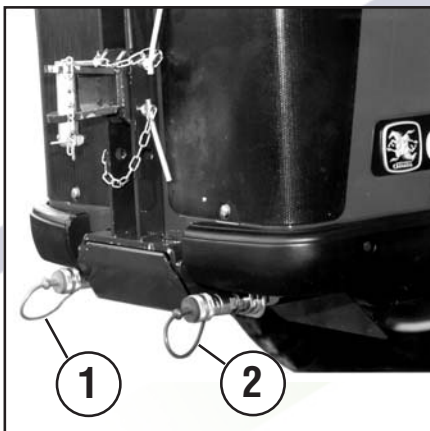

Fig. 36

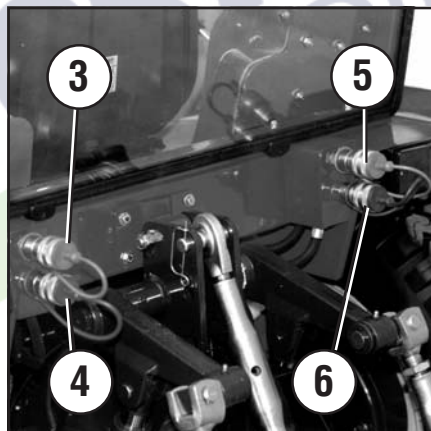

Fig. 37



Fig. 38

For the towing of farming implements in particular working conditions, the perforated bar (7 Fig. 35) can be used applied to the lower arms of the power lift.

WARNING. The perforated bar must be used at low speed and with light tools since sudden blows and rear ups of the machine may occur.

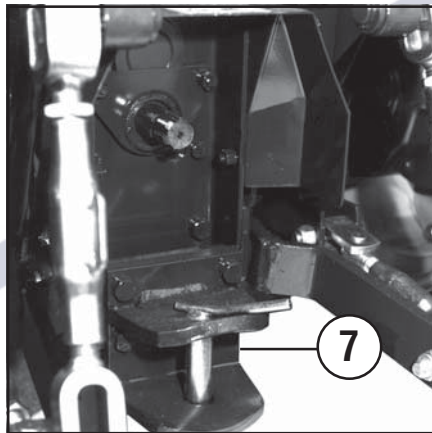

Fig. 39

6.3.15 REVERSIBILITY Reversal of driver's seat

DANGER. Carry out the reversal operations with engine off and parking brake engaged; proceed as follows:

- move lever (9 Fig. 41) to horizontal position to release the pin that locks the seat;
- raise the seat on the rear side and turn the hydroguide seat plate 180° in **counter-clockwise** direction;

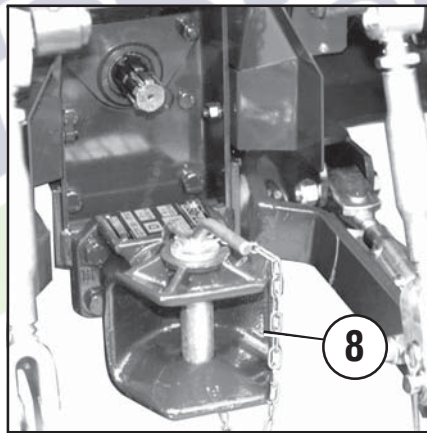

Fig. 40

- lower the seat and move the lever (9 Fig. 41) in vertical position making sure that the pin fits back into locking position;
- to restore normal driving, repeat the previous operations by rotating the hydroguide seat plate in **clockwise** direction.

WARNING. When turning the plate 180°, the flow inverter is automatically positioned so that the steering corresponds to the rotation direction of the steering wheel.

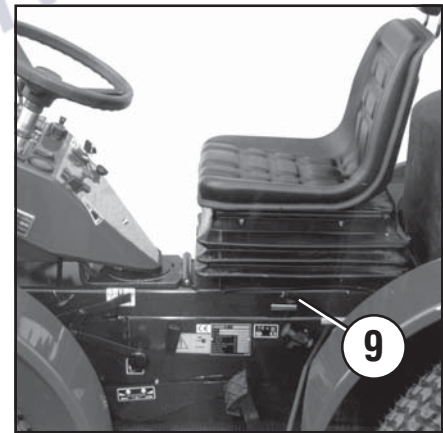

Fig. 41

6. USE INSTRUCTIONS

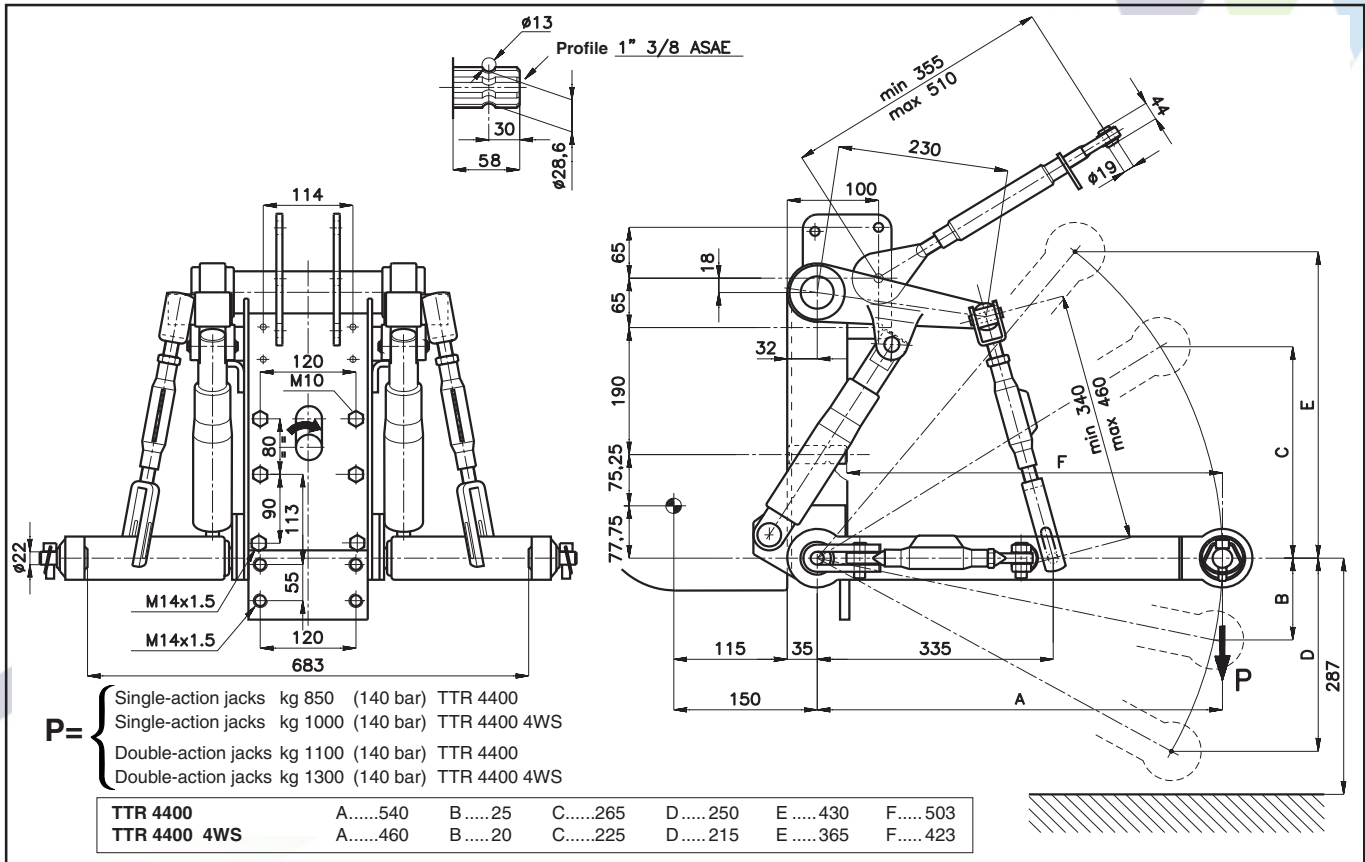

Fig. 43 - Dimensions of 3-point hitch and PTO flanging, with 6.50 - 16 wheels

6.3.16 AIR CONDITIONING SYSTEM

The roof of the Tigretac TTR 4400 30 series cab has been designed to permit the installation of an effective air conditioning system, which ensures proper and efficient air distribution inside the cab.

Specially designed to satisfy the most diverse needs of the user, the air conditioning system is the ideal solution for those who use the machine professionally.

This solution is integrated with the existing heating system with manual thermostatic control. This allows the user to obtain the

proper temperature and humidity inside the cab in every season.

To activate the system (with the engine running and powering the compressor), gradually rotate the thermostat switch (3 Fig. 44) for temperature control; the green telltale light should come on (2 Fig. 44); rotate the 3-speed electric fan switch to the desired position (1 Fig. 44).

The system has many possible uses. The air taken into the cab may be sucked from the outside and filtered through the activated carbon filters, or it can be internally recycled through the two suction vents located on the dashboard (4 Fig. 45).



DANGER. During pesticide treatment activated carbon filters must be used to ensure your safety. After each application they must be replaced with the standard paper type.

Do not use the activated carbon filters for any agricultural work other than pesticide treatments, since dust would clog the filtering element in a very short time. Keep the activated carbon filter in its original packing, reseal it carefully after each use. This filter should not be used for more than a total of 200 hours (if used properly); it has a maximum life of 36 months.

The activated carbon filter must not be washed or be blown with compressed air.

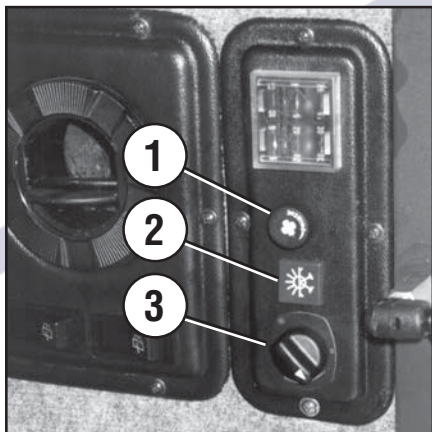

Fig. 44

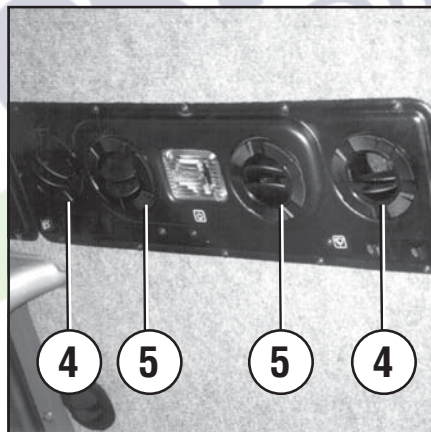

Fig. 45

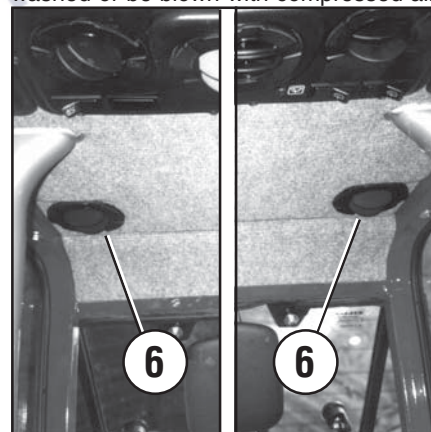

Fig. 46

6. USE INSTRUCTIONS

Change the filters at the first signs of toxic substance odour.

WARNING. The recirculation function is especially useful when the external air is polluted. However, extended use is not recommended.

Air diffusion in the cab is ensured by adjustable vents located in various areas of the cab.

The vents are positioned at the ends of the roof (6 Fig. 46, 7 Fig. 47) are adjustable to allow defogging of windscreens. The remaining vents, centrally located on

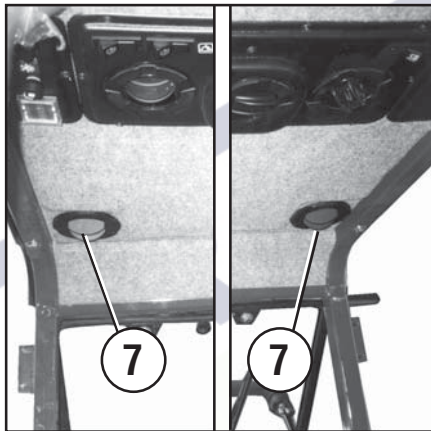

Fig. 47

the dashboard (5 Fig. 45) and in the lower part of the cab (8 Fig. 48), are connected by special ducts that convey the air and distribute it throughout the cab and even to the operator's feet, allowing for perfect temperature regulation.

Moreover, the hot air can be mixed by means of the temperature regulation knob (9 Fig. 49) and the cold air by means of the thermostat (3 Fig. 44). This provides an "air conditioner" effect.

WARNING. The system uses the "R 134 a" ecological cooling fluid. If accidentally spilled, it will not

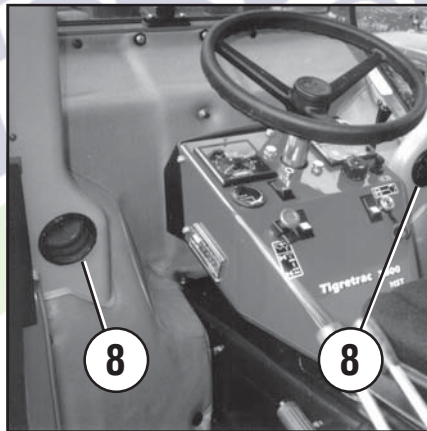

Fig. 48

harm the environment. Avoid using any other fluids which are incompatible with the system components.

To check or fill the system, contact an Authorized Service Center where qualified personnel are available.

WARNING. Do not use the recirculation function on humid, rainy or cold days as fogging of the cab windows will increase noticeably.

WARNING. Before starting or stopping the engine, always make sure that the air conditioning system is off.

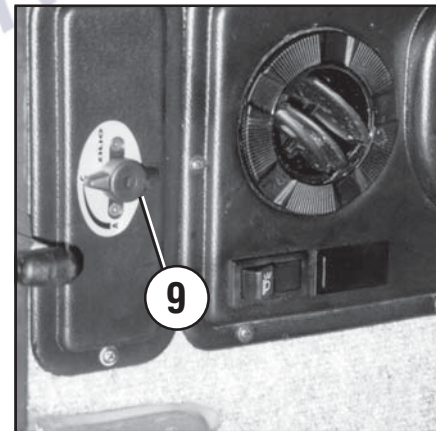

Fig. 49

7.1 GENERAL

The instructions for the proper maintenance of the machine are described below.

These instructions are merely indicative since they can vary according to the climatic conditions, the type of work environment and therefore they can be subject to changes that only the common sense and the experience of the operator can determine. Careful maintenance is of fundamental importance for the proper operation of the machine. Neglecting this fact, can cause harm to people and damage to property and the machine itself.

Periodical ordinary maintenance and daily checks must be carried out according to scheduled maintenance in accordance with the manufacturer's instructions.

Special maintenance, repair and particular adjustments must be performed by qualified and authorized personnel.



IMPORTANT. Disposal of oil and liquid wastes, dismantling and dumping of machinery must be performed by companies specialized and qualified in the processing of wastes.



WARNING. Before beginning maintenance, adjustments and repair, switch engine off, engage the parking brake and lower implements onto the ground.

7.2 ENGINE

As far as the engine is concerned, strictly observe the instructions given in the engine workbook, separately enclosed.

7.2.1 AIR FILTER

When the air filter is clogged, a warning light on the dashboard (13 Fig. 24) comes on and a buzzer sounds. Clean the filter proceeding as follows:

- 1 - first of all check that the rubber valve at the end of the cover (3 Fig. 50) is free, shaking out any material clogging it.
- 2 - remove filter cover (2 Fig. 50) from its seat, loosening the fastening screw;
- 3 - loosen the central fastening screw and remove the filter from its housing (1 Fig. 50);
- 4 - clean with a jet of dry air at a pressure that does not exceed 3 kg/cm^2 . Direct the jet onto the entire inner surface of the cartridge until dust is completely removed.

If compressed air is not available, beat the cartridge on the palm of the hand (never strike it with tools or beat it against the tyres).

More thorough cleaning should however be performed as soon as possible afterwards.

If the cartridge has oily spots, wash it with lukewarm water and a mild detergent. Rinse with clean water from the inside towards the outside at a pressure that does not exceed 2.8 bar.

Let the cartridge drip dry and then let dry at room temperature.

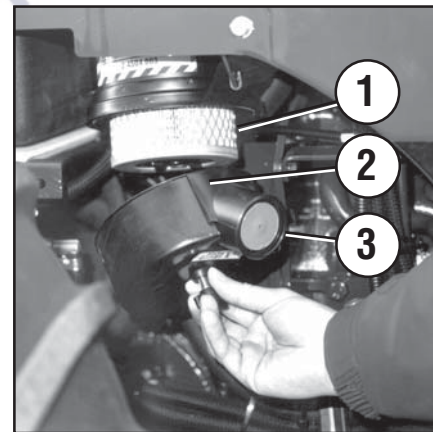

Fig. 50

Before reassembling the filter check the condition of the cartridge. If it is torn it must be replaced.

CAUTION. For maximum life and efficiency, the filter cartridge should only be cleaned when the air filter clogged warning light comes on. Cartridges must be changed after 5-6 cleaning operations and, in any case, do not exceed a 12 month's period prior to change.

7.2.2 COOLING CIRCUIT

Periodically, check the level of the fluid in the radiator. It must not drop below the MIN level indicator visible in the expansion tank, when the engine is cold (4 Fig. 51).

The fluid consists of a mixture of water and antifreeze, in proportion to prevent freezing down to temperatures of - 25°C, as explained by the sticker placed on the radiator.

A 50% mixture of water and antifreeze will provide antifreeze protection to about - 38°C. When unexpected losses make it necessary to top the system up with water only, the antifreeze level should be restored as soon as possible.

Check that the radiator fins are always clean. If necessary clean them with a jet of air.

WARNING. Remove the radiator cap only when the motor stopped and is sufficiently cooled. Slowly rotate cap to let pressure out before removing it completely.

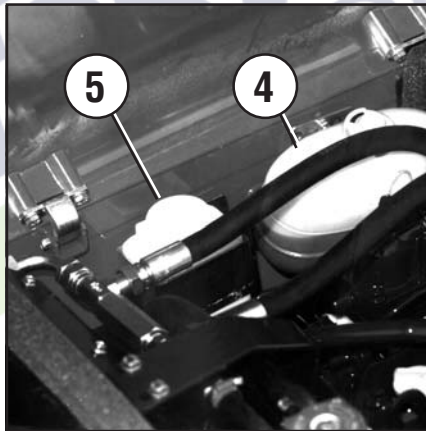

Fig. 51

7.3 WHEELS

Periodically check wear condition of the tires. Worn out, torn and cracked tires must be immediately changed proceeding as follows:

- 1 - stop engine;
- 2 - disconnect implements connected to the PTO;
- 3 - engage the parking brake and place chocks under each wheel;
- 4 - loosen wheel fastening nuts lightly;
- 5 - lift machine with jack located under transmission boxes;
- 6 - completely loosen the nuts and replace wheel.

CAUTION. Wheels or assembly parts must be similar to original ones.

Check the tyre air pressure regularly. Tyre pressure reference values are shown in the table on page 46.

For particular working conditions, especially when the machine works with heavy loads, consult the tire manufacturer directly.

Tire	Tire pressure (bar)	Tire pressure (bar)	
		front	rear
7.5L - 15	8PR	1,4	1,4
29x12.00 - 15	4PR	1,6	0,8
29x12.50 - 15	4PR	1,6	0,8
6.50 - 16	4PR	1,4	1,4
28x9.00 - 15	6PR	1,6	0,8
7.50 - 16	4PR	1,4	1,4

7.4 WINDSCREEN WASH LIQUID TANK

(On machines equipped with cab)

If the windscreen washer does not work properly, check that there is still liquid in the tank (5 Fig. 51). Top up using water mixed with products which can be easily found commercially. Also check that the spray nozzles are not clogged; if so, unclog them by using a needle.

7.5 CLUTCH

Periodically check the idle stroke of the clutch pedal. Excessive play will limit the clutch release stroke and may cause rough or faulty gear engagement. Insufficient play, on the other hand, may cause abnormal wear of the thrust bearing and difficulty in shifting.

7.5.1 CLUTCH ADJUSTMENT

A play value of approx. 15 mm, measured on the pedal bracket, is correct. When this value starts decreasing because of disk wear, you must make the necessary adjustments by means of the nut (1 Fig. 52), keeping in mind that when the nut is loosened the idle stroke increases, when it is tightened it decreases.

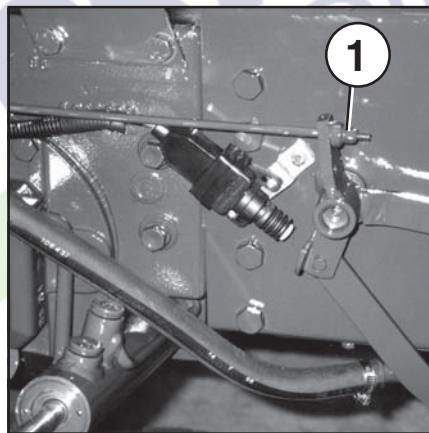

Fig. 52

7.6 FRONT AND REAR TRANSMISSION

Periodically check the oil level in the front and rear transmission.

Top up if oil level is too low.

Change the oil and the filter for the first time after 50 working hours in order to eliminate impurities caused by the running in of the moving parts.

Subsequent changes should take place at 400 working hour intervals.

7.6.1 FRONT TRANSMISSION

Check the oil level through the hole of the plug (3 Fig. 53). Oil level should be up to the rim of the hole, if not, add oil through the plug hole (4 Fig 54). Start machine at minimum speed and let it run for about 1 minute, then restore the oil level. Drain oil completely through the hole of the oil flange located underneath the front transmission box (2 Fig. 53).



WARNING. Under normal operating conditions the oil level should be checked every 50 working hours. However, if you are using implements operating with the oil in the case, the oil level must be checked and topped up immediately after the implement has been attached and tested.

7.6.2 REAR TRANSMISSION

Check the oil level through the hole of the plug (6 Fig. 55). Oil level should be up to the rim of the hole, if not, add oil through the plug hole (5 Fig. 55). Drain oil completely through the hole of the plug located underneath the rear transmission box (7 Fig. 56).

7.7 HYDRAULIC ELEVATOR OIL FILTER

Every 100 working hours take out the oil filter by removing the flange (2 Fig. 53) and clean it using commercial non-toxic solvents; do not use gasoline or kerosene. Reinstall it and check the oil level in the front case.

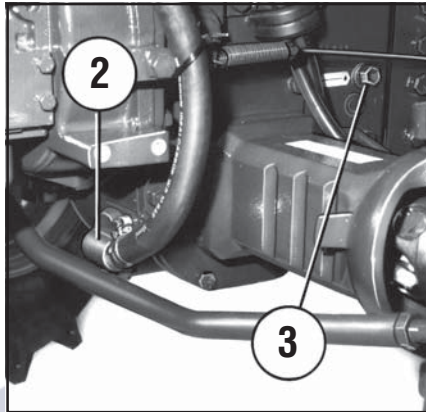

Fig. 53

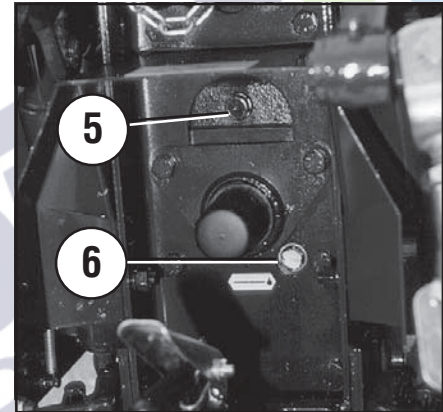

Fig. 55

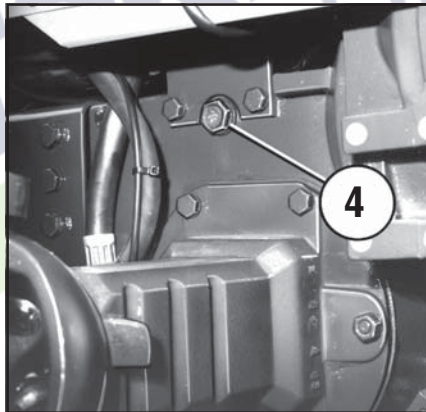

Fig. 54

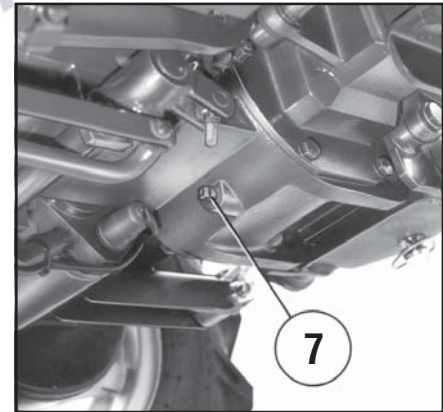

Fig. 56

7.8 HYDROSTATIC ENGINE OIL FILTER

When the pump sends the signal and the warning light on the dashboard (8 Fig. 24) lights up, it is necessary to change the hydrostatic transmission oil filter. Switch off the machine, loosen and remove the filter (1 Fig. 57) using the appropriate chain wrench. After this operation check the oil level in the rear transmission case.



CAUTION. Replace the filter at each oil change. After the initial 50 hours with the first oil change and, subsequently, every 400 hours.

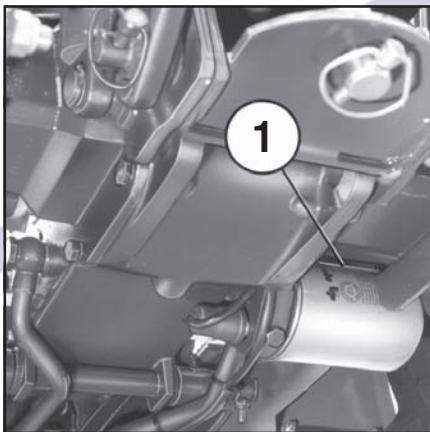

Fig. 57

7.9 BRAKES

Periodically check the adjustment of the braking system.

The adjustment of the brakes is necessary when the stroke of the brake pedal is excessive and the pedal almost reaches the end of stroke.

7.9.1 BRAKE ADJUSTMENT

In case of insufficient braking capacity due to the brake shoes wearing thin, adjustment must be made by turning adjustment nuts (2 Fig. 58); loosen to decrease travel.

When pedal is released, the nuts must be screwed tight to the tie rod pawl. To adjust

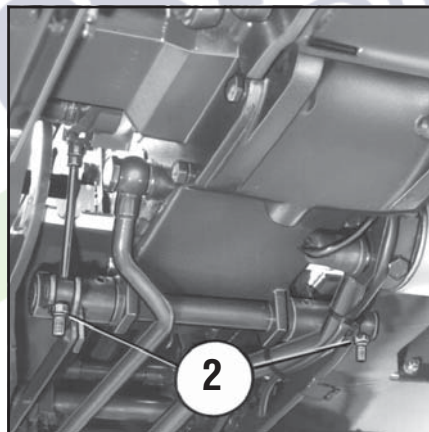

Fig. 58

the emergency and parking brake, regulate the brake adjuster (3 Fig. 59). For correct adjustment contact an authorized shop.

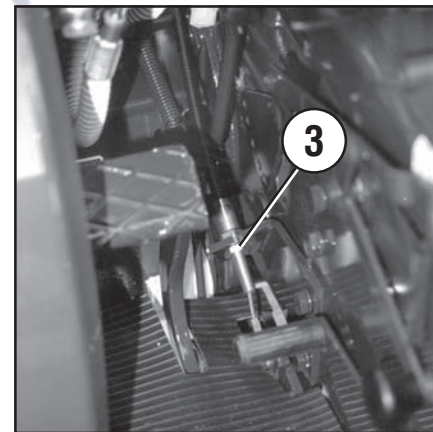

Fig. 59

7.9.2 HYDRAULIC BRAKES

Periodically check the brake fluid level in the tank (A Fig. 60). To top up, use Major DOT 3 brake fluid. Absolutely do not use fluids having different characteristics. If the operation of the braking system is irregular, contact an authorised repair shop.

WARNING. The brake fluid is hygroscopic, which means that in time it absorbs the humidity in the air. To ensure proper and reliable operation it must be changed completely at least once every two years.

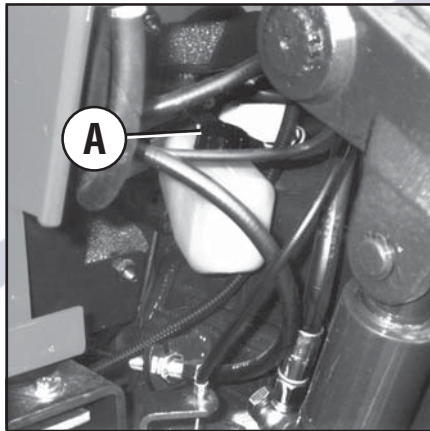

Fig. 60

7.9.2.1 ADJUSTING THE BRAKES

Front brakes

When due to wear of the brake shoes braking becomes insufficient, the brakes need to be adjusted. Proceed as follows:

- remove the affected wheel, following the instructions provided in paragraph 7.3 "Wheels";

- remove the plug that protects the small adjusting wheel from the hole;
- rotate the small wheel manually (B Fig. 61) to adjust the brake shoes;
- make sure that the brake pedal has no idle stroke; if necessary, adjust the small wheel again until the proper adjustment is obtained. When this operation has been completed, replace the plug in the hole and reassemble the wheel.

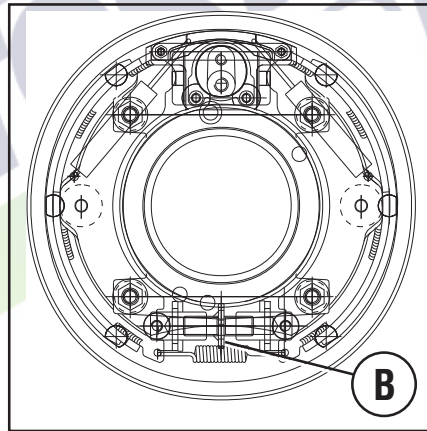

Fig. 61

Rear brakes

Loosen the nuts and adjust the push rods (C Fig. 62): when they are loosened the stroke decreases. When this operation has been completed make sure that the brake pedal has no idle stroke; if necessary adjust the push rods again until the proper adjustment is obtained. When the brakes have been properly adjusted tighten the nuts.

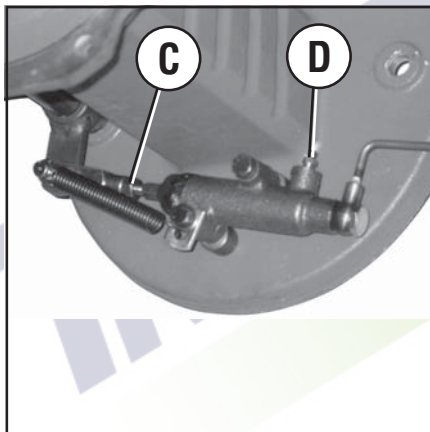

Fig. 62

7.9.2.2 BLEEDING THE BRAKES' HYDRAULIC CIRCUIT

Any time that you proceed to service the hydraulic system or whenever you notice abnormalities in the operation of the braking system, it is necessary to bleed the air. Contact an authorized repair shop or bleed the system yourself proceeding as follows:

- make sure that the brake supply tank is filled with brake fluid;
- step on the brake pedal;
- loosen the front deaerators (E Fig. 63) and

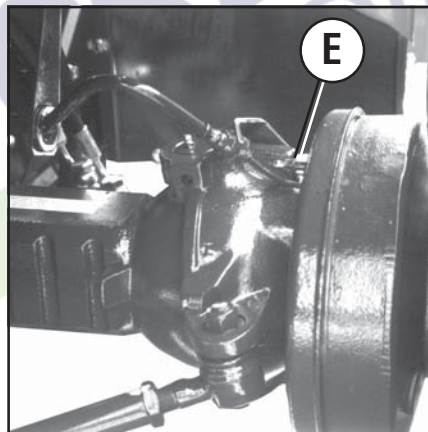

Fig. 63

rear deaerators (D Fig. 62) by half a turn, after cleaning them thoroughly;

- let flow the fluid mixed with air bubbles;
- re-tighten the deaerators;
- repeat the above operations until the flowing fluid is free from air bubbles;
- step on the brake pedals again to give pressure to the circuit;
- when these operations have been completed restore the fluid level in the tank.



WARNING. The right-hand and left-hand brakes must be adjusted in such a way that when braking the vehicle does not swerve or deviate from its course.



IMPORTANT. Check and adjust brakes regularly especially when working with heavy loads.

7.10 ELECTRICAL SYSTEM

7.10.1 BATTERY (4 Fig. 64)

Periodically check that the level of the electrolyte is approximately 10 - 15 mm. above the top edge of the plates (for standard maintenance batteries).

Top up with distilled water if necessary. Never use acids which might damage the battery. Use only distilled water. Keep the battery dry and clean in order to prevent current leakage which could have a corrosive effect.

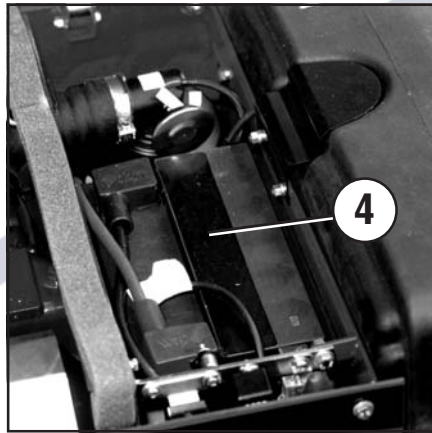

Fig. 64

If the machine remains inactive for a long period of time, it is good practice to store the battery in a dry place and recharge it every month.

7.10.2 LIGHTS

The machine, when travelling on public roads, must be in compliance with the Road Traffic Code of the country in which the machine is used, therefore the lights must also be perfectly efficient.

It is strongly recommended to check the condition of the lights and their adjustment. Proceed as follows (Fig. 65):

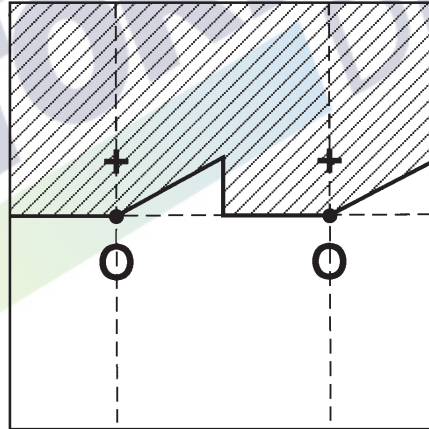

Fig. 65

- position the machine, loadless, with tires inflated at the proper pressure on a flat surface at 5 metres from a white wall, where possible, in the shade, and draw two reference crosses corresponding to the centre of the lights;
- when the lower beams are turned on, the reference points "O" must be underneath the two crosses at least 1/20 of the distance between the crosses and the ground;
- adjust lights by operating on the lights fastening three front screws (Fig. 66).

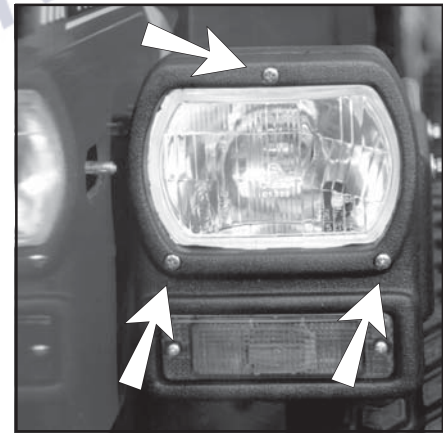

Fig. 66

7.10.2.1 REPLACING THE LAMPS

To replace the lamps:

- Front headlight.

Loosen the four r.-h. and l.-h. side screws (2 Fig. 67) and replace the lamps from the inside.

- Front light.

Loosen the screws that fasten the covers and replace the lamps (1 Fig. 67).

- Taillight.

Loosen the screws that fasten the covers and replace the lamps (3 Fig. 68).

- Licence plate light (on machines equipped with arch).

Loosen the screws (4 Fig. 69), remove the protection and replace the lamp.

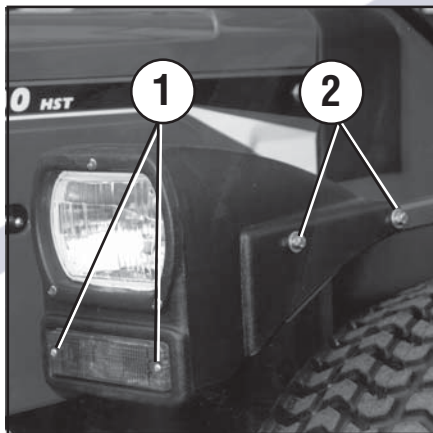

Fig. 67

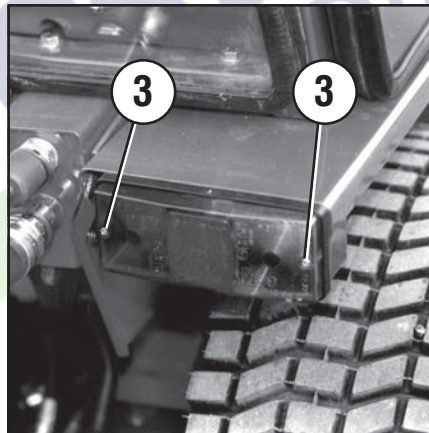

Fig. 68

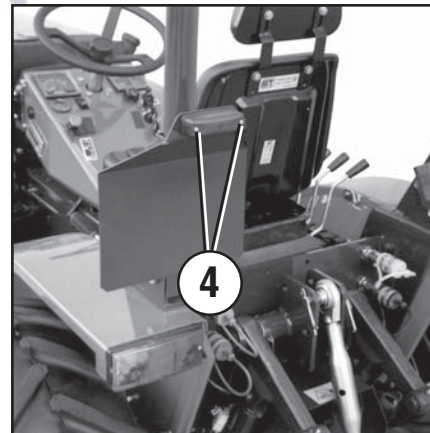

Fig. 69

- **Licence plate light (on machines equipped with chassis and cab).**

Loosen the screw (5 Fig. 70), remove the cover and replace the lamp.

- **Work light (on machines with frame).**

Loosen the screws (6 Fig. 70) that fasten the covers and replace the lamps.

- **Work light (on machines with cab).**

Loosen the screws (Fig. 71) that fasten the covers and replace the lamps.

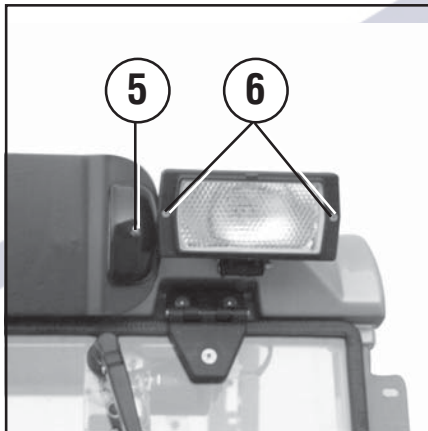

Fig. 70

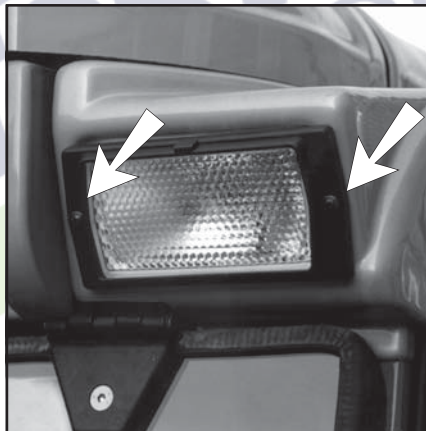

Fig. 71

7.10.3 FUSES

The electric system is protected by a set of fuses located in an easily accessible terminal board positioned on the dashboard (Fig. 72), and by a 40 A main fuse found near the starter.

Before replacing the fuse, locate the cause of the trouble.

After having located the cause and eliminated it, replace the fuse with another one having the same amperage.

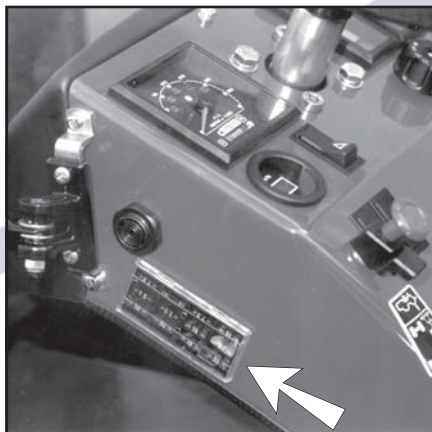

Fig. 72

For this purpose, remove the cover of the box and replace it.

Should the fuse continue to blow, have the electrical system, checked by qualified personnel.

FUSES

1	2	3	4
5	6	7	8
9	10	11	12

Fuse Protected circuit Amp.

- 1) Front r.-h. and rear l.-h. sidelights, Telltale light, licence plate light 7.5 A
- 2) Front l.-h. and rear r.-h. sidelights, Lighting instruments 7.5 A
- 3) Telltale light indicators, speedometer, speedometer sensor, time-rpm meter 7.5 A
- 4) Single-pole outlet, radio, courtesy light, four turn indicators 15 A
- 5) R.-h. lower beam 7.5 A
- 6) L.-h. lower beam 7.5 A
- 7) Work lights, optional kit, front PTO, alarm buzzer 15 A
- 8) Four turn indicators, heater... 25 A
- 9) R.-h. and l.-h. high beam 10 A
- 10) Electromagnet recharger, switchboard supply, alternator . 10 A
- 11) Stop lights, windshield wipers, windshield washer reservoir 15 A
- 12) Horn 10 A

7.10.4 ELECTRIC SYSTEM

7.10.4.1 GENERAL WIRING DIAGRAM AND COMPONENTS

B1	Battery	H14	Rear licence plate light	P2	Hour counter
FG	40 A fuse	H15	Licence plate light for reversibility	P3	Thermometer
FU1	7.5 A fuse, front r.-h. and rear l.-h. sidelights, indicator light, licence plate light	H16	L.-h. tail light	P4	Speedometer
FU10	10 A fuse, electromagnet recharger, switchboards, alternator	H17	R.-h. tail light	R1	Glow plug
FU11	15 A fuse, stop and cab lights	H18	L.-h. light for reversibility	R2	Water temperature transducer
FU12	10 A fuse, horn	H19	R.-h. light for reversibility	S1	Start panel
FU2	7.5 A fuse, front l.-h. and rear r.-h. sidelights, instrument panel lights	H2	Hand brake indicator light	S10	Micro hand brake
FU3	7.5 A fuse, telltale lights, instruments, speedometer sensor	H20	L.-h. headlight	S11	Speedometer sensor
FU4	15 A fuse, 4 turn indicators, 30+ cab line	H21	Front l.-h. sidelight and turn indicator light	S12	Front PTO switch
FU5	7.5 A fuse, r.-h. lower beam	H22	R.-h. headlight	S13	Light switch
FU6	7.5 A fuse, l.-h. lower beam	H23	Front r.-h. sidelight and turn indicator light	S14	Stop switch
FU7	15 A fuse, work lights, optional kit, front PTO, alarm buzzer	H24	L.-h. headlight for reversibility	S15	Turn indicator switch
FU8	25 A fuse, 4 turn indicators, 15+ cab	H25	R.-h. headlight for reversibility	S16	Warning switch
FU9	10 A fuse, upper beams	H3	Generator indicator light	S17	Work light switch
G1	Alternator	H4	Glow plug indicator light	S4	Start consent limit switch
H1	Engine oil pressure indicator light	H5	Work light	S5	High water temperature thermostat
H10	Fuel reserve indicator light	H6	Trailer turn indicator telltale light	S6	Air filter
H11	Engine air filter indicator light	H7	Sidelight indicator light	S7	Hydraulic oil filter
H12	Oil filter indicator light	H8	Turning light indicator light	S8	Low oil pressure switch
H13	Water temperature indicator light	H9	Upper beam indicator light	V1	Diode
		HA1	Alarm buzzer	V2	Diode
		HA2	Horn audible signalling device	V3	3 A buzzer diode
		K1	Starter relay	V4	3 A buzzer diode
		K2	Preheating timer	V5	1 A instrument supply diode
		K3	Engine switch-off timer	V6	3 A parking light diode
		K4	Engine switch-off relay	Y1	Engine switch-off electric valve
		K6	Intermittence	Y2	Front PTO electric valve
		M1	Starter	X1	4-way connector
		M2	Windshield washer pump	X10	3-way connector
		P1	Revolution indicator	X11	90° 2-way connector
				X12	2-way connector

X13	5-way connector combination 1	X6	9-way connector
X14	4-way connector combination 2	X7	3-way connector
X15	4-way connector combination 1	X8	2-way connector
X16	5-way connector combination 1	X9	4-way connector
X17	5-way connector combination 2		
X18	3-way connector		
X19	2-way connector		
X2	12-way connector		
X20	2-way connector		
X21	Trailer connector		
X22	2-way connector		
X23	2-way connector		
X24	4-way connector		
X25	4-way connector		
X26	4-way connector		
X27	4-way connector		
X28	6-way connector		
X29	3-way connector		
X3	21-way connector		
X30	6-way connector		
X31	3-way connector		
X32	3-way connector		
X33	3-way connector		
X34	3-way connector		
X35	90° 2-way connector		
X36	2-way connector		
X4	21-way connector		
X40	90° 2-way connector		
X41	2-way connector		
X42	1-way connector		
X5	4-way connector		

COLOUR DESCRIPTION

A	Light blue
B	White
C	Orange
G	Yellow
H	Grey
L	Blue
M	Brown
N	Black
R	Red
S	Pink
V	Green
Z	Purple

7. MAINTENANCE

1	2	3	4	5	6	7	8	9	10	11	12	13	14	15	16	17	18	19	20
---	---	---	---	---	---	---	---	---	----	----	----	----	----	----	----	----	----	----	----

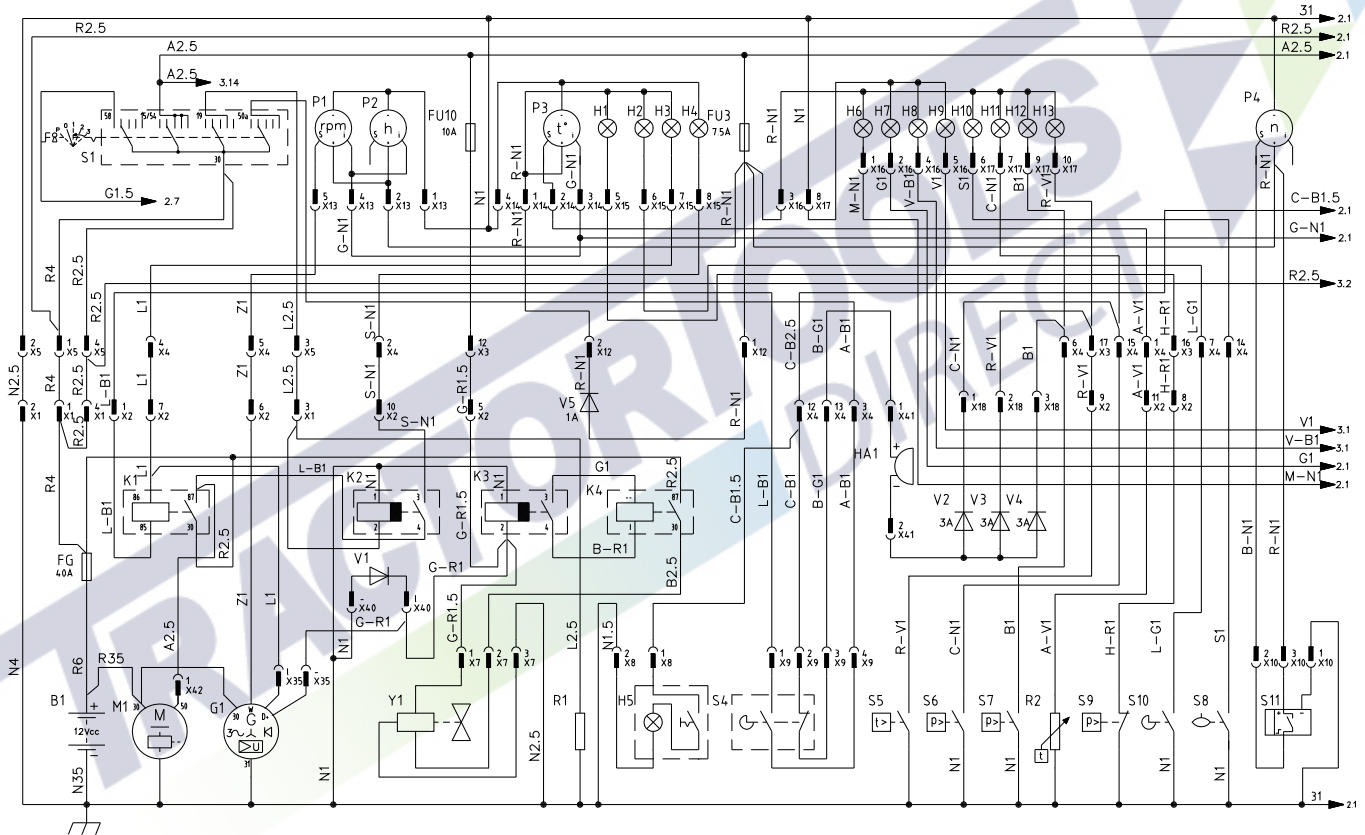

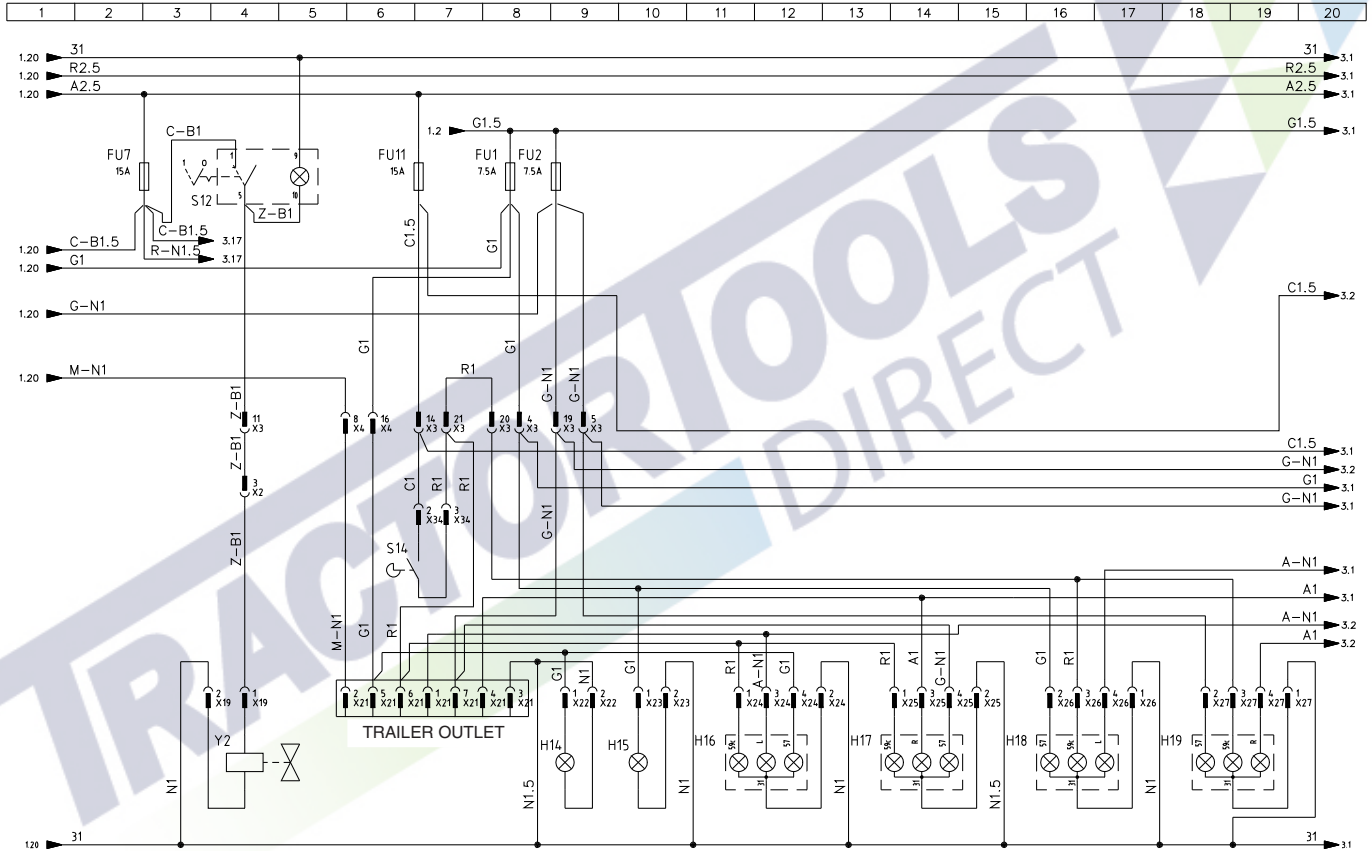

7. MAINTENANCE

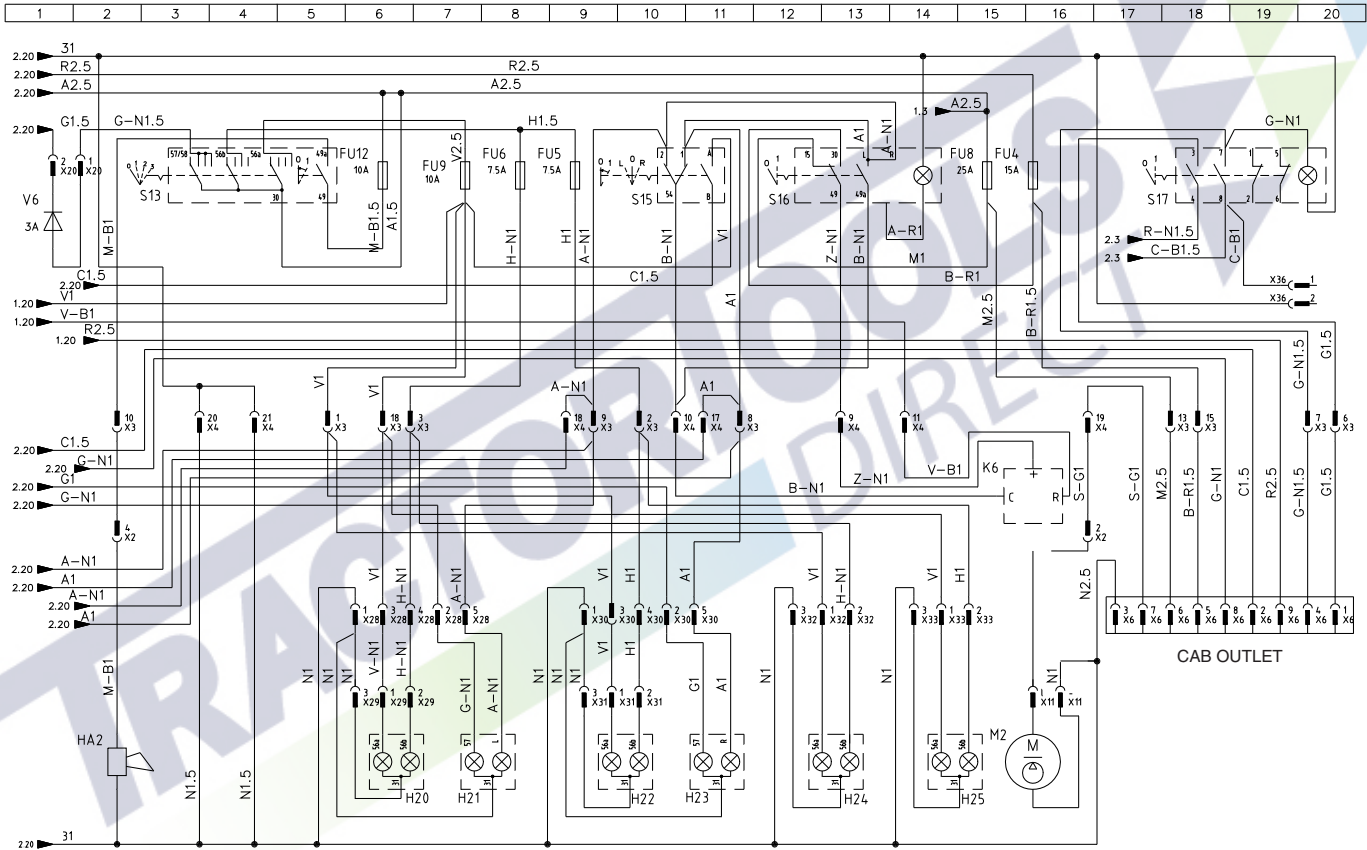

7.10.4.2 CAB COMPONENTS AND WIRING DIAGRAM

- 1 Ceiling lamp
- 2 Front wiper motor connector
- 3 Compressor
- 4 Single-pole outlet
- 5 Thermostat with switch
- 6 Indicator light
- 7 3-speed switch
- 8 Centrifugal electric fan
- 9 Pressure switch
- 10 Electric fans
- 11 Licence plate light connector
- 12 Work light
- 13 Rear wiper motor connector
- 14 Work light

COLOUR CODES

- A Orange
- B White
- C Pink
- D Grey
- E Green
- F Blue
- G Yellow
- H Light blue
- M Brown
- N Black
- R Red
- V Violet

7. MAINTENANCE

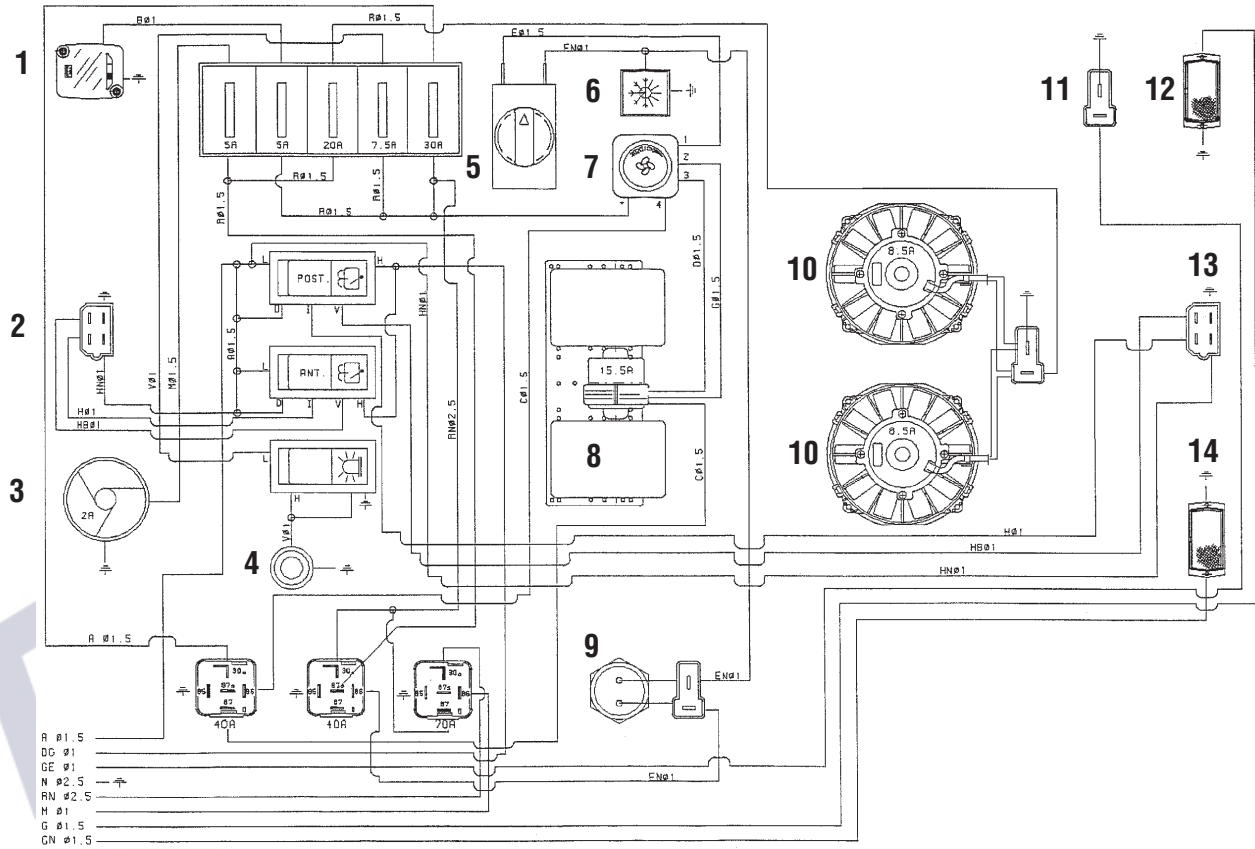

7.10.4.3 WIRING DIAGRAM AND COMPONENTS OF 4WS STEERING

- 1 Wheel centring control switch
- 2 System supply connector
- 3 Wheel centring electric valve
- 4 Relay unit
- 5 Front wheel centring sensor
- 6 Rear wheel centring center

COLOUR CODES

- A Light blue
- B White
- C Orange
- D Yellow
- H Grey
- L Blue
- M Brown
- N Black
- R Red
- S Pink
- V Green
- V Violet

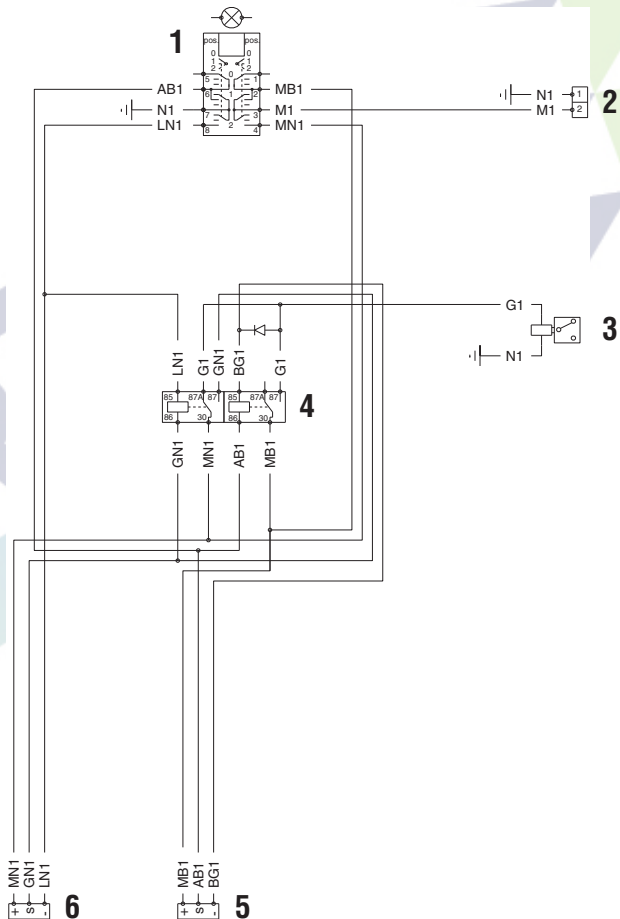

7.11 LUBRICATION

Preliminary operations

The machine is delivered with all its components fully lubricated. However, in order to achieve maximum efficiency and a long working life, the machine requires proper maintenance as listed in the diagram. As for the engine refer to the instructions and procedures listed by the manufacturer in the engine's instruction booklet. Before lubricating the machine, carefully clean all the dirt and mud deposits from the parts to be lubricated, nipples and plugs, in order to prevent dirt and dust from entering together with the new lubricant. All oil level checks must be carried out with the engine off and the machine perfectly levelled. The machine is lubricated with products specified in the lubrication table. If you wish to use different products, make sure that they are of a corresponding type. In any case, never mix different products together. Always wash the machine after use on dusty or muddy soil, then lubricate all the grease points and the various linkage joints by means of grease nipples or oilers.

For maintenance operations described in the following chapter, refer to the maintenance table on pages 64-65-66 and the diagram shown on pages 67-68.

TABLE OF RECOMENDED OILS

Engine	Mobil Agri Super 15 W 40
Front lift box	Mobil Agri Super 15 W 40
Rear gearbox	ESSO UNIFARM 10 W 30 Temp. over 0°C ESSO TORQUE FLUID 47 Temp. under 0°C
Grease nipples	Mobilube Grease XHP 222
Brake control	Major DOT 3

7.11.1 MAINTENANCE TABLE

	As needed	Every 8 Hours	Every 50 Hours	Every 150 Hours	Every 250 Hours	Every 400 Hours	Every 500 Hours	Every 1000 H. or 1 years	Every 2000 H. or 2 years
ENGINE									
1) Check engine oil		●							
2) 1 st engine oil change			●						
3) Change engine oil					●				
4) 1 st oil filter change			●						
5) Replace oil filter					●				
6) Replace fuel filter							●		
7) Check fan-alternator belt tension		●							
8) Replace fan-alternator belt					●				
AIR FILTER									
9) Clean air filter	●		●						
10) Replace air filter	●								
COOLING CIRCUIT									
11) Check cooling liquid level			●						
12) Change cooling liquid								●	
13) Clean radiant masses screen and grids	●	●							
14) Clean outer surface of radiant masses	●					●			
WHEELS									
15) Check tire pressure				●					

7. MAINTENANCE



	As needed	Every 8 Hours	Every 50 Hours	Every 150 Hours	Every 250 Hours	Every 400 Hours	Every 500 Hours	Every 1000 H. or 1 years	Every 2000 H. or 2 years
16) Tighten wheel fastening bolts				●					
17) Replace wheel	●								
WINDSCREEN WASH LIQUID									
18) Check windscreen wash liquid			●						
CLUTCH									
19) Clutch pedal travel	●								
FRONT DRIVE									
20) Check oil level			●						
21) Change 1 st oil			●						
22) Change oil						●			
REAR DRIVE									
23) Check oil level			●						
24) Change 1 st oil			●						
25) Change oil						●			
26) Replace oil filter 1 st change (hydrostatic engine)			●						
27) Replace oil filter (hydrostatic engine)	●					●			
BRAKES									
28) Check brake fluid			●						
29) Change oil									●

	As needed	Every 8 Hours	Every 50 Hours	Every 150 Hours	Every 250 Hours	Every 400 Hours	Every 500 Hours	Every 1000 H. or 1 years	Every 2000 H. or 2 years
30) Adjust brakes	●								
31) Bleed brake system	●								
ELECTRIC SYSTEM									
32) Replace light bulbs	●								
33) Replace fuses	●								
34) Check electrolytic level				●					
GREASING (see diagram page 68)									
A) Front elev. arm connection (1+1 grease nipple)	●		●						
B) Front elevator jacks (1+1 grease nipple)	●		●						
C) Front wheel artic. joints (2+2 grease nipple)	●		●						
D) Front steering jack (2 grease nipple)	●		●						
E) Brake pedals (2 grease nipple)	●		●						
F) Brake pedal support (2 grease nipple)	●		●						
G) Rear elev. arm connection (1+1 grease nipple)	●		●						
H) Rear elevator jacks (1+1 grease nipple)	●		●						
I) Rear elevator upper shaft (1 grease nipple)	●		●						
L) Rear wheel artic. joint (4WS) (2+2 grease nipple)	●		●						
M) Rear steering artic. joint (4WS) (1+1 grease nipple)	●		●						

7. MAINTENANCE

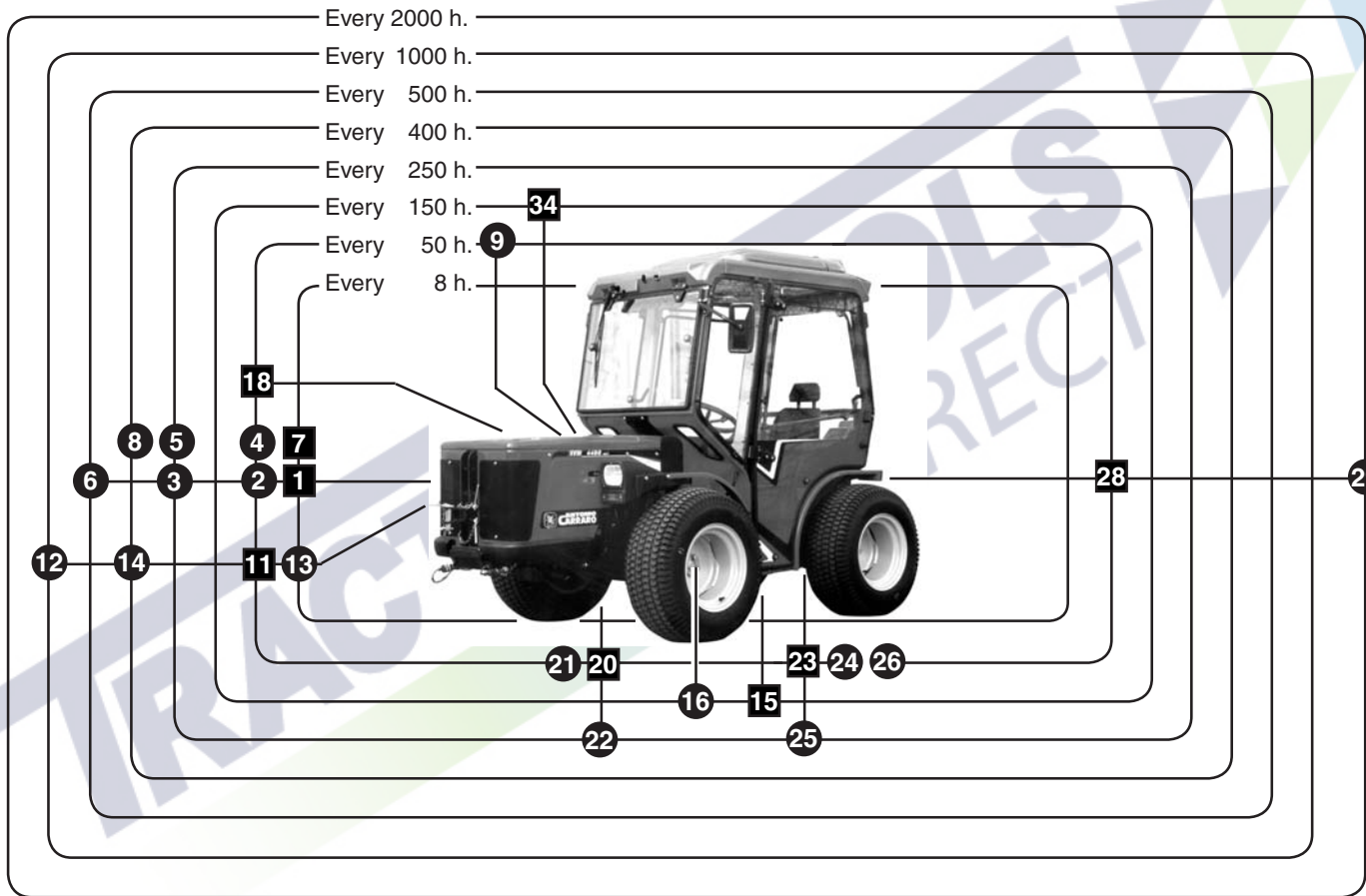

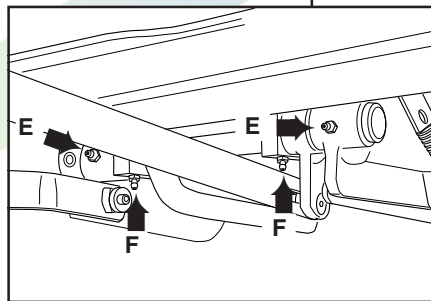
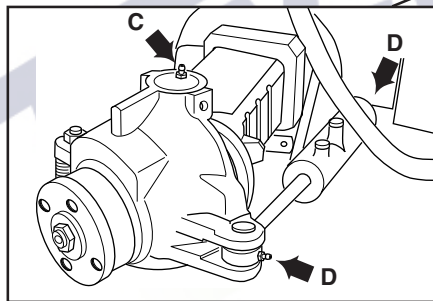
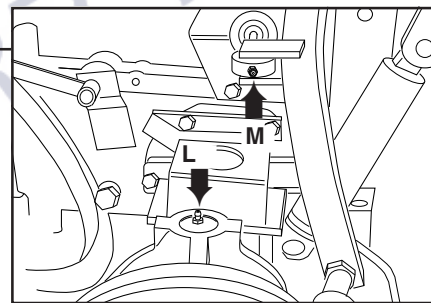
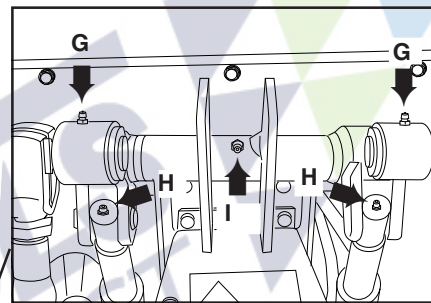
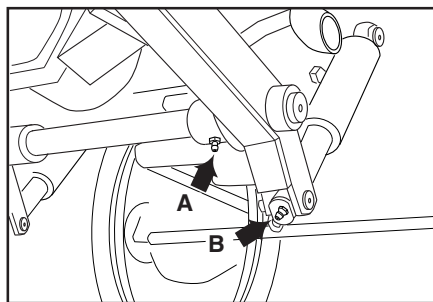

7.12 TROUBLESHOOTING

<i>TROUBLE</i>	<i>CAUSE</i>	<i>SOLUTION</i>
1) The starter does not turn.	<ul style="list-style-type: none"> - Battery down. - Cable clamps of the battery are oxidised. - Fuse tripped. - Start enable switch not engaged. - Start enable switch does not work. - Faulty start switch. - Faulty starter. 	<ul style="list-style-type: none"> - Check battery, charge or replace it. - Check clamps, clean or lubricate. - Replace fuses. - Press clutch pedal all the way. - Replace switch. - Replace switch. - Consult an authorized repair shop.
2) Motor does not start.	<ul style="list-style-type: none"> - Clogged fuel filters. - Jammed injection pump solenoid valve. - Pump solenoid valve not energized. - Air in fuel circuit. 	<ul style="list-style-type: none"> - Check and if necessary replace filters. - Consult an authorized repair shop. - Check and if necessary replace fuses and consult an authorized repair shop. - Remove air from supply system.
3) Excessive grade of smoke.	<ul style="list-style-type: none"> - Dirty or out-of-phase injectors. 	<ul style="list-style-type: none"> - Check injector, clean or replace them.
4) Engine water temperature too high.	<ul style="list-style-type: none"> - Radiator is dirty. - Lack of cooling liquid in the radiator. 	<ul style="list-style-type: none"> - Clean radiator. - Check and add liquid if necessary, and bleed the circuit.

TROUBLE	CAUSE	SOLUTION
5) Excessive travel of the brake pedals.	<ul style="list-style-type: none"> - Brakes not properly adjusted. - Oil level too low. - Brake oil circuit takes in air. - Oil leaks in the brake circuit. 	<ul style="list-style-type: none"> - Adjust brakes. Consult an authorized repair shop. - Check level and if necessary restore it. - Consult an authorized repair shop. - Consult an authorized repair shop.
6) Faulty cab heating.	<ul style="list-style-type: none"> - Clogged top air filter. - Not enough cooling liquid in radiator. 	<ul style="list-style-type: none"> - Clean air filter and if necessary replace it. - Check and add liquid if necessary.
7) Nonuniform wear of tires.	<ul style="list-style-type: none"> - Improper inflation of tires. 	<ul style="list-style-type: none"> - Inflate tires at recommended pressure.
8) Power lift does not work.	<ul style="list-style-type: none"> - Excessive weight of implements. - Lack of oil in gearbox. - Low pressure of the hydraulic circuit. 	<ul style="list-style-type: none"> - Use more suitable implements. - Check oil level and top up if necessary. - Have pressure checked by an authorized repair shop.

8.1 SPARE PARTS

Please indicate the following in your request for spare parts to Antonio CARRARO area dealer:

The type and serial number of the machine. This information is marked on the machine identification plate (see page 5).

MAXIMUM MACHINE PERFORMANCE AND DURABILITY
CAN ONLY BE ACHIEVED BY USING GENUINE SPARE PARTS.

ANTONIO CARRARO spa

WILL ONLY GRANT YOU GUARANTEE COVERAGE WHEN GENUINE SPARE PARTS HAVE BEEN USED.

Our AREA DEALER is always at your complete disposal for any information or advice.



Progetto grafico
&
Fotocomposizione

TECHNOLAB
COMMUNICATION

Bassano del Grappa (VI)
Tel. 0424 50.09.78

September 2008

Our factory works constantly to improve all its models. We therefore ask you to be understanding if we reserve the right to introduce, without prior notice, modifications regarding shape, equipment, and technical features of the requested vehicle. It will, therefore, not be possible to claim rights on the basis of the data, the instruction and the descriptions contained in the hereby «Use and Maintenance» manual.

2008 Antonio Carraro spa



Tractor people

Antonio Carraro spa
Via Caltana, 24 - 35011 Campodarsego Padova
Telefono 049 921 99 21 - Fax S.A.T. 049 921 99 99
<http://www.antoniocarraro.it>

Cod. 4.7302.131/02