

ENGLISH

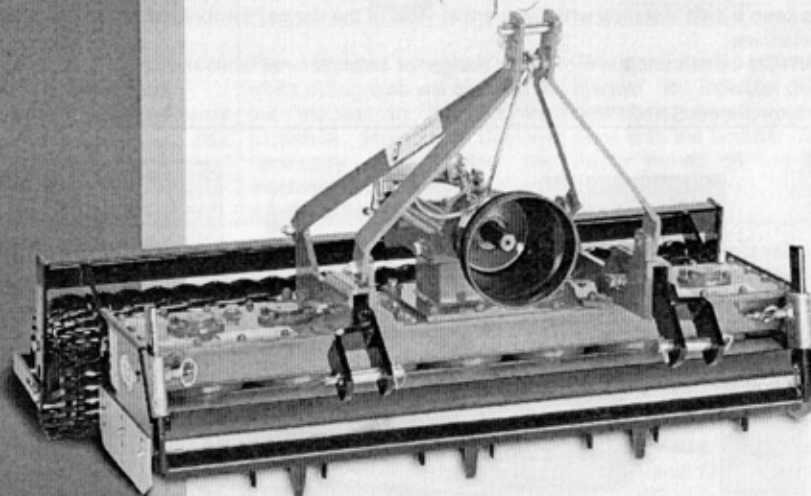

*A professional choice*



**Mill Grader**  
**Mod. MTZ - MTZhi**  
**Instructions and maintenance manual**  
*(Translation of the original instructions)*

Made in Italy  
[www.R2RINALDI.com](http://www.R2RINALDI.com)

1P063

Index	Pag.
Introduction.....	3
Machine identification.....	3
Description of the machine and its proper use.....	4
Technical specifications and dimensions.....	5
Handling and transportation of the machine.....	5
Accident prevention.....	6
Components assembly and coupling of the working equipment.....	7
Cardan shaft connection.....	8
Preparation for use.....	9
Working depth adjustment.....	9
Levelling adjustment.....	9
Machine use.....	10
Maintenance.....	11
Hoes replacement.....	12
End of work and storage of the machine.....	13
Scrapping and disposal of the components and packaging.....	13
Specific references for the hydraulic machines.....	14
Guarantee and Certification.....	18

**WARNING**

Always keep a safe distance when you are in view of the danger symbol placed on the side and back of the machine.

ATTENTION cardan shaft in movement,danger of entanglemnet while turning. DO NOT TOUCH..DO NOT GO NEAR.

PTO tractor speed: 540 RPM

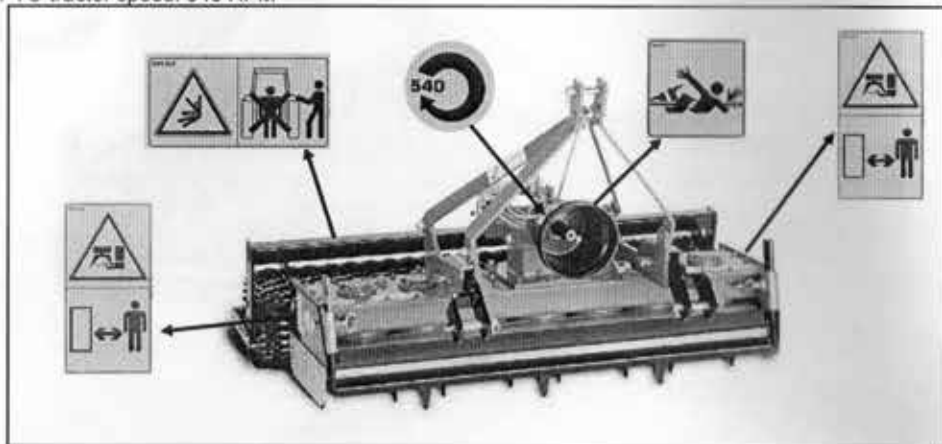

Before using the machine read the instruction booklet.



Turn off the walking tractor or tractor before making any adjustment in the machine , take the key and read the instruction booklet.

**Introduction**

We would start by thanking you for having chosen our product and hope that you will be happy with your choice.

In order that your **MILL GRADER Mod. MTZ-MTZhi** can offer the maximum efficiency for many years, we ask you to pay attention to the instructions for use and maintenance which you will find in this manual. Observance of these regulations will prevent breakdowns and accidents for which our company will not accept responsibility.

This use and maintenance manual is to be considered an integral part of the machine and therefore it must always accompany the machine when it is sold, even in the event of its sale to third parties. If you keep this manual in a safe place and in good condition, you - and whoever must use the machine - will be able to have a complete, legible reference on hand at all times.

**Description of the symbols used in the manual**

This symbol will be used in the manual to indicate actions ( misuse ) elements, behaviours and situations that could risk your security and the one of other people.	The rounded symbols with white pictograms will be used in the manual to indicate the Individual Protective Devices necessary while using the machine or while making any adjustments.	This symbol will be used in this manual to indicate that the described operation must be done with the walking tractor or tractor turned off and the key disconnected

**NOTE:** This manual concerns the use and maintenance description of the mechanic mill graders MTZ, which corrisponds largely to the hydraulic models MTZhi ; the differences between the two models will be indicated with a caption

(\*note *n* mod. hi) (*n* indicates the note number)

and examined in an specific section of the manual.

**1 - Machine identification**

Each R2 machine has a CE plate with the main details of the R2 company and of the machines. The plate is positioned on the upper part of the machine(models MTZ 100 and 120 - MTZhi) or on the reduction gear (models MTZ 135-150-170 and 190).

Fig. 1



**2 - Description of the machine and its proper use**  
(\*nota 1 mod. hi)

The **MILL GRADER Mod. MTZ-MTZhi** is the only machine that applied to low powered tractors levels, mills and compresses the soil in a single operation.

As can be seen from the illustration (Fig.2), the **MILL GRADER Mod. MTZ-MTZhi** is equipped with an adjustable -height scrapper on the front to shift the earth, a central rotating harrow to mill the soil and a special grinded roller at the back, which makes it possible to adjust the working depth of the rotating harrow and to compress the soil.

The **MILL GRADER Mod. MTZ-MTZhi** is used in the preparation of the soil for fields, gardens, sporting facilities, vegetables, gardens and for anyone who needs the ground to be perfectly levelled.

Fig. 2

- A - Main body of the machine (harrow)
- B - Roller group.
- C - Register roller adjustment
- D - Hoes
- E - Scraper
- F - Screws adjustment scrapper
- G - Three-point linkage
- H - Side and side extension.
- I - Protections.

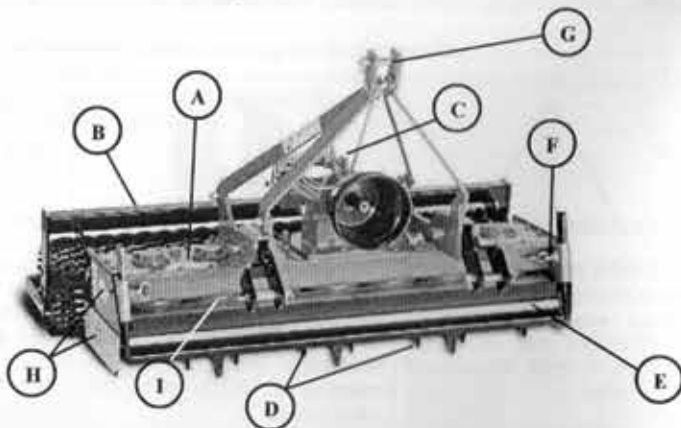

**!** THE **MILL GRADERS Mod. MTZ-MTZhi** are designed to be applied exclusively to professional driven tools (tractors with three-point linkage and PTO 540 r.p.m. or hydraulic drive) with CE certificate of appropriate HP and to prepare the soil.

Any other type of use is considered improper and so dangerous. In all those cases that the **MILL GRADERS Mod. MTZ-MTZhi** are used for different purposes of those determined, the manufacturer disclaims any liability for damages of any nature.

Read always the instruction booklet of the working equipment (tractor) before fitting and using the **R2** machine.

The proper use of the machine implies:

- The respect of the rules of use and maintenance established by the manufacturer and gathered in this manual.
- the exclusive use of spare parts and original **R2** accessories.

The machine must be used, maintained and repaired only by competent staff.

The qualified staff enabled to use the machine must be properly trained and informed of the proper use of the equipment and the risks that could be run. The user is required to comply with the rules and existing Legislation relating to fire prevention, safety at work and traffic in public roads.

**3 - Technical specifications and dimensions**  
(\*note 2 mod. hi)

	Modelo				
	MTZ100	MTZ120	MTZ 135	MTZ 150	MTZ 170
Milling width (Fig. 3 - Ref. A)	90 cm	105 cm	122 cm	140 cm	155 cm
Levelling width (Fig. 3 - Ref. B)	90 cm	105 cm	122 cm	140 cm	155 cm
Compactness width (Fig. 3 - Ref. C)	100 cm	116 cm	132 cm	150 cm	170 cm
Depth (Fig. 3 - Rif D)	75 cm	75 cm	75 cm	75 cm	75 cm
Maximum height from the ground (Fig. 3 - Ref. E)	87 cm	87 cm	87 cm	87 cm	87 cm
Tractor HP	14-18 HP	16-25 HP	20-30 HP	25-30 HP	30-35 HP
Maximum working depth	16 cm	16 cm	16 cm	16 cm	14 cm
Number of Hoes	10	12	14	16	18
Weight	170 Kg	200 Kg	250 Kg	285 Kg	320 Kg

Lubricant main body machine: ROLOIL LITEX - EP/1

Gear box lubricant only models MTZ 135-150-170) : ROLOIL Dolomiti super HD Turbo/15W40

**!** Note: Emission of airborne noise. The noise produced by the machine varies according to the soil features at work. Exposure also depends strictly on the noise produced by the tractor. Considering the data in the literature relating to similar equipment, it can be considered an approximate value of exposure to the noise determined by the tractor between 90 dB (A) and 95 dB (A).  
Verify the level of exposure to the noise with the proper instruments each time any work is performed. Follow the legislative references of your country to identify the personal protective necessary equipment

Fig. 3

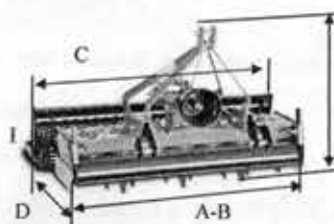

Fig. 4a

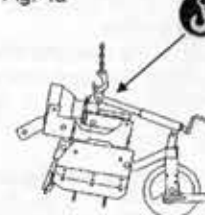
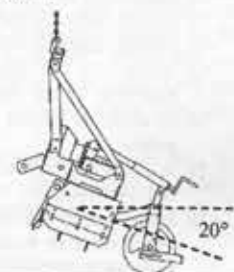

Fig. 4b



**4 - Handling and machine transportation.**  
(\*note 3 mod. hi)

- The machine must be handled with lifting equipment. Make sure that such equipment (including the straps and the strings) have a carrying capacity appropriate to the weight to be lifted and that they are in good maintenance conditions.

The machine can be anchored:

- a) while unpacking it (three point linkage frame not assembled); through the coupling point on the machine (Fig. 4a).
- b) machine completely assembled through the three point pin (Fig. 4b)

Due to the centre of gravity, the machine will lean about 20° while lifting it.

**!** In order to make handling operations safely, always wear safety shoes and make sure that there are no people or animals nearby while working

- The machine must be transported by professional means of conveyance (trucks, vans, etc.). Do not use carry the machine in a car. In all cases, before transporting the machine, make sure that it is well anchored with straps and strings and that it is stable enough. The anchor points can be the roller group support, the three point linkage pin, the coupling tractor arms, and the front scraper. Make sure that the scraper adjustment screws are properly tightened.

Always check that any walkways, ramps, etc. that must be crossed are well anchored and have a capacity capable of supporting the total load of the vehicle + machine + operator. When using ramps for loading, ensure that the vehicle has the handbrake on and have been positioned the wedges suitable for locking the wheels

**5 - Accident prevention**  
(\*note 4 mod. hi)



Most accidents that happen at work, during the maintenance or the shifting of a machine, are due to negligence in the observance of the most elementary rules of accident prevention

It is, therefore, necessary that whoever uses the machine read and respect the rules written below and the ones on the adhesive stickers of the machine.

1. Verify that on the machine are stuck all the security signs and that they are readable.
2. Before cleaning the machine, making any adjustments or reparations, turn off the tractor engine. Before each operation put the machine on the floor or on steady supports.
3. Never approach to the machine moving parts
4. La **MILL GRADER Mod. MTZ-MTZhi** has been manufactured for a specialized use. It must, therefore, always be in perfect working conditions and only R2 spare parts should be used when making any reparations.
5. Before using the machine, check the tightening of the nuts and screws, in particular those of the hoes and the three point-linkage.
6. Keep away all the people or animals before starting to work
7. Be careful when working alongside roads, pathways or sloping ground
8. Do not leave the machine working without supervision.
9. While checking or repairing the machine, be sure that nobody can start it up accidentally.
10. Wear tight-fitting clothes that do not cause any footholds in the rotating parts of the machine.
11. Do not climb on the machine at work
12. Do not interfere with objects on the machine while working.
13. Never use the machine without the back roller or without the protections delivered with the machine. Never remove the protections
14. In order to adjust the scraper, always turn off the tractor engine and make this operation safely.
15. In case the machine blocks, before making any reparations, turn off the tractor engine and remove the key
16. Always read the instruction booklet of the tractor before fitting and using the **R2** machine. Do not remove or evade the security systems of the tractor; before start working, be sure that the security systems of the tractor work correctly; if not, do not use the machine.
17. Do not carry people, animals or objects on the machine.
18. In case of road traffic respect the regulations in force in your country; put on the machine all the signals required; always verify the maximum weight allowed on the wheel axle. Pay attention: the road holding, the stability in cornering, and the tractor braking can result different because of the presence and position of the machine.
19. While fixing the cardan always follow the instructions given by the constructor. (the cardan's operation and maintenance manual) and the instructions illustrated in this booklet.
20. Be very careful while assembling the machine to the tractor.
21. The diameter of the machine pins for the tractor connection, must correspond to the balls of connection of the tractor.
22. Do not go near and do not allow anyone to approach in the area of the tractor lifting.



**6 - Components assembly and tractor coupling**  
(\*note 5 mod. hi)

Note: all the components that make part of the machine and that must be assembled before using it, have been designed to minimize the user's work; it is expected that the three-point linkage is assembled with universal screw wrenches or pneumatic wrenches; the cardan and the arms tractor connection are assembled manually.



The assembly must be made on a steady surface or on an homogeneous level floor. During the assembly wear leather gloves and accident-prevention shoes

If pneumatic wrenches are used, wear the ear protections.



**6.1 Three-point linkage frame assembly**

Fig. 5

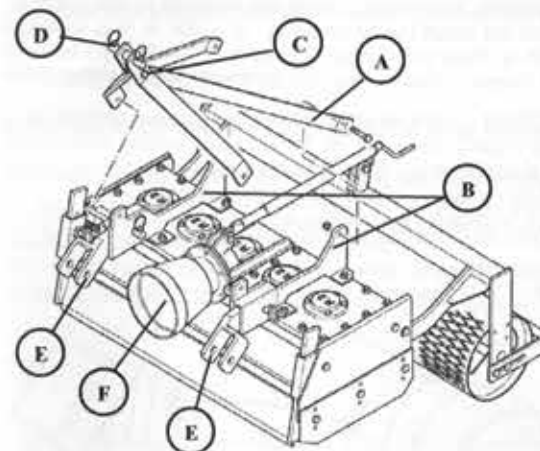

The three-point linkage frame (Fig. 5 - Rif. A) is supplied pre-assembled with the bolts and nuts pre-positioned. Assemble the frame to the supports (Fig. 5-Rif. B) as shown in figure (note: the elements that form the frame must be screwed to the external of the supports. Tighten the four screws frame connection three point and the three-point linkage screw (Fig. 5 - Rif. C) to 85 Nm.

Fit in the tractor connection arm (Fig. 5 - Rif. E) in the supports seats (Fig. 5 Rif - B); fit in the security pins.

- A - Three-point linkage frame
- B - Supports
- C - Three-point linkage
- D - Three-point linkage connection pin
- E - Arms linkage lifting tractor
- F - Pignon

**6.2 Tractor hooking**

Put the two parallel arms of the tractor coupling (Fig. 6 - Rif. A) in the oscillating arms (Fig. 6 - Rif. B) of the MILL GRADER.

Connect the tractor three-point linkage (Fig. 7 Rif. A) adjusting the MILL GRADER in order that you will get the best working position.

Fig. 6



Fig. 7

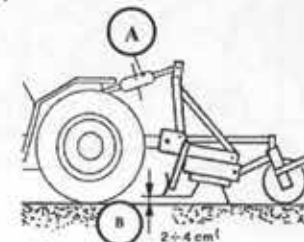

Pull the chains of the lifting arms so that the machine does not oscillate across.

6.3 – Cardan shaft connection

Once the machine has been fitted on to the tractor, verify the exact length of the cardan shaft. For a safety function of the cardan shaft, it is very important to check that in the different working positions the drive hoses fit in half of their length and never less than 1/3 of their length (Fig.8); repeat this control when the **MILL GRADER** when it is fitted to another tractor.

When fitting the cardan shaft, be sure that the bolt or push-button on both sides are well locked (Fig.9 - Ref.A).

Lock the cardan protections with the suitable chain to avoid them from turning during the motion drive (Fig. 10).

To reduce the cardan wear ( and increase the length of life) limit the working angle maximum to 15° (fig. 11).

**Read carefully the cardan instruction booklet before the connection.** Make the operations wearing appropriate protective devices for each person.



-It is forbidden to use the cardan without the protections It is necessary to replace the cardan protections once they are worn out.

- In order that the cardan and their components last longer, when the machine is not working , anchor the cardan to the hook so that it does not touch the ground (Fig. 12 – Ref. A. It is expected that the **MILL GRADER MTZ** is used with a shear bolt torque limiter(Fig. 13 – Ref. A) to avoid mechanical overloads in case the machine blocks . The cardan must be connected with the clutch from the side of the **MILL GRADER** .

Cardan type: CE type 4 for nominal horse-power up to 35 HP at 540 r.p.m. with shear bolt torque limiter M8x50 DIN 931 – 8.8.

The use of cardans with different characteristics than the ones supplied and the use of shear bolt torque limiters different from the ones indicated , excludes the **GUARANTEE** automatically.

**ALWAYS USE CARDANI CE CARDANS AND IN PERFECT STATE F REPAIR.**

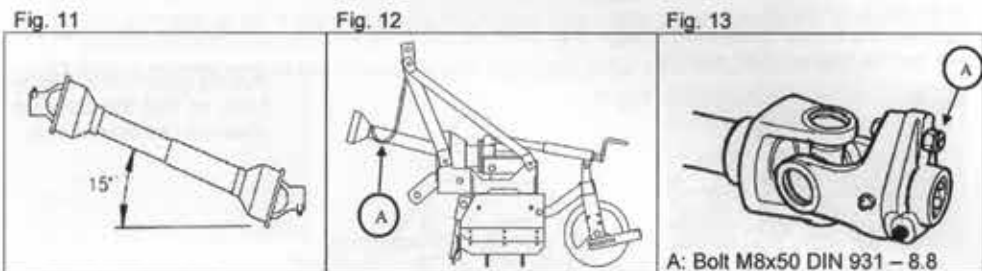
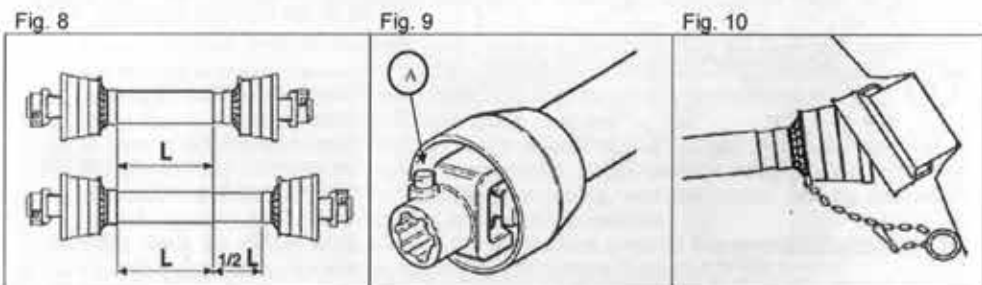

7 - Preparation for use



Before using the machine it is necessary to perform the following controls with the tractor or tractor off and the key off:

- Check that the lubricant is at the indicated level.
- Check the bolts tightening and that all the elements are in perfect conditions.
- Check that the signs security are present and legible.

8 – Working depth adjustment

(\*note 6 mod. hi)

The working depth is adjusted by the screw crank register roller ( (Fig.14 - Ref.A);

In order to prevent the hoes from remaining exposed and to avoid any dangerous situation during the milling, it is important the the extension sides (Fig. 14 – Ref. D) are adjusted in such a way that they always touch the soil. The extension sides adjustment must be made with the walking tractor or the tractor off and the key off.



The extension sides adjustment must be made with the walking tractor or the tractor off and the key off.

9 – Levelling adjustment

The levelling is made with the front shovel (Fig.6 - Ref.C); the scraper is adjusted manually with the two special screws and depends on the working depth chosen (Fig.14 - Ref.C). For a good levelling result, be sure that while working there is always earth in front of the scraper.

In order to prevent the hoes from remaining exposed and to avoid any dangerous situation during the milling, it is important that the scraper is adjusted in a way that it touches lightly the soil surface.



Adjust the scaper always with the tractor off and the key off. Wear protective gloves to prevent injury to the skin of the hands.



Fig. 14

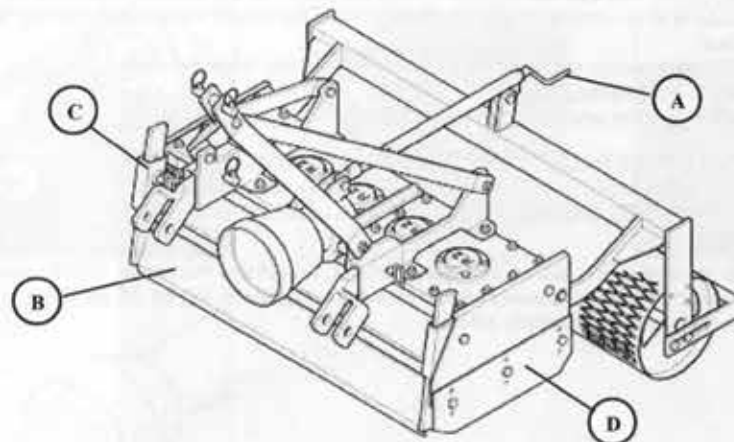

**10 – Machine use**  
(\*note 7 mod. hl)

**10.1 – Soil working**

Once you have made the adjustments, it is possible to operate the tractor and so the PTO that will determinate the hoes rotation . Pressing the forward, the working soil will start. The operator's position is at the driver's tractor seat

It is important to remember that while driving you should not make any turning maneuvers (the hoes are inserted into the ground) but only small corrections of direction.

To change direction do as follows:

1. Stop the motion of the tractor feed.
2. Stop the PTO motion.
3. Lift the machine using the tractor lift group.
4. In order to change direction, place yourself in the track you would like to follow.
5. Lower the machine
6. Operate again the PTO motion.
7. Operate again the forward motion.



Keep in mind the rules for the prevention of accidents mentioned in Section 5.  
5. Always remember to

- Keep away people or animals from the working area; do not allow anyone to approach to the machine while working.

- Never approach to the mechanical moving parts; wear safety shoes. If while working, there is a lot of dust (which will depend on the type of soil) wear a dust mask

- Do not use the machine in reverse; do not use the machine on steep slopes (verify the tractor instruction booklet).

- Before operating the machine, verify that the safety system of the tractor functions correctly.



**10.2 – Power harrow locking**

The MILL GRADER Mod. MTZ has been designed and constructed so as to minimize the possibility that the mill grader can lock while working.

It is not excluded, however, that this can happen if there are stones or big stones, iron wires or other elements that can fit in or roll in the hoes. In order to avoid the power harrow from locking, we advise to do as follows:

- Before starting to work, remove the big stones, the iron wires, etc. from the surface .
- Adjust the working depth needed.

Replace the hoes when they are worn out (see paragraph12)



**If the power harrow locks, before making any adjustment, TURN OFF THE TRACTOR ENGINE and REMOVE THE KEY. The key must be kept by the person that will remove the stuff that has locked the machine**



To unlock it, remove the stuff with a tool of lengthened shape; do not use the hands. NOTE: usually the machine is unlocked when the walking tractor or tractor engine is turned off as there is no pressure in the hoes that keep the blocking piece

**11 - Maintenance**  
(\*note 8 mod. hl)

Operations to be carried out in order to maintain the machine in good working conditions:

- Before using the machine:

1. Check the screws tightening of the three-point linkage frame and the good state of repair of the pins and the safety pins of the connection arms.
2. Check that the screws are tight, in particular check that the hoes screws are intact, if while working they break, it is necessary to stop working and replace them.
3. Check the level of the lubricant oil in the gear-box (only in the models **MTZ 135-150-170-190**) through the transparent cap put on gear box side (Fig. 15 – Ref. A); the quantity of oil is enough if it is visible through the cap. If you need to fill oil up, use the cap put on the upper part of the gear box (Fig. 15 – Ref. B).

- Regularly:

Lubricate the universal joint spider (Fig. 18 – Ref. A) and the other cardan elements as indicated in the instruction booklet, through the greasers.

- At the beginning of the working season:

1. Grease the roller supports (Fig. 16 - Ref. A).
2. Check the grease level in the tank using the specially provided cap (Fig. 17 – Ref. A); this must be made when the machine has worked for several minutes.



During the maintenance operations wear protective gloves; for the lubrication/greasing operations always wear nitrile gloves and protective glasses

If the maintenance is made on a raised plane (for example on a workbench), always wear safety shoes.

All the maintenance work must be performed with the tractor off and the key off.



Fig. 15

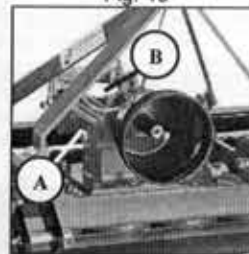

Fig. 16

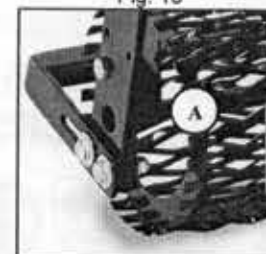

Fig. 17

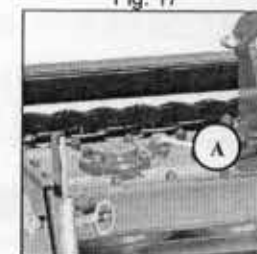
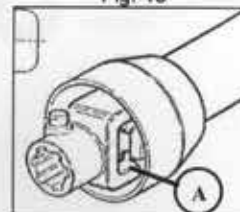

Fig. 18



After finishing the lubrication/greasing operations, clean the residual of lubricant left on the floor to avoid sliding.

## 12 - Hoes replacement

The hoes replacement must be made disassembling the roller group and placing the machine on the back side so that the hoes are parallel to the ground. Place the machine on a stable and safe plane. When mounting the new hoes, be sure that the clamping nut fits well in its seat (Fig. 19 Ref. B); It is necessary to use new nuts, bolts and washers each time the hoes are replaced. N.B. Use always original steel bolts. In order to use the hoes as much as possible, the machine has on the sides two extensions (Fig. 14 - Ref. D), this allows to work even if the hoes are worn out, the consumption must not exceed the 2/3 of the hoe itself.

Fig. 19

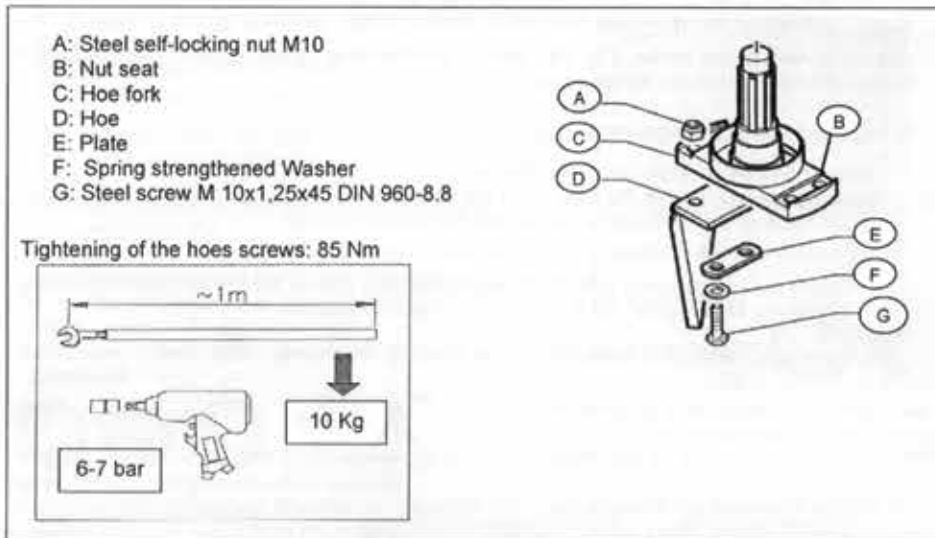

While replacing the hoes, wear protective gloves. If the maintenance is made on a raised plane, always wear safety shoes.

All the maintenance work must be made with the tractor off and the key off.

If the tightening of the hoes screws is made with pneumatic screwdrivers, put on ear protections and protective glasses.



## 13 End of work and storage of the machine -

If the **MILL GRADER Mod. MTZ-MTZhi** must remain unused for a long period, it is necessary to perform the following steps:

1. Wash thoroughly the machine and then dry it.
2. Check thoroughly the working of all the moving parts and replace the damaged, worn or deteriorated ones.
3. Check the tightening of all the bolts
4. Check the lubricant level in the main machine body (Fig. 17-Ref. A) and in the gear box (Fig. 15 Ref. A and B).
5. Protect and lubricate all the metal unpainted parts, then cover the machine and keep it in a dry place, it will be ready for use at any time.



**Attention:** Before using the machine again, refer to the "Maintenance" chapter.

Keep the machine in a way that people or animals do not run any risk (stumbling, machine falling down) and protect the prominent parts in order that they do not cause injury.

To avoid danger situations, store the machine in a way that does not hamper the escape routes, the emergency exits, fire protections (fire extinguishers, hydrants, etc.) and first aid (first aid boxes, etc.) from the storage place.

If the washing and/or cleaning of the machine is made by compressed air or water, be sure that there are no people or animals in the working area and wear protective glasses and if necessary a dust mask. Do not direct the jet of compressed air or water to people or animals.



## 14 - Scrapping and disposal of the components and packaging.

In case of machine scrapping it is necessary to make it unusable to prevent that others can use it again; the reuse of the machine by a third party, can be dangerous and accidents can be prosecuted according to Civil and Criminal Procedure, under the laws in force in your country towards those that get rid of the machine without precautions.

In order to make the machine unusable, it is necessary to disassemble the pinion-hub and dispose it separately from the rest of the machine

The machine is made of metal parts and of lubricant substances; they must be disposed in special waste disposal centers.

According to the type of transport, the machine can be packed in a cardboard (box) wood (pallet) plastic (polypropylene strapping and stretch film polyethylene) and metal (steel strapping seal or wire if the machine is delivered directly on a pallet); these items must be disposed in special waste disposal centers



The polyethylene stretch film must not be used as a children toy because it may cause suffocation



For the environment respect, dispose the materials in centers for separate collection of rubbish.

**Specific references for the hydraulic machines**

(\*note 1 mod. hi)

The power harrows MTZ hi have been designed to be applied to hydraulic machines which have an oil pressure between 150 and 180 bar.

- 1 - Register adjustment roller(screw crank)
- 2 - Register adjustment roller support
- 3 - Hydraulic motor

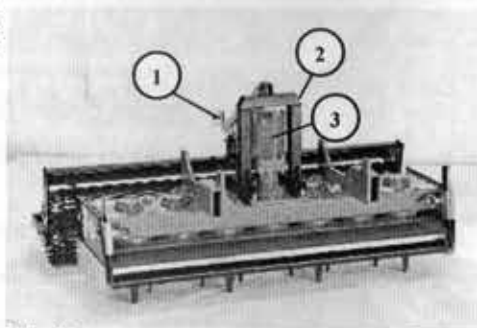

Fig. 20

(\*note 2 mod. hi)

	Model				
	MTZ 100 hi	MTZ 120 hi	MTZ 135 hi	MTZ 150 hi	MTZ 170 hi
Maximum height from the ground	70 cm	70 cm	70 cm	70 cm	70 cm
Oil pressure requested	150-180bar	150-180bar	150-180bar	150-180bar	150-180bar

Technical specifications of the hydraulic motor.

**NOTE:** the following data which concerns to the engine specifications are given by the manufacturer of the hydraulic motor; for the specifications of the engine application to the R2 machine look at the previous table and to the considerations of the following notes

Data	Value (Cont. Funct.)
Geometric displacement (cm <sup>3</sup> /rev.)	102
Max input pressure (bar)	210
Max operating pressure (bar)	175
Max torque (daNm)	26
Max flow (l/min)	75
Max rotating speed (rpm)	735
Max power (kw)	17
Max cont. Return pressure without drain line (bar) 0 + 100 rpm	75
Max cont. Return pressure without drain line (bar) 100 + 300 rpm	50
Max cont. Return pressure without drain line (bar) > 300 rpm.	25
Max return pressure with drain line (bar)	140
Max starting pressure with no load (bar)	12
Min. starting torque (daNm) at max. ΔP	21,5

(\*note 3 mod. hi)

The power harrows MTZhi can be lifted anchoring the lifting equipment to the frame Fig. 20 Ref. 2; pay attention to the machine inclination while lifting it.

(\*note 4 mod. hi)



For the hydraulic machines, it is important to consider the following rules to prevent accidents

- Caution: the hydraulic system is under pressure.
- Before connecting a hose to the hydraulic circuit of the tractor, be sure that the circuits side of the tractor and side of the machine are not under pressure.
- The pipe connections are protected by rubber stoppers, to prevent foreign bodies from entering. When the Mill Grader R2 is disconnected from the tractor, it is recommended to place the protective caps on the pipe fittings. When the Mill Grader R2 is connected to the tractor, the caps remain attached through a ring to the hoses, so that they can be repositioned next time.
- Check regularly the hydraulic hoses! If the damaged or worn out must be replaced immediately. The new ones must have the specifications and the quality required by the constructor(contact our technical service).
- If there is a leak, you must repair it immediately to avoid accidents.
- All the liquids under pressure, especially the hydraulic circuit oil, can cause serious skin accidents! In case of wounds, go immediately to the doctor: there can be risk of infection!
- **Before working on the hydraulic circuit, lower the machine, remove the pressure from the hydraulic circuit, stop the tractor and remove the key from the console.**
- In case of repair or work wear nitrite gloves and protective glasses.





(\*nota 5 mod. hi)

In this type of machines the tractor connection is supplied by the reseller. Address to the reseller for the assembly connection instructions of the Mill Grader R2-Tractor.

Fig. 21

Hydraulic circuit connection

A –  
G1/2" main ports thread depth 15 mm

B –  
G1/4" drain port thread depth 15 mm

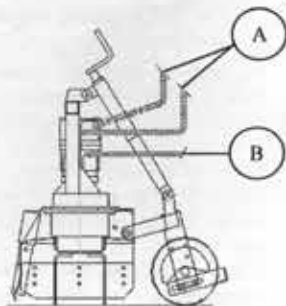

Screw the hoses to the engine and fit them through the quick coupling to the feed circuit and tractor drain (Fig.22).

Note: the Mill grader R2 can work in both sense of rotation.

Always wear gloves and protective glasses.



Fig. 22

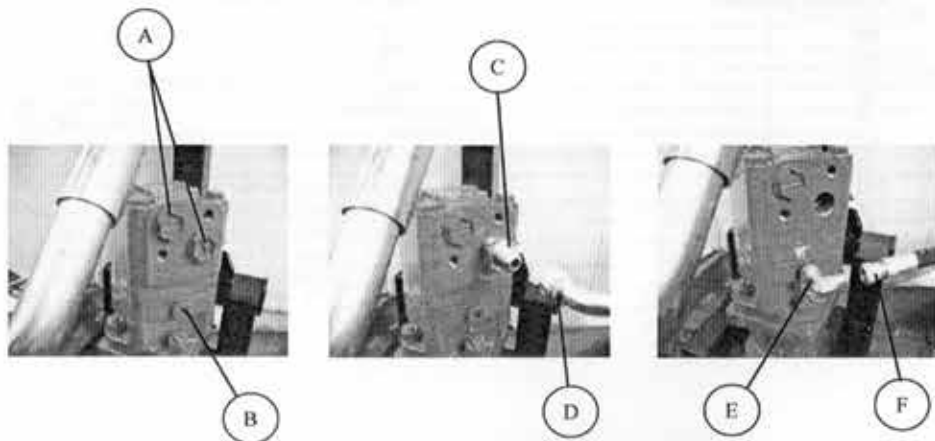

A: Main ports  
B: Drain port  
C: Pipe-connecting feed hose ( with sealingwasher)  
D: Pipe-connecting drain hose (with sealing washer)  
E: Drain hose

(\*note 6 mod. hi)

Adjust the working depth using the screw crank

(\*note 7 mod. hi) (\*nota 8 mod. hi)

General rules for the hydraulic motor use:

- Working oil temperatures in the hydraulic system should be kept between +30°C and +60°C. The anti-wear and lubrication properties of the oil are greatly reduced at higher temperatures.
- The ambient temperature around the engine should be between -30°C and +90°C
- Only use an oil containing antiwear additives ISO 46 or with a viscosity at normal operating temperature of approx. 37 cSt, it should also have an adequate viscosity index. Under no circumstances should oil viscosity be outside the range of 22 cSt to 75 cSt.
- Before starting the hydraulic system check oil level and firm mounting of all components.
- Run the system unloaded for 10+15 minutes to purge air from the circuit to prevent foaming and deviation.
- Check for leak, rectify and refill reservoir
- Check oil level regularly and clean filters or replace them according to filter manufacturers advice

For maximum life from motor oil contamination should never exceed the 20/16 (see ISO 4406). To ensure this level, return line filters should maintain 40 µm absolute or 25 µm nominal in open circuit, 20 µm absolute and 10 µm nominal in closed circuit.





**R2 S.a.s. di Rinaldi Roberto & C.**

Registered Office  
Via Valsellustra, 25-29  
40060 – Toscanella di Dozza  
Dozza – Bologna (ITALY)

Head office  
Via degli Artigiani, 23  
40024 – Castel San Pietro Terme  
Bologna (ITALY)  
Tel. (0039) 051.94.30.42  
Fax (0039) 051.69.42.086

[www.R2RINALDI.com](http://www.R2RINALDI.com)

[R2@R2RINALDI.com](mailto:R2@R2RINALDI.com)