

# SARRACENIA

130

Maintenance  
/ Repair  
/ Operating  
Hand Book







**MAINTENANCE-REPAIR AND OPERATING HAND BOOK**  
OPERATING MANUAL SPARE PARTS CATALOGUE





Dear Farmers;

It is important to complete the agricultural works and processes in time and as fast as possible. Performing higher-quality production in a shorter term is only possible through new and advanced production technologies.

In this sense, as DAMILANO GROUP we work on Modern agricultural machines in order to make your crops abundant and profitable.

As DAMILANO GROUP, which continuously make innovations and advancements for you to earn more while spending less effort, we are always at your side with our experience for more than a quarter century.

We always apply changes on our machines which we manufacture every year in accordance with technological developments of European firms and try to manufacture a better one than before.

## INDEX

---

<b>1. INTRODUCTION.....</b>	<b>7</b>
1a. Manual content.....	7
1b. Purpose of the instruction manual.....	7
1c. Keeping the instruction manual.....	8
1d. Warning symbols and their meanings.....	8
1e. Individual protective equipment.....	10
<b>2. GENERAL INFORMATION.....</b>	<b>10</b>
2a. Manufacturer identification data.....	10
2b. Description.....	12
2c. Technical data.....	12
<b>3. SAFETY.....</b>	<b>13</b>
3a. General warnings.....	13
3b. Safety during linkage to the tractor.....	15
3c. Safetyfield.....	16
3d. Safety after use.....	17
3e. Safety during maintenance.....	18
3f. Adverse field conditions.....	19
3g. Safety release devices.....	19
3h. Transport on public road.....	19
<b>4. OPERATION.....</b>	<b>20</b>
4a. Adjustment.....	20
4b. Connect the mower to the tractor.....	20
4c. Assembly of the PTO drive shaft.....	24
4d. Move the mower to the Transport position.....	25
4e. Move the mower to the Working position.....	28
4f. Stop the Tractor.....	32
4g. Disconnect the mower to the tractor.....	33
4h. Breakawayreset.....	34
4i. Breakaway adjustment.....	35

<b>5. MAINTENANCE.....</b>	<b>37</b>
5a. General maintenance.....	37
5b. Storage.....	37
5c. Lubrication.....	38
c1. Lubrication of mechanical components.....	38
c2. Lubrication of the centre gearbox.....	39
c3. Lubrication of overgear unit.....	39
5d. Knives.....	40
5e. Curtain replacement.....	41
5f. Disposal and scrapping.....	41
<b>6. WARRANTY.....</b>	<b>42</b>
6a. Exclusion from warranty.....	42
6b. Instructions.....	43
<b>7. PART LIST.....</b>	<b>45</b>

## 1. INTRODUCTION

### 1a. Manual Content

This operating manual is prepared for you to run and operate your machine correctly and properly and utilize from its specifications completely. You dispose any potential problems and maintain your machine for a long physical life by following the instructions in the operating manual.

This operator's manual is an integral part of the safe operation of this machine and must be maintained until at all times. **READ, UNDERSTAND, and FOLLOW**, the Safety and Operation Instruction contained in this manual before operating the equipment.

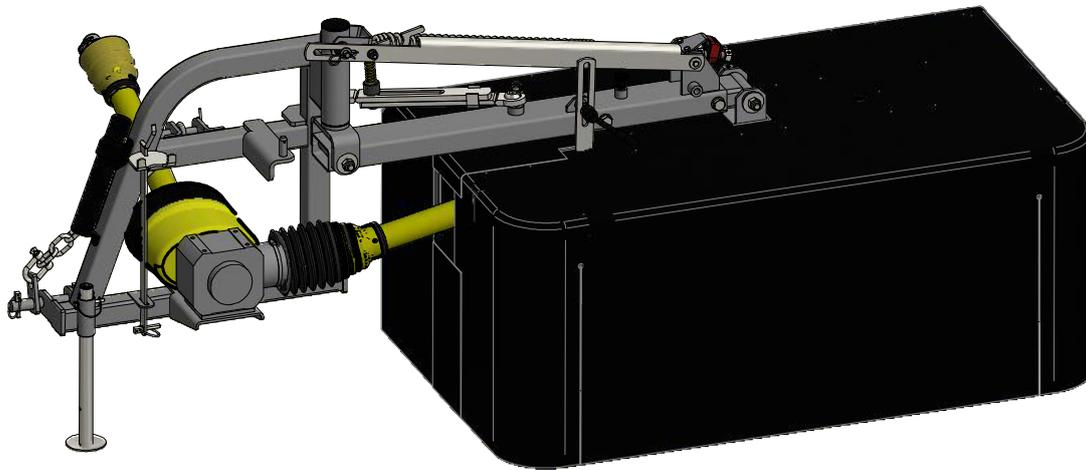

### 1b. Purpose of the instruction manual

This manual contains all the information necessary for a correct assemblage, use, operation and maintenance of the hoisting machine manufactured by DAMILANO GROUP.

These instructions provide a specific knowledge of the machine and of its features, of the necessary operations in order to identify and eliminate the most common defects and of the maintenance procedures. The illustrated spare parts catalogue allows identifying and procuring all the necessary spare parts to carry out the machine's scheduled and special maintenance.



The technical information contained in this manual is the property of DAMILANO GROUP and must be treated as confidential. It is therefore forbidden to divulge or to reproduce such data, even partially, without DAMILANO GROUP written authorization.

**1c. Keeping the instruction manual**

This manual should be kept in a good condition and should be stored in the proper manual canister so as to allow quick consultation whenever necessary.

**1d. Warning symbols and their meanings**

Particular symbols have been used in this manual to emphasize risks and/or dangerous situations as well as to catch the operator's attention on a particular operation or prescription. The same signs are placed directly on the implement.

**THE SIGNAGE IN THE MAINTENANCE, REPAIR AND OPERATING HAND BOOK AND THEIR MEANINGS :**

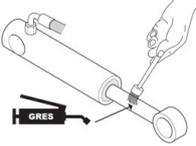
 Attention	 20 Km/h Speed Limit	 Important and Considerable Point
 While Pulling the Machine by a Tractor Nothing Can be Loaded or Pulled by the Machine	 It is Dangerous and Forbidden for Machines Wider than 3 Meters to be on any Highway	 Please, Check Whether There is any Loose Bolts or Nuts, if any Please Tighten
 Please, Lubricate any Grease Nipples	 Please, Lubricate by Using Thin Oil	 If, the Machine Will Not Run for a Long Time, Please Lubricate the Hydraulic Lift Shafts

## THE SIGNAGE ON THE MACHINE AND THEIR MEANINGS



Read the Maintenance Book Before Running the Machine.



Always Stop the Engine Before any Maintenance.



Do not stand between the Machine and Tractor while they are connected.



Do not come close to turning parts, they can cut your hand.



It is dangerous and forbidden to get on the machine.



Thrown object hazard, do not approach the machine. Keep a safe of at least 50 meters from the machine.



Risk of injury, wait until the machine has completely stoppe before approaching.



Crushing and shearing hazard. Keep hands away and stand clear. Keep a safe distance.



Serious accidents and injuries can result from operating this equipment at high speeds.



Keep away from the danger zone when switching mower from transport mode to field mode.



Keep away from rotating elements to prevent serious injury or death.



Please, lift and lower the machine only through these point.



CE Mark

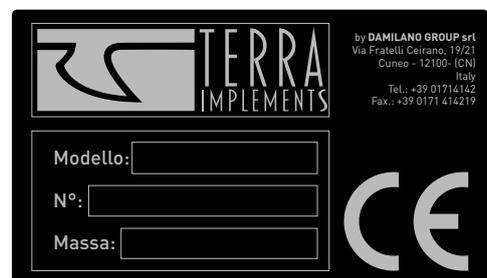

The Product Detail and Factory Introduction Label

### 1e. Individual protective equipment

During operation, maintenance, repairing, driving or storing of the machine, the operator shall wear safety shoes, safety gloves, and, if necessary, earplugs, dust mask and safety glasses.



## 2. GENERAL INFORMATION

### 2a. Manufacturer identification data



Damilano Group S.r.l.  
Division: Terra Implements  
Via Fratelli Ceirano, 19/21 Madonna dell'Olmo - Cuneo - Italy  
Tel.: +39 0171 4142  
Fax.: +39 0171 414219  
[www.terra-implements.it](http://www.terra-implements.it)



## 2b. Description

Your Mower is designed for light-duty cutting such as pasture mowing, weed and grass control. With a reasonable amount of preventive maintenance, your Mower will provide years of dependable service.



Any other type of use is considered as contrary to the intended use, therefore the manufacturer accepts no liability for any damage resulting from this misuse. Any risks resulting from non-intended use must be born solely by the user.



Never allow children to play on or around Tractor or Implement. Children can slip or fall off the equipment and be injured or killed. Children can cause the Implement to shift or fall crushing themselves or others.

## 2c. Technical Data

SARRACENIA		130
Requested power	HP	18/25
Max. speed of PTO shaft	r.p.m.	540
Drums	N.	2
N blade for drum	N.	4
Weight	Kg.	320

## 3. SAFETY

### 3a. General Warnings



The first section of this manual includes a list of Safety Messages that, if followed, will help protect the operator and bystanders from injury or death. Read and understand these Safety Messages before assembling, operating or servicing this Implement. This equipment should only be operated by those persons who have read the manual, who are responsible and trained, and who know how to do so responsibly.

- Read and follow all the warning and instruction decals placed on the machine, as an additional safety guarantee. All the decals placed on the machine are shown in this manual with an explanation of their function 
- Keep the manual handy to check operational running. If the manual becomes lost or damaged, order a copy from Terra-implements.
- Avoid wearing loose clothing. The operator must wear clothing that is as tight-fitting as possible.
- Always keep the machine in excellent condition in order to avoid the risk of accidents.
- Before starting up the machine always check that there is nobody (or children) in the vicinity. Always ensure adequate visibility.
- Carrying people or other things on the machine is strictly forbidden. 
- Always connect the mower correctly to the tractor to ensure adequate stability.
- Observe the highway code as regards transport dimensions. Check the road transportation equipment such as signaling panels, light and check all the protective casing.
- The remote controlled devices (ropes, chains, etc.) must be positioned in such a way that they do not trigger any unintentional operation in any working on transportation stages.
- Take care to avoid sharp turns. On bends pay attention to the articulated three point linkage of the mower that must always be fixed to the relative bracket.
- Beware of the risk of pinching on the opening or closing of the external rotors, carefully follow the instructions indicated in this manual.
- Warning, no person must be allowed to stand or move between the tractor and the machine.
- This implement may be wider than the Tractor. Be careful when operating or transporting this equipment to prevent the Implement from running into or striking sign posts, guard rails, concrete abutments or other solid objects. Such an impact could cause the Implement and Tractor to pivot violently resulting in loss of steering control, serious injury, or even death. Never allow the Implement to contact obstacles.
- Be careful when transporting the Implement using the tractor. Turn curves or go up or down hills only at a low speed. Slow down on rough or uneven surfaces.



Practice all usual and customary safe working precautions and above all remember safety is up to YOU. Only YOU can prevent serious injury or death from unsafe practices.

- Make sure the Tractor steering and brakes are in good condition and operate properly. Before transporting the Tractor and Implement, determine the proper transport speeds for you and the equipment.
- Test the appliance at low speeds when cornering, to prevent it from turning over. When operating in traffic always use flashing warning lights of the tractor and reduce speed. Be aware of the traffic around you. 
- Be particularly careful when transporting the Implement using the tractor. Turn curves or go up or down hills only at a low speed and at a gradual steering angle. Make certain that at least 20% of the tractor's weight is on the front wheels to maintain safe steering. Slow down on rough or uneven surfaces. 
- Do not put hands or feet under mower decks. Blade Contact can result in serious injury or even death. Stay away until all motion has stopped and the decks are securely blocked up. 
- Do Not operate this equipment in areas where insects such as bees may attack you and/or cause you to lose control of the equipment. If you must enter in such areas, use a tractor with an enclosed Cab and close the windows to prevent insects from entering. If a tractor cab is not available, wear suitable clothing including head, face, and hand protection to shield you from the insects. Attacking insects can cause you to lose control of the tractor, which can result in serious injury or death to you or bystanders.
- The blades could fail upon impact with heavy, solid objects such as metal guard rails and concrete structures. To reduce the possibility of property damage, serious injury, or even death, never allow the cutting blades to contact such obstacles.
- The Blades of this Mower can throw objects if shields are not properly installed and maintained. Serious injury or even death may occur unless care is taken to insure the safety of the operator, bystanders, or passersby in the area. 
- Do not let the Blades turn when the Mower Deck is raised for any reason, including clearance or for turning. Raising the Mower deck exposes the Cutting Blades which creates a potentially serious hazard and could cause serious injury or even death from objects thrown from the Blades. 

## 3b. Safety during linkage to the tractor



Make sure there are no persons (or children) near the mower or tractor when you connect it to the tractor. Make sure the front axle weight of the tractor is sufficient and that you do not overload the mower when it is in transport position.

- The operator and all support personnel should wear hard hats, safety shoes, safety glasses, and proper hearing protection at all times for protection from injury including injury from items that may be thrown by the equipment.
- Pinching and crushing hazard when bringing the to the transport and working position. Operate with the machine more carefully and keep others away from the area.
- Caution: do not stand between the tractor and the machine. Do not stand in the operational vicinity of the machine. 
- During transportation with the machine raised, always make sure that the control lever is locked in order to avoid accidental lowering of the machine.
- Use only drive shafts recommended by the manufacturer. Always make sure that the drive shaft guards are in good condition.
- Stop the engine and remove the ignition key and disengage the PTO before attaching or detaching the universal drive shaft. Always make sure that the drive shaft is correctly installed and perfectly secured. Prevent the rotation of the guards by using the chains provided.
- In the event of the use of a universal drive shaft complete with overload or freewheeling clutch it must always be installed at the machine end.
- Before engaging the universal drive shaft, make sure that the speed and the rotation of the PTO is compatible with the machine.
- Before engaging the PTO shaft ensure that everybody is clear of the machine.
- When the PTO is operation NOBODY must be in the vicinity of the universal drive shaft and the mower. Never engage the PTO shaft when the tractor engine is switched off. Always disengage the PTO when the bend angle is critical. Operation to always be undertaken with the engine off and the main switch key (ignition key) removed.
- Make sure that there are not any foreign bodies in the machine (debris, tools, etc.) which could affect operation or cause injuries to the operator.

### 3c. Safety field

- Start tractor only when properly seated in the Tractor seat. Starting a tractor in gear can result in injury or death.
- NEVER use drugs or alcohol immediately before or while operating the Tractor and Implement. Drugs and alcohol will affect an operator's alertness and coordination and therefore affect the operator's ability to operate the equipment safely. NEVER knowingly allow anyone to operate this equipment when their alertness or coordination is impaired. Serious injury or death to the operator or others could result if the operator is under the influence of drugs or alcohol. 
- While working makes sure that no people or animals are within 50 m of the machine. When working near public roads or public places keep others away and be more careful. 
- Learn how to stop the tractor engine suddenly in an emergency. Never allow inexperienced or untrained personnel to operate the Tractor or Implement without supervision.



**PROLONGED EXPOSURE TO LOUD NOISE MAY CAUSE PERMANENT HEARING LOSS!** Tractors with or without an Implement attached can often be noisy enough to cause permanent hearing loss. We recommend that you always wear hearing protection if the noise in the Operator's position exceeds 80db. Noise over 85db over an extended period of time will cause severe hearing loss. Noise over 90db adjacent to the Operator over an extended period of time will cause permanent or total hearing loss.

- Do not mow with two machines in the same area except with Cab tractors with the windows closed.
- Make sure the PTO shield, integral driveline shields, and input shields are installed when using PTO-driven equipment. Always replace any shield if it is damaged or missing. 
- Pinching and crushing hazard when bringing the machine to the transport and working position. Operate with the machine more carefully and keep others away from the area. 

## 3d. Safety after use

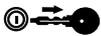
- Before leaving the tractor shut off the engine by removing the main switch key  (ignition key).
- Do not mount or dismount the Tractor while the tractor is moving. Mount the Tractor only when the Tractor and all moving parts are completely stopped.
- Prolonged operation may cause operator boredom and fatigue affecting safe operation. Take scheduled work breaks to help prevent these potentially impaired operating conditions.
- Never leave the Tractor and Implement unattended while the Implement is in the lifted position. Accidental operation of lifting lever may cause sudden drop of unit with injury or death by crushing.
- Do not operate this equipment in areas where insects such as bees may attack you and/or cause you to lose control of the equipment. If you must enter in such areas, use a tractor with an enclosed Cab and close the windows to prevent insects from entering.
- If the machine is not used for a long period it is necessary to store it inside to avoid exposure to weather and dust. Before operating it again, it is good practice to clean the machine and lubricate all mechanical components to prevent rust.
- Clean the machine thoroughly.
- Inspect the machine for damaged parts and scratched paint.
- Make sure that safety signs are legible and located properly on the machine.
- Replace damaged safety labels.
- Replace damaged or worn curtain.
- Lubricate all mechanical components, locking pins, the coupling head to the cardan joint.
- Replace oil in the gearbox and in the cutter bar following the instructions.
- If possible, store the machine in an enclosed place.

### 3e. Safety during maintenance

- Before maintenance, adjustment or cleaning, lower the machine to the ground, turn off the engine of the tractor, disengage power takeoff, set hand brake and remove the ignition key.
- Never attempt to clean, lubricate, repair, or adjust the universal drive shaft, unless the PTO shaft has been disengaged, the engine has been switched off and the main switch key has been removed.
- Once the universal drive shaft has been disengaged replace to PTO shaft guard.
- The machine must never be operated with a damaged or defective universal drive shaft.
- Always follow the instructions provided by the universal drive shaft manufacturer.
- Always read carefully and comply fully with the manufacturer's instructions when handling oil, solvents, cleansers, and any other chemical agent.
- **KEEP AWAY FROM ROTATING ELEMENTS** to prevent entanglement and possible serious injury or death. 
- Use a ladder or raised stand to access high spots which cannot be reached from ground level. Slipping and falling can cause serious injury or death.
- Use gloves and eye protection when servicing hot components. Contact with a hot surface or fluid can cause serious injury from burns or scalding.
- Always maintain the safety signs in good readable condition. If the safety signs are missing, damaged, or unreadable, obtain and install replacement safety signs immediately.
- Do not modify or alter this Implement. Do not permit anyone to modify or alter this Implement, any of its components or any Implement function.
- Never attempt to lubricate, adjust, or remove material from the Implement while it is in motion or while tractor engine is running.
- Always read carefully and comply fully with the manufacturer's instructions when handling oil, solvents, cleansers, and any other chemical agent. 
- Never work under the Implement, the framework, or any lifted component unless the Implement is securely supported or blocked up to prevent sudden or inadvertent falling which could cause serious injury or even death.

### 3f. Adverse field conditions

This section illustrates the main adverse field conditions when using the mower:

- Make sure that there are not any stones or rocks on the ground (diameter over 8-12 cm).
- Make sure that there are not any stumps higher than 10 cm and diameter over 8-12 cm.
- Make sure that there are not any metal elements on the ground, such as nets, cables, ropes, chains, pipes etc.
- Follow recommendations for height adjustment and make sure that no one is within 50 m of the mower.
- It is recommended not to work with the machine fully lowered to the ground in wet grass conditions to avoid damaging crop and affecting performance of the machine.

### 3g. Safety release device

If an obstacle is hit the safety release device allows the cutter bar to swing back, thus providing shock absorption.

- Stop engine and disengage power takeoff of the tractor.
- Reverse the tractor for 2 meters.
- Reinstalling the safety device.
- Before resuming operation check adjustment of the safety release device make sure that cutter components have not been damaged.

### 3h. Transport on public roads



**Comply with the existing traffic regulations.**  
**If tractor lights visibility is blocked by the towed machine, use detachable warning boards with lighting equipment for adequate warning to other vehicles.**

When driving on public roads, use flashing warnings lights on the tractor day and night.

Should the rear overhang exceed 90% of the tractor's length, a specific authorisation for "special vehicles" may be required.

When driving on public roads, in addition to traffic regulations, follow instructions noted on the tractor licence and select a safe speed especially when transporting drawn machines or when travelling over rough or hilly terrain.

Before travelling on public roads after operation, clean debris from tyres and moving parts.

## 4. OPERATION

### 4a. Adjustments

Before operating the machine make the necessary adjustments.

Correct adjustment of the machine ensures proper operation of the machine, and helps improve performance.

- In order to reduce the load of the machine on the ground and to be parallel to the ground adjust spring tension using their corresponding bolts. **(Point D Figure1).**
- In general quality of mowing and power requirement depend upon:
  - Kind of product to be mowed;
  - Type of knives used;
  - Working height;
  - Speed of the Tractor.

### 4b. Connect the mower to the tractor

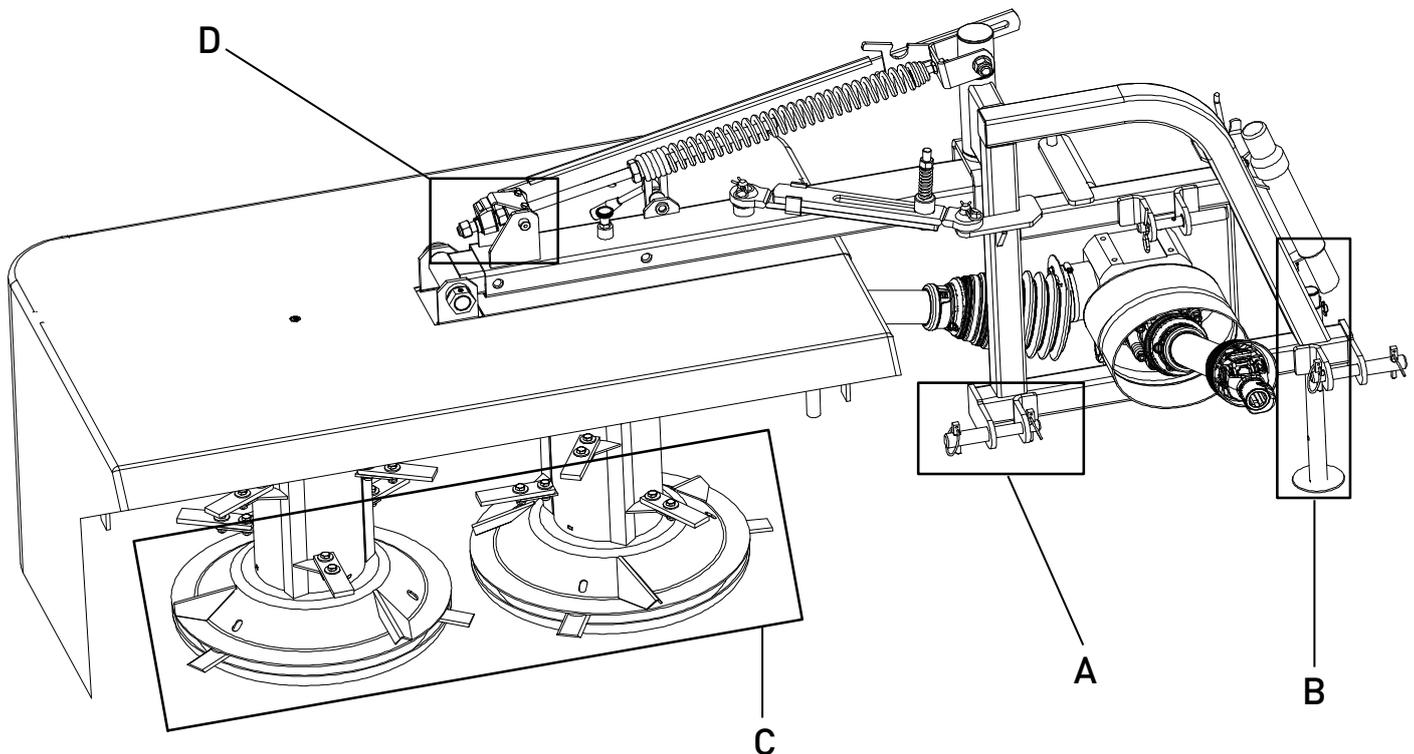

Figure 1 Sarracenia 130.



Make sure there are no persons near the mower when you connect it to the tractor. Nobody shall be within 5 metres of hitching point.

Make sure the front axle weight of the tractor is enough (use front weights if necessary) and that you do not overload it with the mower when it is in the transport position.



Make sure that the control lever is properly positioned as to avoid unintentional raising or lowering of the mower.

The area shall be properly lightened under conditions of reduced visibility.

#### Procedure:

1. Approach the tractor to the mower until the lifting bars and the three point linkage are lined up and connect them with the pins.
2. Rotate the shear pins to Cat. I or Cat. II depending on your tractor type. Connect the lifting bars of the tractor to the shear pins. **(Point A Figure 1)**

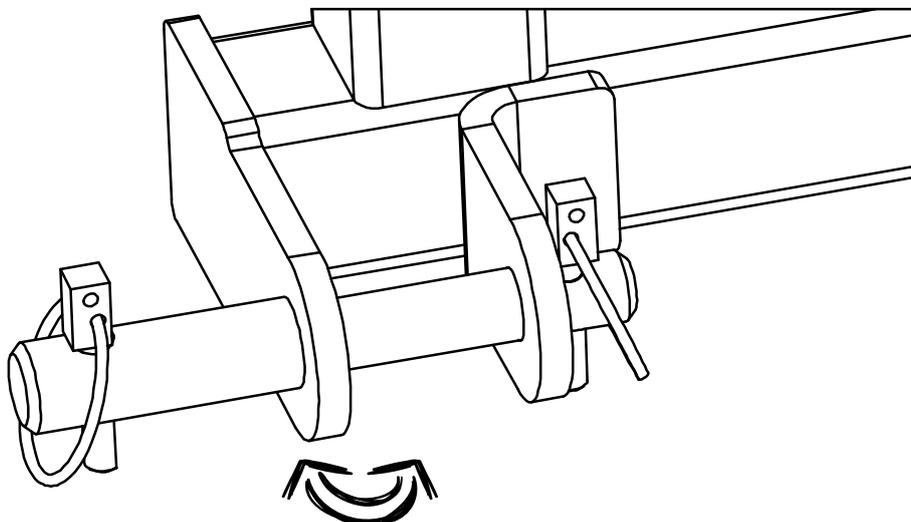

3. Lift the stand of the machine. **(Point B Figure 1)**

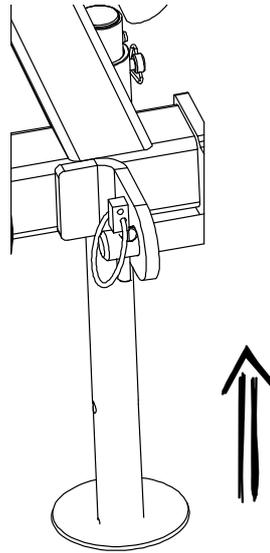

4. Connect the three point to the upper hitch link and adjust length so that the mower is parallel to the ground. **(Point C Figure 1)**

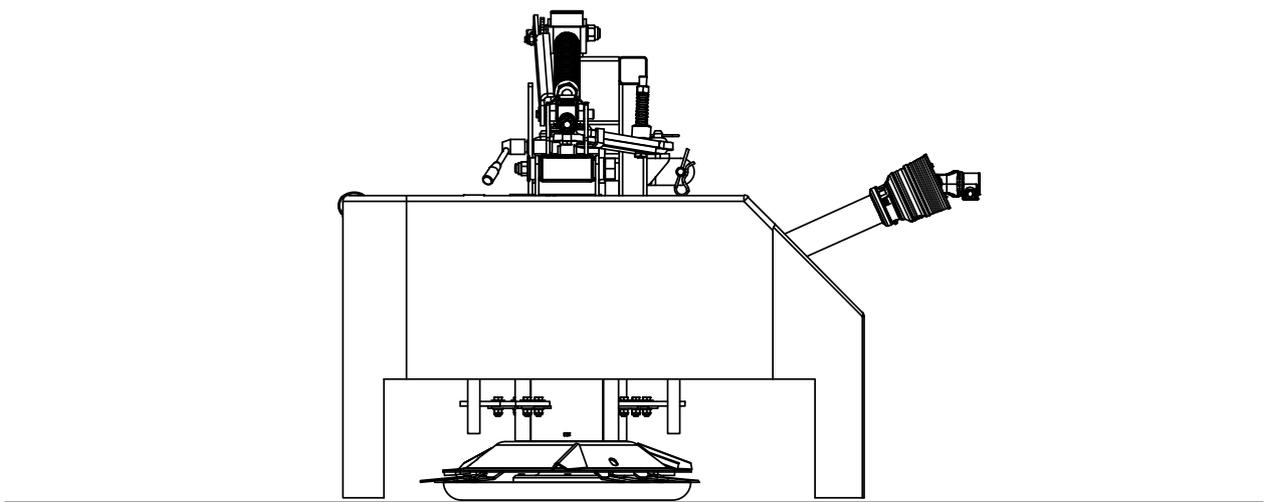

5. Adjust the tension of the spring to the value of 95,00 (Big tractor). **(Point D Figure 1)**

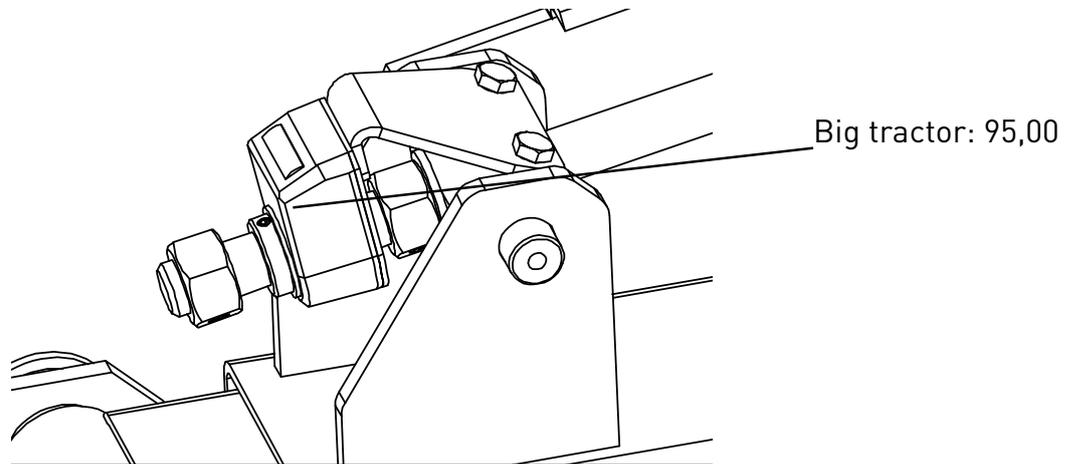

6. Connect the chain to the tractor **(Point A)** to maintain the correct lower position at the end of the field and connect the PTO.

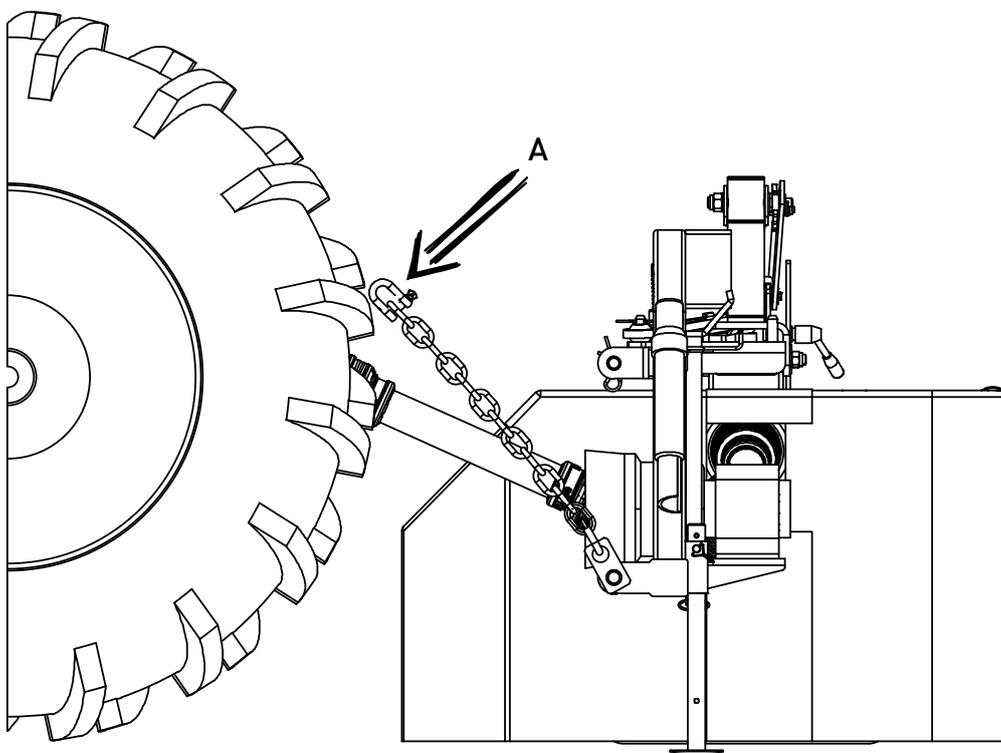

#### 4c. Assembly of the PTO drive shaft



Before performing any operation stop engine and remove the key.

After attaching the machine to the tractor, connect the PTO drive shaft to the power takeoff of the tractor.

If you use a different drive shaft type than the one supplied with the machine, make sure that the covers of the machine and the tractors overlap by at least 5 cm in compliance with existing law.

- Clean and lubricate the power takeoff.
- Lubricate on a regular basis the drive shaft.
- Follow assembly instructions given by the manufacturer.
- Hang chains to avoid rotation.
- Make sure that the safety locking device is properly installed and secured.
- NEVER operate the machine with a PTO shaft angle larger than 35° for a long time.  
**(Figure 2)**

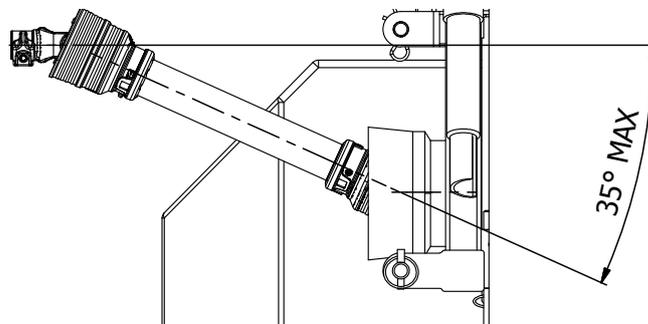

**Figure 2** PTO shaft angle.

Connect the drive shaft last to the power takeoff and detach it first after operation.

Use exclusively drive shafts with EC mark to ensure proper operation of the machine.

Use only drive shafts with all safety guards in good conditions.

The length of the drive shaft shall be adapted to the tractor.

WHENEVER the drive shaft is disengaged from the power takeoff of the tractor place it on its support leg.

**Terra Implements is not liable for any damages resulting from misuse and improper assembly of the drive shaft.**

In addition to the drive shaft – which is provided with a clutch to avoid damage to the machine in case of collision with obstacles – drum mowers are equipped with an overrunning clutch drive shaft.

## 4d. Move the mower to the Transport position



Make sure there are no persons close to the tractor when you move the mower to the transport position.

Make sure the front axle weight of the tractor is sufficient (use front weights if necessary) and that you do not exceed the permitted axle load when the Mower is in the transport position.

Use all light and warning signals as defined by your local road traffic regulations.

Procedure :

1. Remove the safety R-pins from the safety release bar.

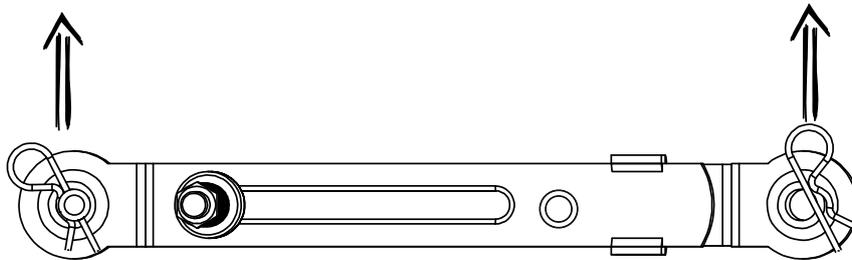

2. Remove completely the safety release bar from both the pins.

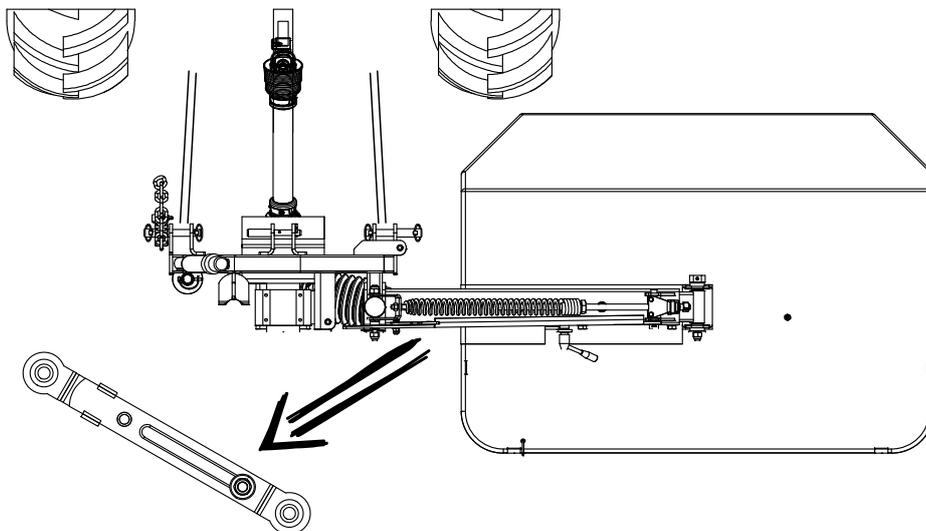

3. Rotate the mower until the locking pivots fit into the holes.

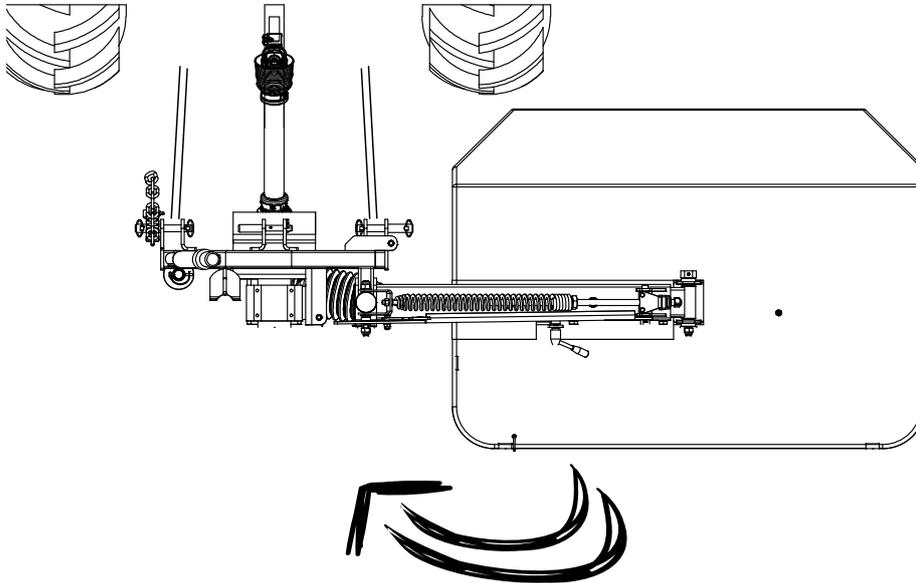

4. Position the breakaway system to the pivots on the machine's frame paying attention to put the intermediate hole of the bar on the transport pin of the frame as shown in the **(Point B)**.

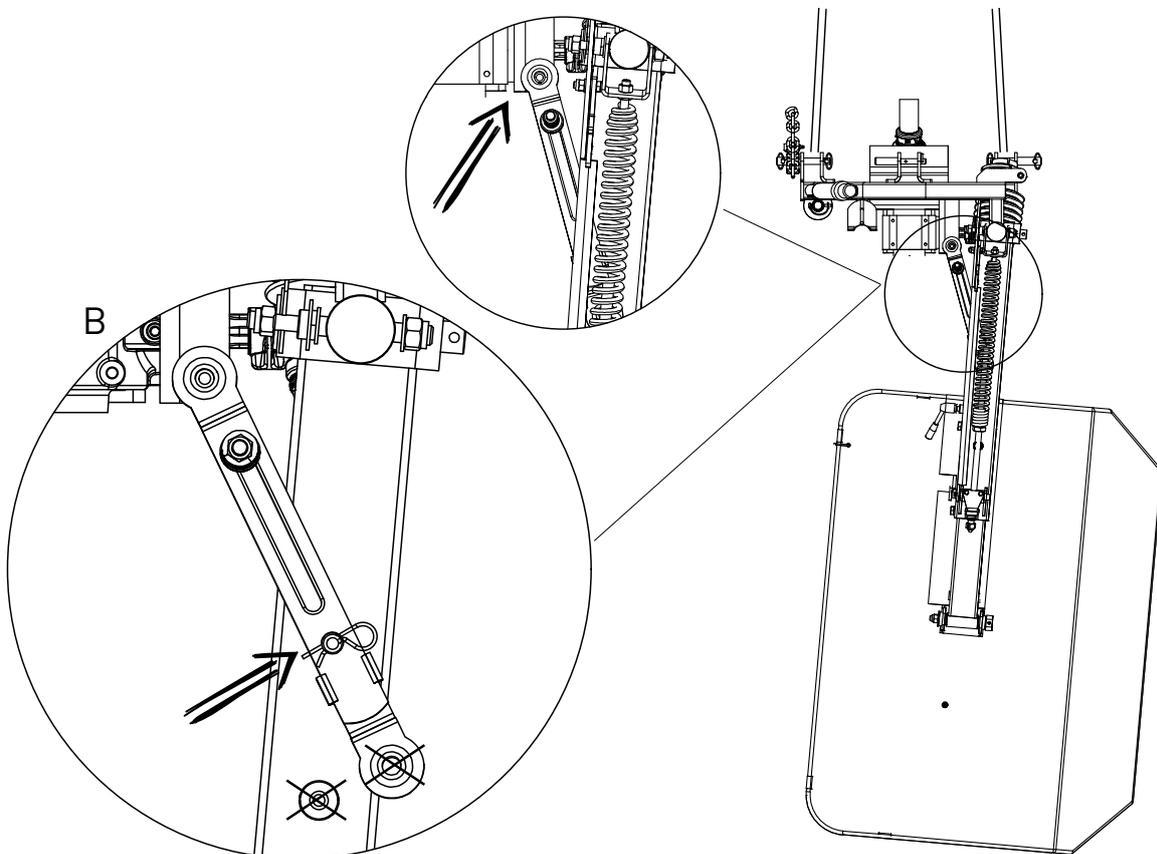

5. Insert the safety R-pins in the pins of safety release bar.

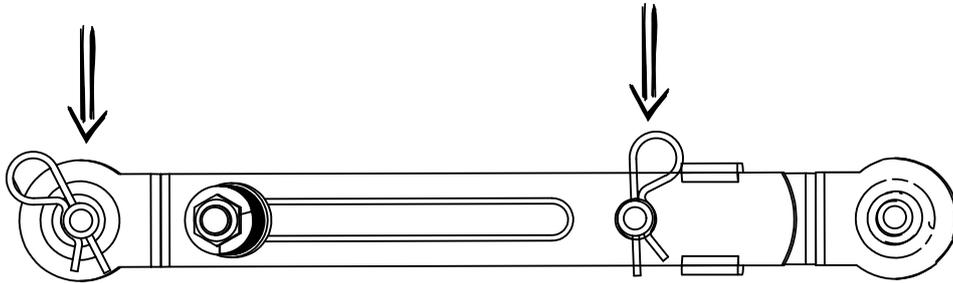

6. Move the plate-hook in the position shown in **(point A)**.
7. Screw and block the adjustable handle as shown in **(point B)**.

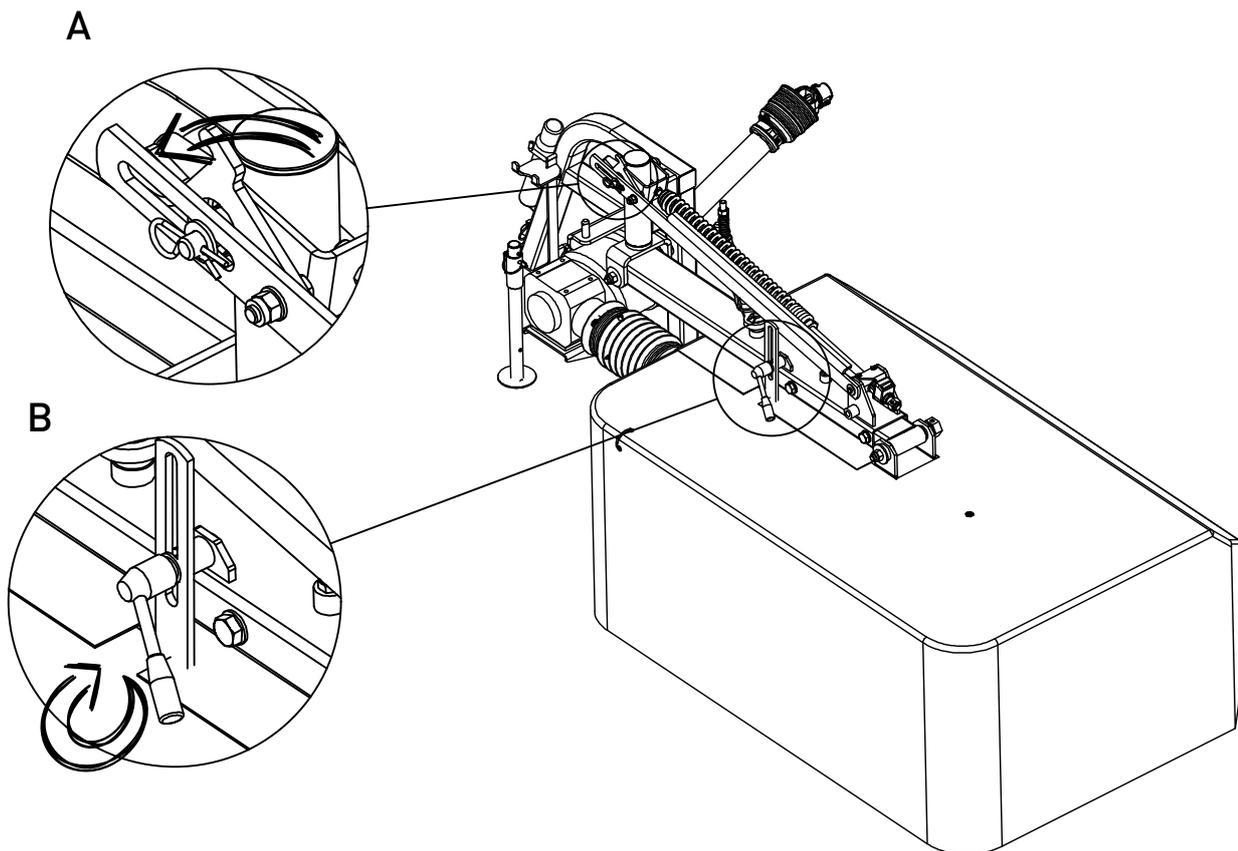

9. Raise the mower.

#### 4e. Move the mower to the Working position



Make sure there are no persons close to the tractor when you move the mower.

Procedure :

1. Screw and unlock the adjustable handle as shown in **(Point B)**.
2. Move the plate-hook in the position shown in **(Point A)**.

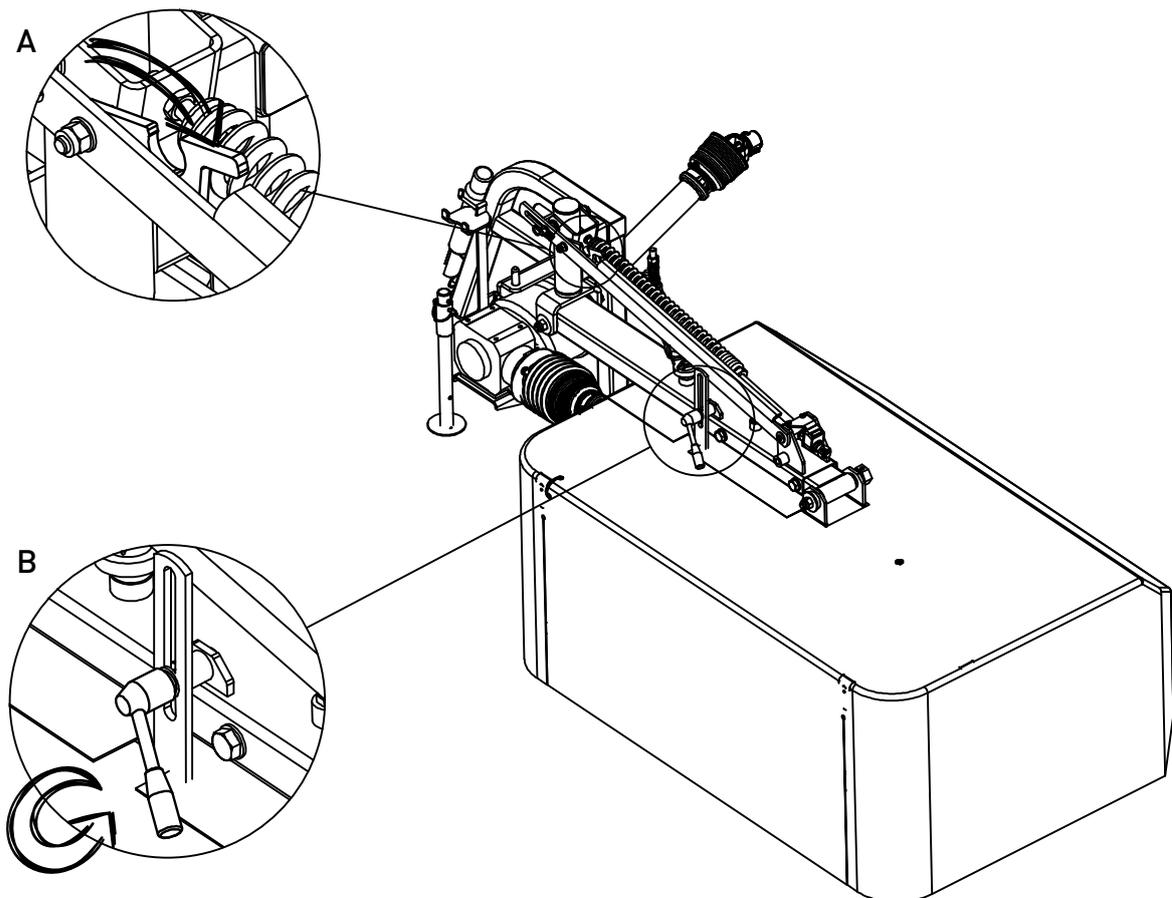

3. Remove the safety R-pins from the safety release bar.

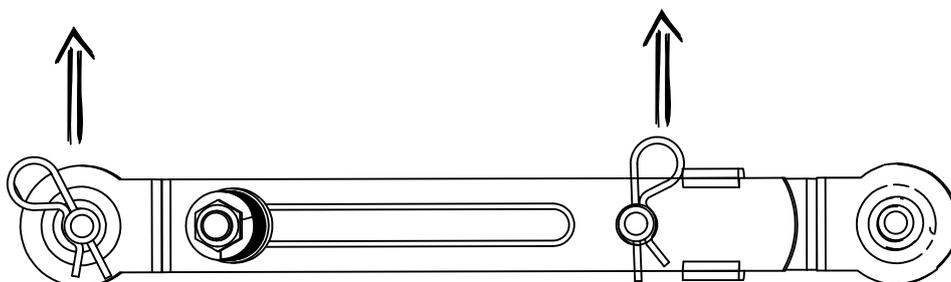

4. Remove completely the safety release bar from both the pins.

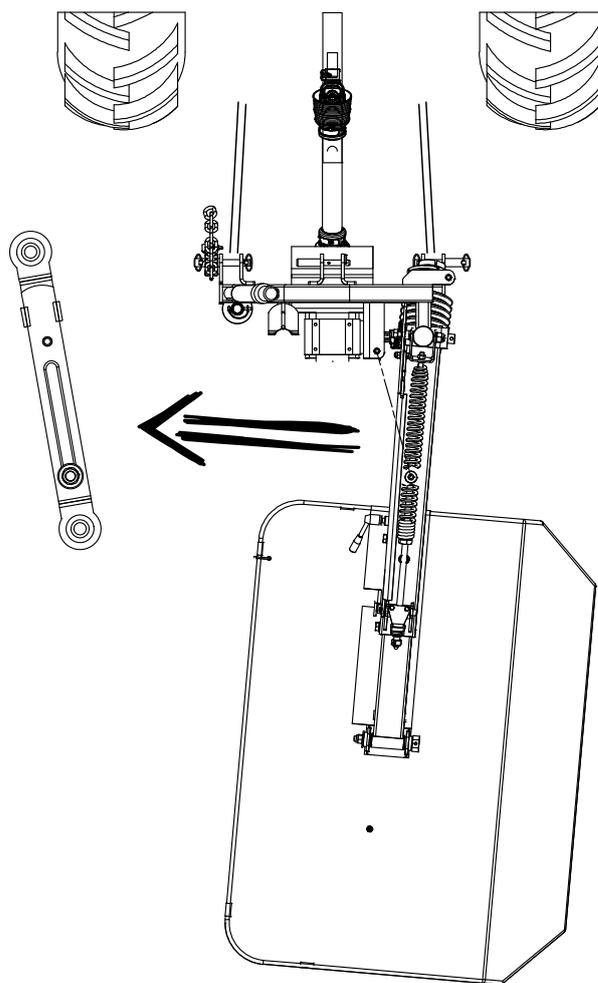

5. Rotate the mower until the locking pivots fit into the holes of the safety release bar.

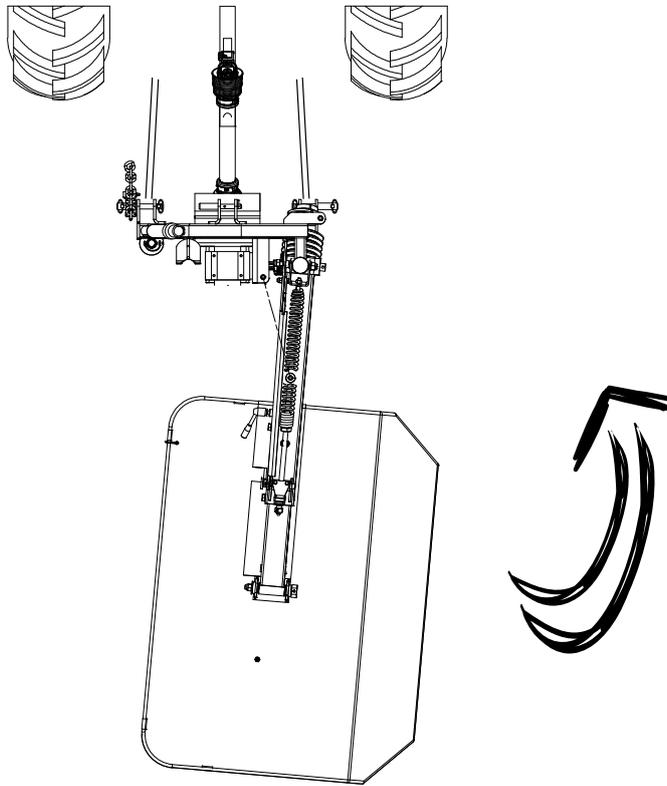

6. Position the breakaway system on the pivots on the machine's frame.

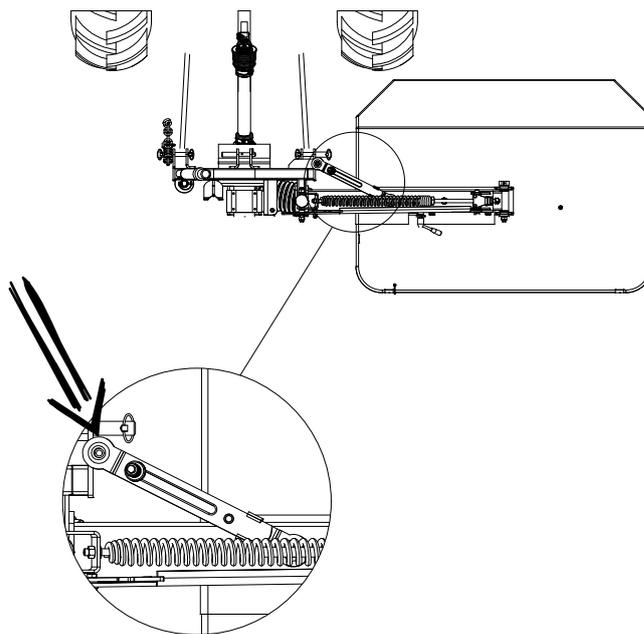

7. Insert the safety R-pins in the pins of safety release bar.

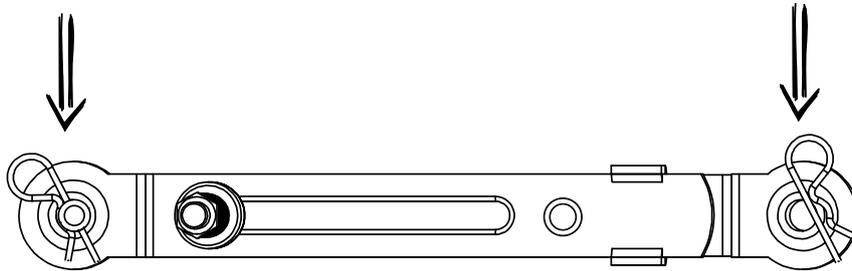

**Always switch off the tractor engine before you leave the tractor cab.**

It is recommended to work at a speed between 8 and 12 km/h. Anyway speed shall depend upon the kind of terrain.

During working avoid turns with the machine lowered to the ground and do not drive the tractor in the reverse motion.

**Before changing direction and turning raise the mower and disengage power takeoff.**

Hard working conditions, for instance rough terrain, require a lower speed.



**Use tractor with cabin and to mount a protective grid behind the driver's seat to protect operator against thrown objects.**

**Start off driving** at a slow speed and gradually increase your speed while maintaining complete control of the tractor and mower.

Moving slowly at first will also prevent the tractor from rearing up and loss of steering control. The tractor should never be operated at speeds that cannot be safely handled or which will prevent the operator from stopping quickly during an emergency.

If the power steering or engine ceases operating, stop the tractor immediately as the tractor will be difficult to control.

To avoid overturns, drive the tractor with care and at safe speeds, especially when operating over rough ground, crossing ditches or slopes, and turning corners.

Tractor wheel tread spacing should be increased when working on inclines or rough ground to reduce the possibility of tipping.

Use extreme caution when operating on steep slopes. Keep the tractor in a low gear when going downhill.

#### 4f. Stop the Tractor



Always switch off the tractor engine before you leave the tractor cab.

#### Procedure:

1. Stop the tractor.
2. Moves the Mower to the transport position.
3. Switch off the tractor engine.
4. Disengage the PTO shaft.



Wait for all moving parts of the Mower to stop.

## 4g. Disconnect the Mower to the tractor



Always position the tractor on solid ground before you disconnected the mower from the tractor.



Make sure there are no persons near the mower when you disconnected it from the tractor.

### Procedure:

1. Switch off the tractor engine.
2. Disconnect the chain and the PTO to the tractor.

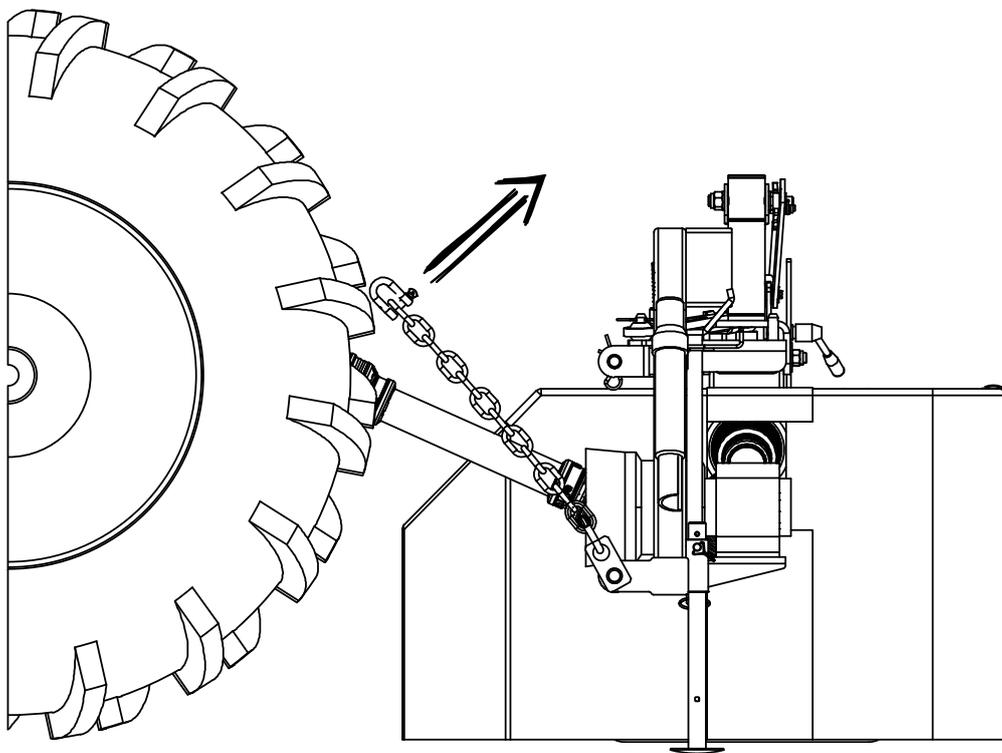

3. Disconnect the three point to the upper hitch link.

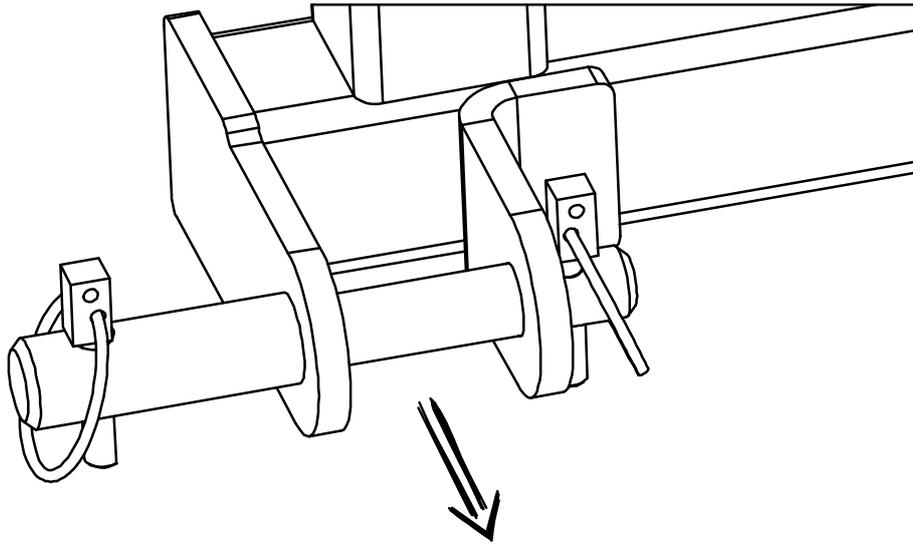

4. Position the parking jack to the lowest position. **(Point B Figure 1)**

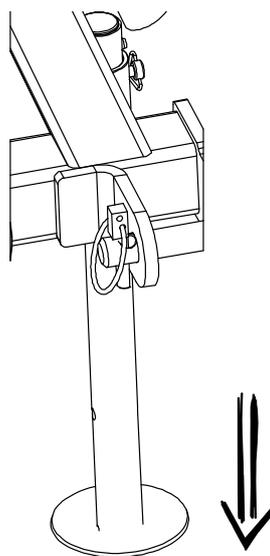

## 4 h . Breakaway reset



To reset the breakaway system after an impact proceed as shown below:

1. Get off the tractor and check the status of the machine, make sure that there aren't any damages.
2. Reset the breakaway pushing manually the bar (like shown in the image below.)

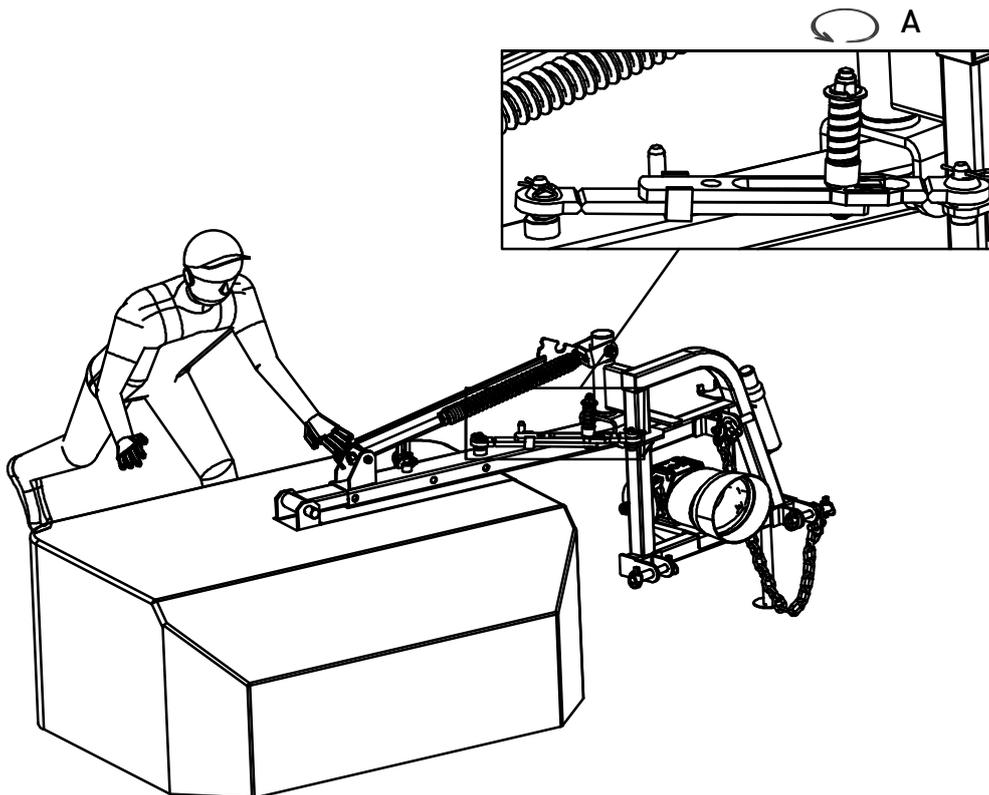

3. If the reset is difficult, unscrew the upper nut on the spring.  
(See point A.)

#### 4 i. Breakaway adjustment

- In case of an impact, if you want that the breakaway system open/separate more easily, unscrew the upper nut on the spring (see image below) to reach the wanted tightening.

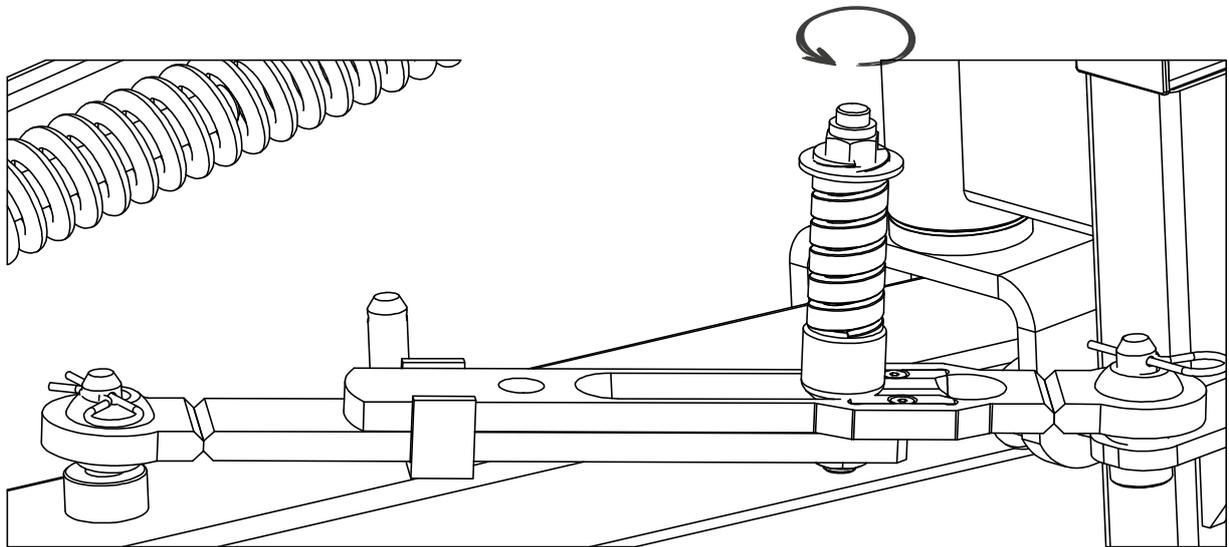

## 5. MAINTENANCE

### 5a. General maintenance

This sections contains recommendations for regular maintenance of the machine, basing on company experience as well as suggestions by our customers.

These recommendations can be furtherer integrated by contributions from our customers, for which we thank you very much in advance.

Careful and systematic servicing helps reduce maintenance costs and ensure efficient operation.



**Before maintenance, adjustment and cleaning lower the machine to the ground, turn off the engine of the tractor, disengage power takeoff, set hand brake, remove the ignition key.**

If there is any trouble the operator shall stop the machine, identify the trouble and make repairs if necessary.

If you use compressed air or water for cleaning the machine, wear suitable safety glasses or masks and keep people and animals away. Do not use any inflammable fluids.

During maintenance wear the suitable Protective Devices (safety shoes and gloves) and follow all relevant safety precautions.

It is recommended to check tightness of all nuts and bolts, including those of knives, **every 8 hours of work**.

### 5b.Storage

If the machine is not used for a long period it is necessary to store it inside to avoid exposure to weather and dust. Before operating it again, it is good practice to clean the machine and lubricate all mechanical components to prevent dust.

- Clean the machine thoroughly.
- Inspect the machine for damaged parts and scratched paint.
- Make sure that safety signs are legible and located properly on the machine. Replace damaged safety labels.
- Replace damaged or worn curtain **(See par. 5e)**.
- Lubricate all mechanical components, locking pins, the coupling head to the cardan joint **(See par. 5c)**.
- Replace oil in the gearbox and in the cutter bar following the instructions.
- If possible, store the machine in an enclosed place.

### 5c. Lubrication



Before performing an inspection, stop the engine of the tractor, remove the ignition key and disengage cardan-shaft transmission.

Collect used oil and bring it to the Oil Collection Centre. Do not pollute the environment.

#### c1. Lubrication of mechanical components

Each day after working with the mower, clean it and check its technical condition.

- When the mower is not used for a longer period, clean and grease the drive shaft.
- In winter and when the temperature is very low protect grease pipes with plastics.
- Clean debris from the lubricators heads before injecting lubricating grease.
- Clean following points with lithium grease.
- Greasing lower discs bearings: you can access into the lubricant placed on the shaft of the drum, removing the lower disc cover. Use grease NLGI=2. **(Point A Figure 3)**

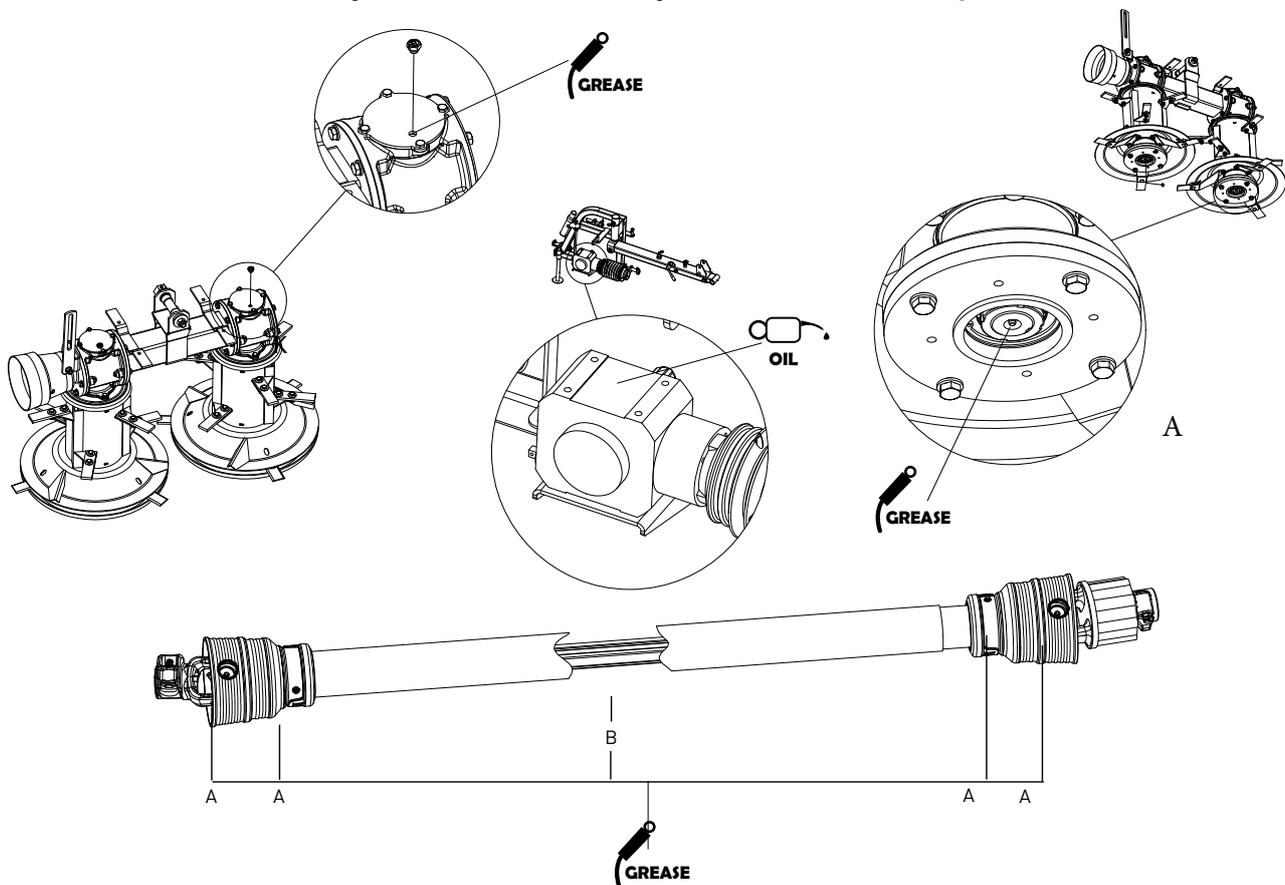

Figure 3 Lubrication of mechanical components.

## c2. Lubrication of the centre gearbox

- In order to check oil level, stop the machine and make sure it is set in horizontal position. Use SAE 90EP oil (synthetic oil in case of external high temperature).
- Change oil in the unit after the first 10/15 hours of work.
- Replace oil every 500 hours of work and at least once a year. (Oil quantity 0,7 Lt)  
When the mower is used for a long period, check oil level on a daily basis and add oil if necessary.
- Use a dipstick to check oil level.

## c3. Lubrication of overgear unit

- Use grease GULF CROWN EP 00 or SHELL GADUS S2 V220 00. (See table below)
- Check that there is always grease in the gears and add grease if necessary.

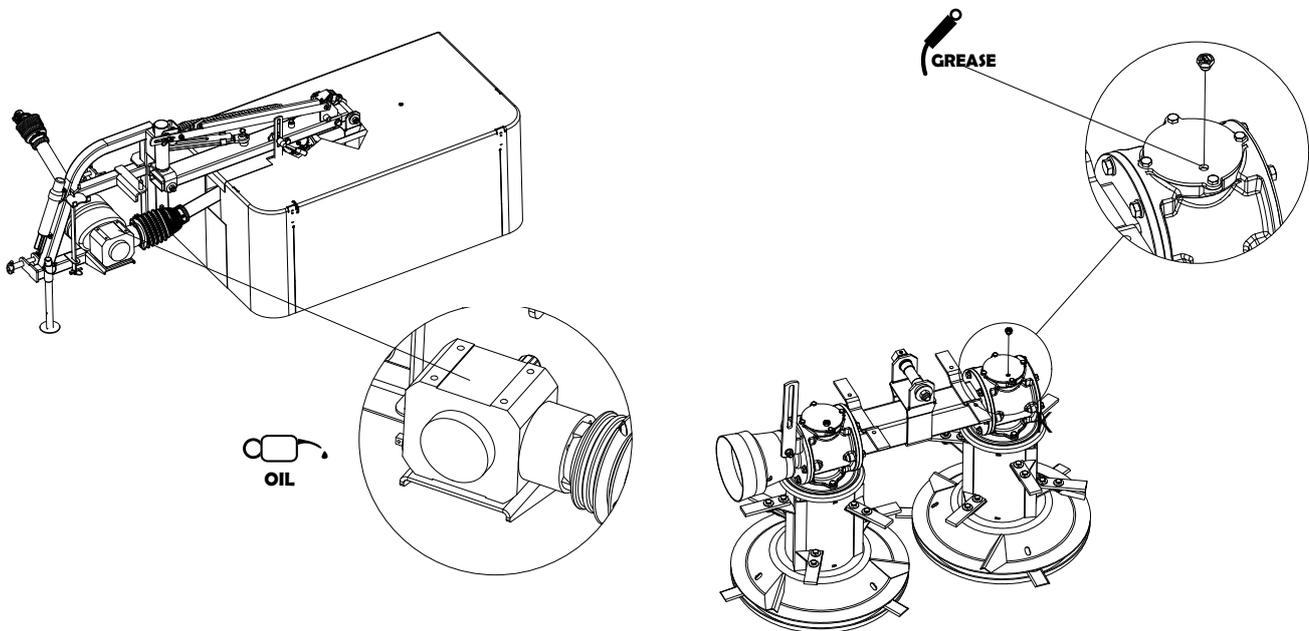

Properties			Method	SHELL GADUS S2 V220 00	GULF CROWN EP 00
Consistency NLGI				00	00
Kind of soap				Lithium	Lithium
Type of lubricant				Mineral	Mineral
Viscosity	a 40 °C	Cst	IP 71/ ASTM D445	220	300
Viscosity	a 100 °C	Cst	IP 71/ ASTM D445	19	-
Processed penetration	a 25 °C	0.1mm	IP 50/ ASTM D217/ ISO 2137	400-430	-
	60 stroke			-	400-430
drop point		°C	IP 396	-	>160
4-ball-welding test		Kg minimum	ASTM D2596	250	
		N	DIN 51350-4		2600
Temperature range		°C		-20 °C to +100 °C Maximum +120 °C	-30 °C to +100 °C Maximum +120 °C

Figure 4 Lubrication points.

### 5d. Knives

Working on rough terrain may cause damages to knives (deformation and scratches) and therefore lower cutting quality while increasing the risk of accidents and wear.

Damaged knives can more easily be thrown away from the machine and cause serious injury to the operator and other people even at a relevant distance.

Fasteners of knives shall be checked regularly.



The replacement of knives is an operation really dangerous therefore it is necessary that it must be done from specialized person.

Make a careful inspection after an obstacle is hit, or knives have been replaced and at the beginning and at the end of the season.

Drums have been previously equilibrated electronically: it is recommended to replace all tools at once.

**Replace worn or deformed discs. Never replace one knife only. When one knife is worn, replace all of them.**

Knives provided with conditioner-equipped machines bear an arrow to indicate knife rotation direction.

**Use exclusively original Terra Implements knives.**

Knives replacement is quick and easy. Lift the machine (10 cm to the ground) and use the special included tool to open the knife is properly seated on the spindle.

Never replace one knife only. When one knife is worn, replace all of them.

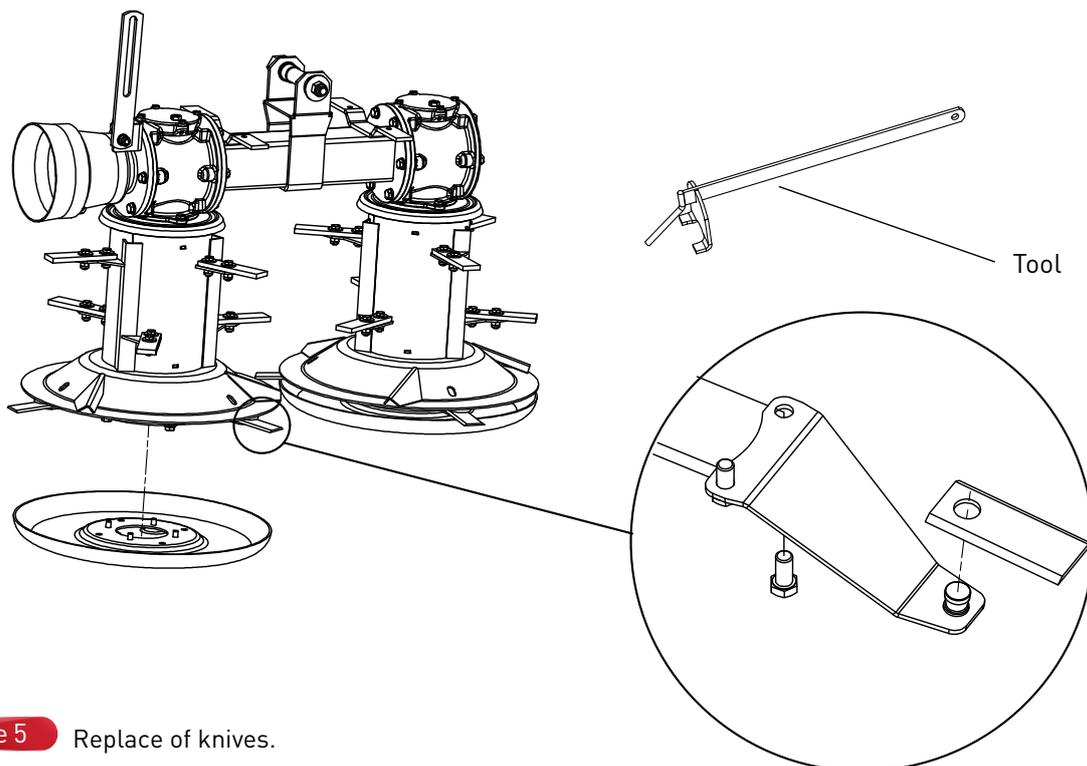

Figure 5 Replace of knives.

## 5e. Curtain replacement

Before any operation check wear on the curtain and on the attaching devices. Replace worn curtain.

Use exclusively curtains supplied by Terra Implements.

In order to remove the damaged curtain, remove the zip-ties, replace the new curtain on the protection frame and tie the zip-tie.



**NEVER** remove the curtain while operating the mower.

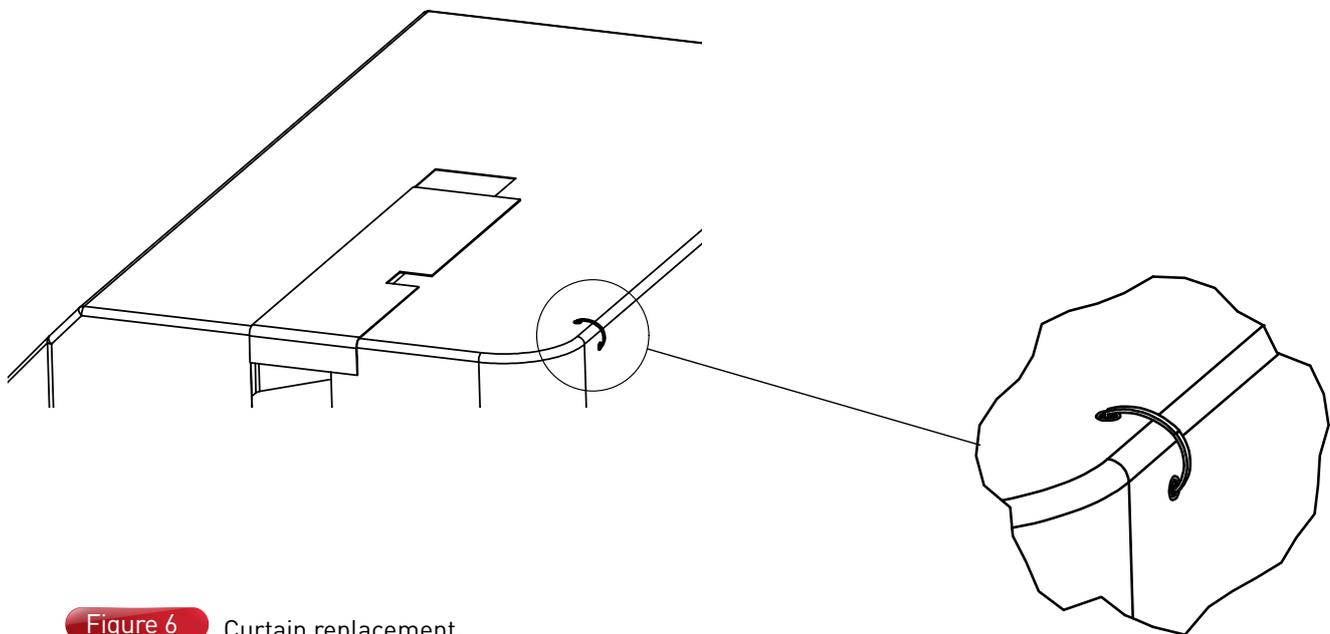

Figure 6 Curtain replacement.

## 5f. Disposal and scrapping

The machine shall be scrapped in suitable dumps in compliance with the existing law.

Collect used oil and dispose it according state and local regulations.

Used oil is harmful according to the existing law, therefore it shall be properly collected. Collect properly plastics, aluminium and steel components for them to be recycled.

## 6. WARRANTY

The Manufacturer warrants its brand-new products for a period of 12 (twelve) months from the date of purchase \*. On receiving the machine, check to make sure it is intact and all parts accounted for.

Any complaints must be made in writing within 8 (eight) days of receipt of the machine.

The user's sole remedy under warranty shall consist in the repair or replacement free of charge of any parts proving to be defective subsequent to a thorough examination by the Manufacturer's engineering department (and does not include electrical parts or any implements).

Under no circumstances shall the repair or replacement of parts covered by the warranty extend the warranty period.

The purchaser may only enforce the warranty if the conditions concerning the warranty service, also featured in the supply contract, have been met.

### 6a. Exclusion from warranty

The warranty becomes void (in addition to those situations featured in the supply contract):

In the event of an incorrect manoeuvre attributable to the operator.

In the event the damage can be attributable to poor maintenance.

In the event the machine is altered, following repairs carried out by the user without the Manufacturer's permission or subsequent to the fitting of non-original spare parts, and the damage is the result of said alterations.

In the event the instructions featured in this manual have not been followed. Neither shall the warranty cover any damage resulting from negligence, carelessness, bad operation or improper use of the machine.

Neither shall the warranty cover any damage resulting from negligence, carelessness, bad operation or improper use of the machine.



The removal of the safety devices supplied with the machine shall automatically cause the warranty to become void and relieve the Manufacturer of any liability. In addition, the warranty shall become void in the event non-original spare parts are used. The machine, or parts of it, must be returned carriage free, even when under warranty.

The warranty have to be required only from the dealership. No warranties will be accepted if sent directly from the farmer.

**\* THE WARRANTY STARTS** when the machine is registered to the website following the instructions you'll find in the next pages. **PLEASE RECORD YOUR MACHINE** immediately (if you don't have internet connection ask help to your dealer), take note that the only document accepted to register your machine is the dealer invoice or receipt of payment **WITH DATE OF PURCHASE**.

## 6b. Instructions

1. Connect to the site: [www.terra-implements.it](http://www.terra-implements.it)
2. Select the section "Customer warranty"  
([www.terra-implements.it/customer-warranty/](http://www.terra-implements.it/customer-warranty/)) (Figure 7)
3. Fill the form with all the required fields. (Figure 8)
4. Push "SEND". (Figure 9)

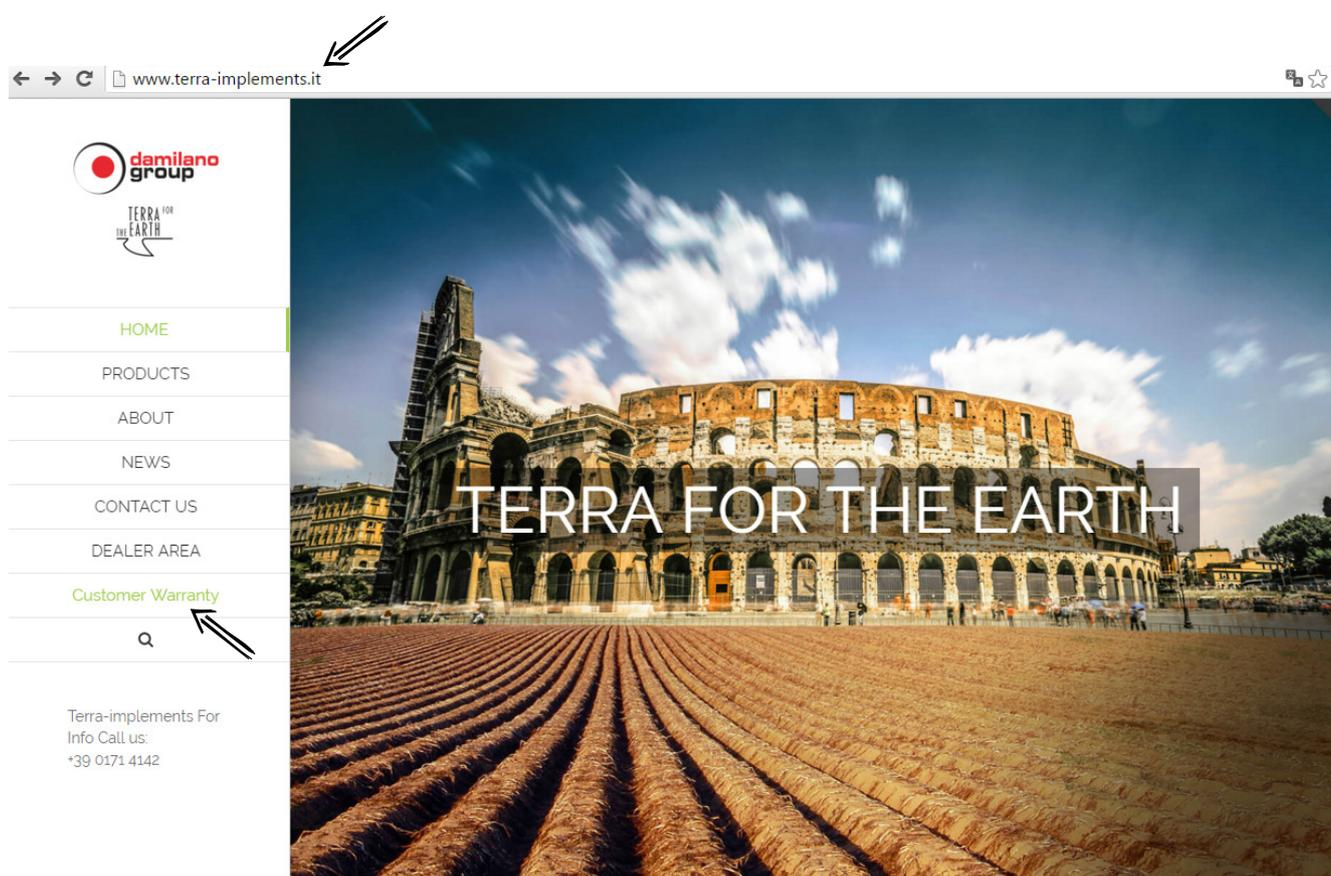
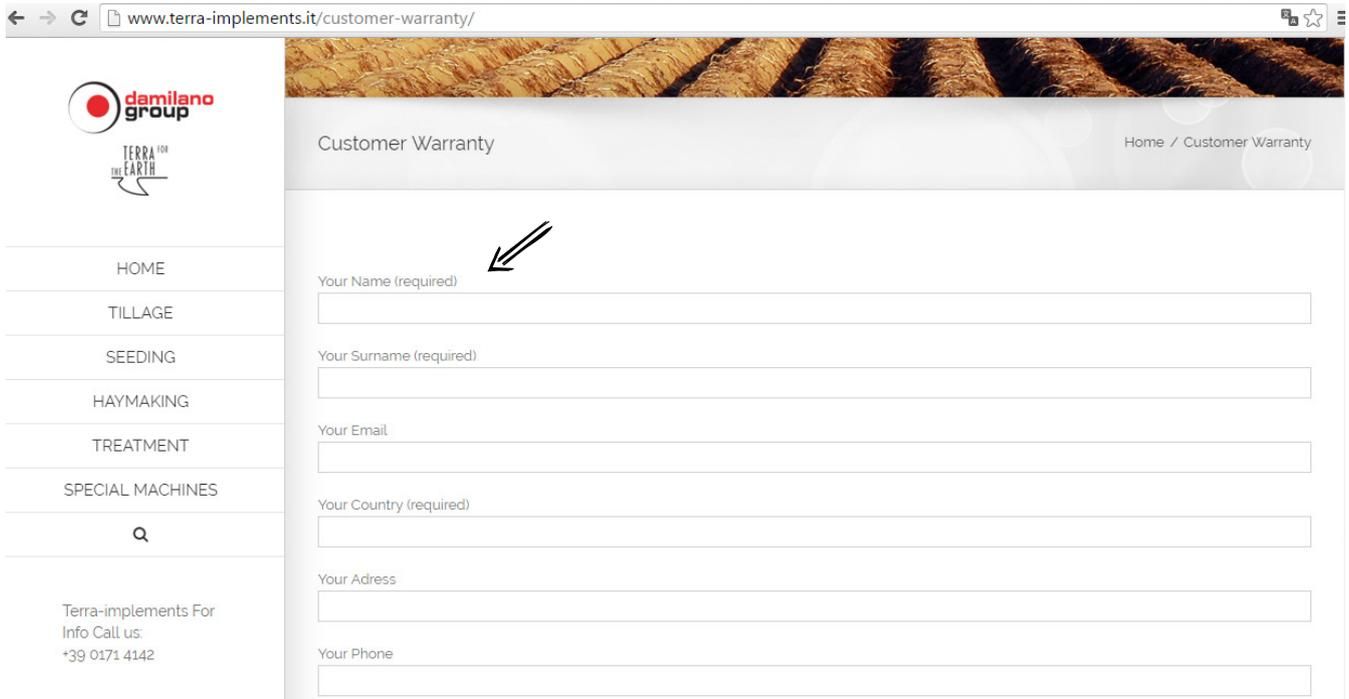

Figure 7



www.terra-implements.it/customer-warranty/

Customer Warranty Home / Customer Warranty

Your Name (required) 

Your Surname (required)

Your Email

Your Country (required)

Your Address

Your Phone

Figure 8

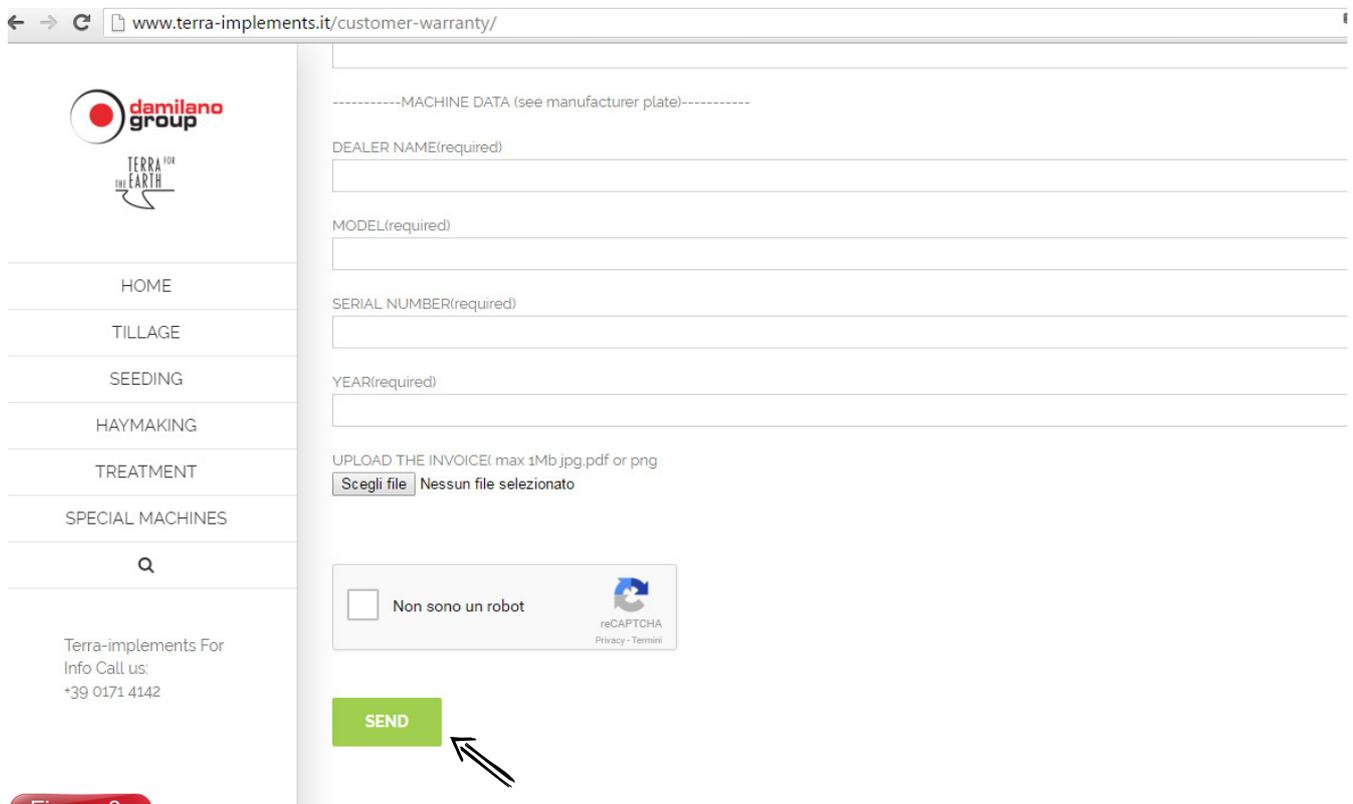

www.terra-implements.it/customer-warranty/

-----MACHINE DATA (see manufacturer plate)-----

DEALER NAME(required)

MODEL(required)

SERIAL NUMBER(required)

YEAR(required)

UPLOAD THE INVOICE(max 1Mb .jpg .pdf or .png)  
Scegli file | Nessun file selezionato

Non sono un robot 

SEND 

Figure 9

## 7. PART LIST

**All the components of the mower can be requested to the Manufacturer specifying:**

- Machine model.
- Serial number of the machine.
- Production year. Code of the part you need (you will find it in the spare parts book), description and quantity.
- Transport device. In case that this voice isn't mentioned, the Manufacturer doesn't reply in case of delay in the delivery. Freight costs are always at charges forward.

**All the spare parts have to be ordered through the website by the dealership in the "dealer area" after login in.**

**The Manufacturer is always available for every kind of commercial and technical request you may have.**



**MAINTENANCE-REPAIR AND OPERATING HAND BOOK**  
OPERATING MANUAL SPARE PARTS CATALOGUE



**CONTACT**

[service@terra-implements.it](mailto:service@terra-implements.it)  
tel. +39 0171 4142  
[www.terra-implements.it](http://www.terra-implements.it)  
ITALY