

**SARRACENIA 180**

Manual version

PART LIST







**MAINTENANCE-REPAIR AND OPERATING HAND BOOK**  
OPERATING MANUAL SPARE PARTS CATALOGUE



## SPARE PARTS

When ordering spare parts, it is important that you indicate the type and serial number of your machine.  
Use only genuine Terra Implements parts.  
Complete the type and serial number.  
This is an easy reference with a view to future spare parts ordering.

## PIECES DE RECHANGE

En commandant des pièces de rechange il importe que vous indiquiez les numéros de type et de série de votre machine. N'utiliser que des pièces d'origines Terra Implements.  
Veuillez noter, ci-dessous, les numéros de type et de serie.  
Ceci est important pour toutes commandes de pièces de refiechange.

## PIEZAS DE REPUESTO

Cuando ordene piezas de repuesto, es importante que indiqués el tipo y número de serie de su máquina.  
Utilice sólo piezas de Terra Implements.  
Completar el tipo y número de serie.  
Esto es una referencia fácil para futuros recambios pedidos.



 by DAMILANO GROUP srl  
Via Fratelli Ceirano, 19/21  
Cuneo - 12100 - (CN)  
Italy  
Tel.: +39 0171 414219  
Fax.: +39 0171 414219

Modello:

N°:

Massa:



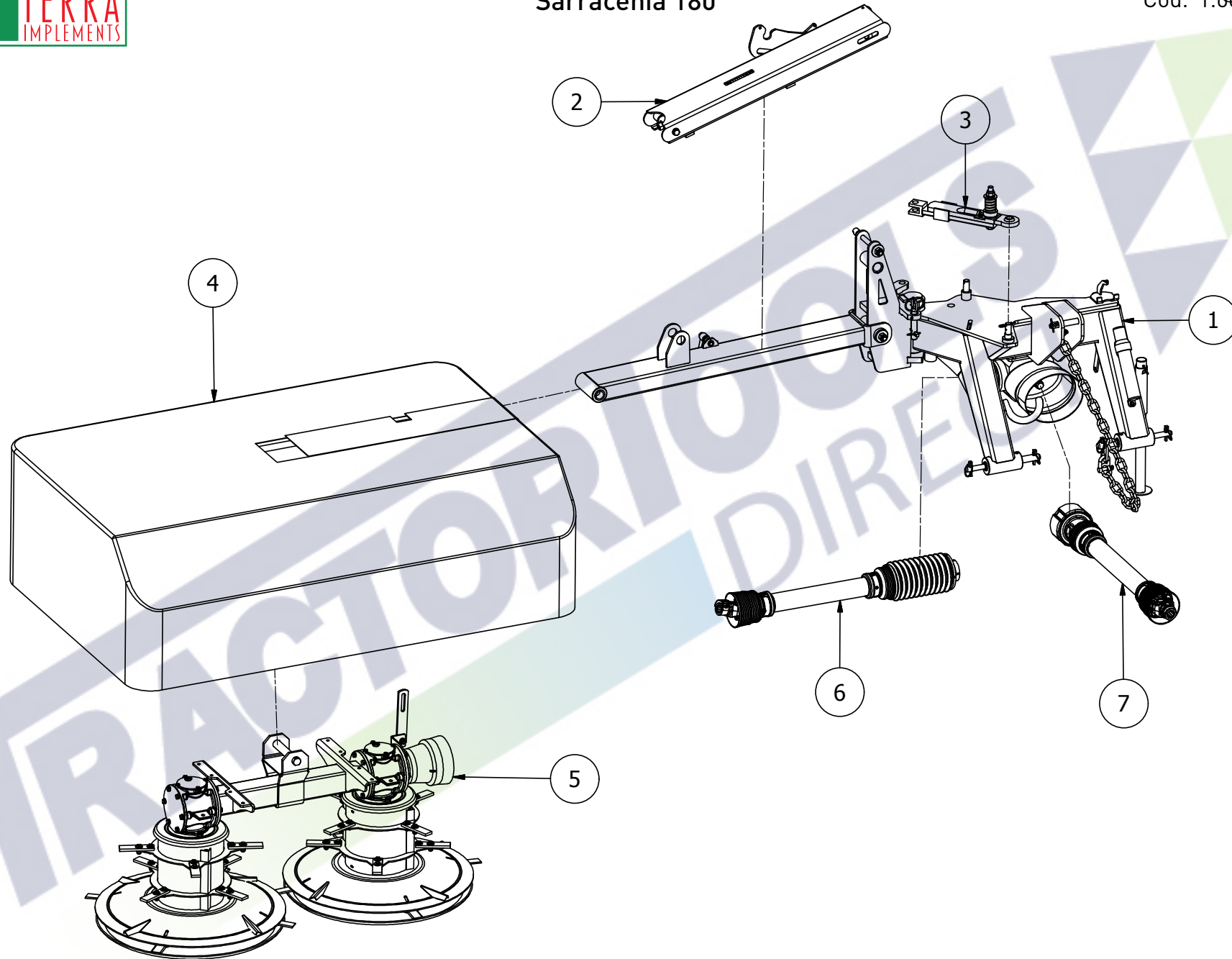

Pos.	Code	Description	Quantity
1	5.013.0003	Connecting frame	1
2	5.015.0002	Suspension group	1
3	5.014.0002	Breakaway	1
4	5.007.0007	Guards assembly	1
5	5.012.0002	Cutter bar group	1
6	5.016.0013	Intermediate PTO shaft	1
7	5.016.0015	PTO shaft	1

TRACTORTOOLS  
DIRECT

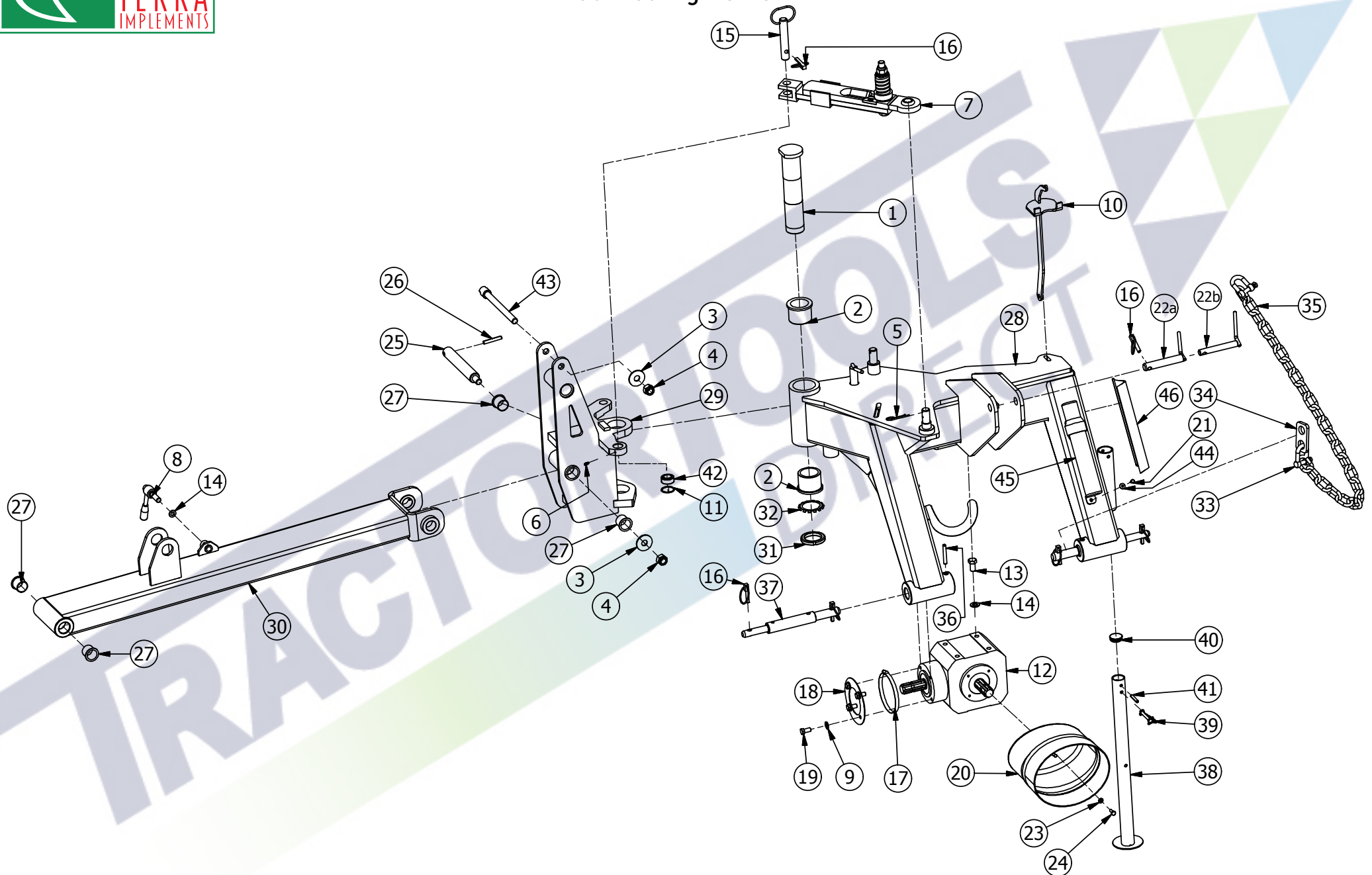

## Connecting frame

Cod. 5.013.0003

Pos.	Code	Description	Quantity	Net Price \$
1	4.003.0008	Fixing pin	1	33,00
2	2.012.0012	Bushing	2	2,20
3	2.003.0038	Wide Flat Washer ISO 7093/2 D20	2	1,10
4	2.002.0055	Self locking Nut ISO 7040 UNI 7473 M20	2	1,10
5	2.009.0206	Cotter pin D=3.5 L=80	1	1,10
6	2.013.0004	Greaser DIN 71412 -A M6	1	1,65
7	5.014.0002	Breakaway	1	146,85
8	2.016.0002	Adjustable handles with threaded stud	1	1,10
9	2.003.0006	Flat Washer ISO 7089 D12	4	1,10
10	4.007.0002	Tool release blades	1	33,00
11	2.021.0010	Seeger ring for holes SB42x1,75	1	6,60
12	5.009.0003	Gearbox	1	462,00
13	2.001.0127	Hex. Screw ISO 4017 M16x30	4	1,10
14	2.003.0008	Flat Washer ISO 7089 D16	4	1,10
15	4.003.0022	Pin	1	2,20
16	2.009.0208	Locking pin D11	5	1,10
17	2.010.0010	Zip tie	1	5,50
18	3.012.0142	Plate	1	5,50
19	2.001.0083	Hex. Screw ISO 4017 M12x20	4	1,10
20	2.010.0007	PTO guard	1	35,20
21	2.001.0019	Hex. Screw ISO 4017 M6x16	2	1,10
22a	4.003.0033	Connecting pin Cat. II	1	7,70
22b	4.003.0040	Connecting pin Cat. I	1	5,50
23	2.003.0004	Flat Washer ISO 7089 D8	4	1,10
24	2.001.0040	Hex. Screw ISO 4017 M8x20	4	1,10
25	4.003.0023	Pin	1	5,50
26	2.009.0133	Slotted spring pin ISO 8752 D10x65	1	1,10
27	2.012.0013	Bushing 3539-36	4	2,42
28	4.001.0005	3 point hitch for drums mower 180	1	605,00
29	3.009.0015	Pivoting assembly	1	165,00
30	4.002.0004	Support beam	1	198,00
31	2.023.0003	Ring nut M60x2	1	6,60



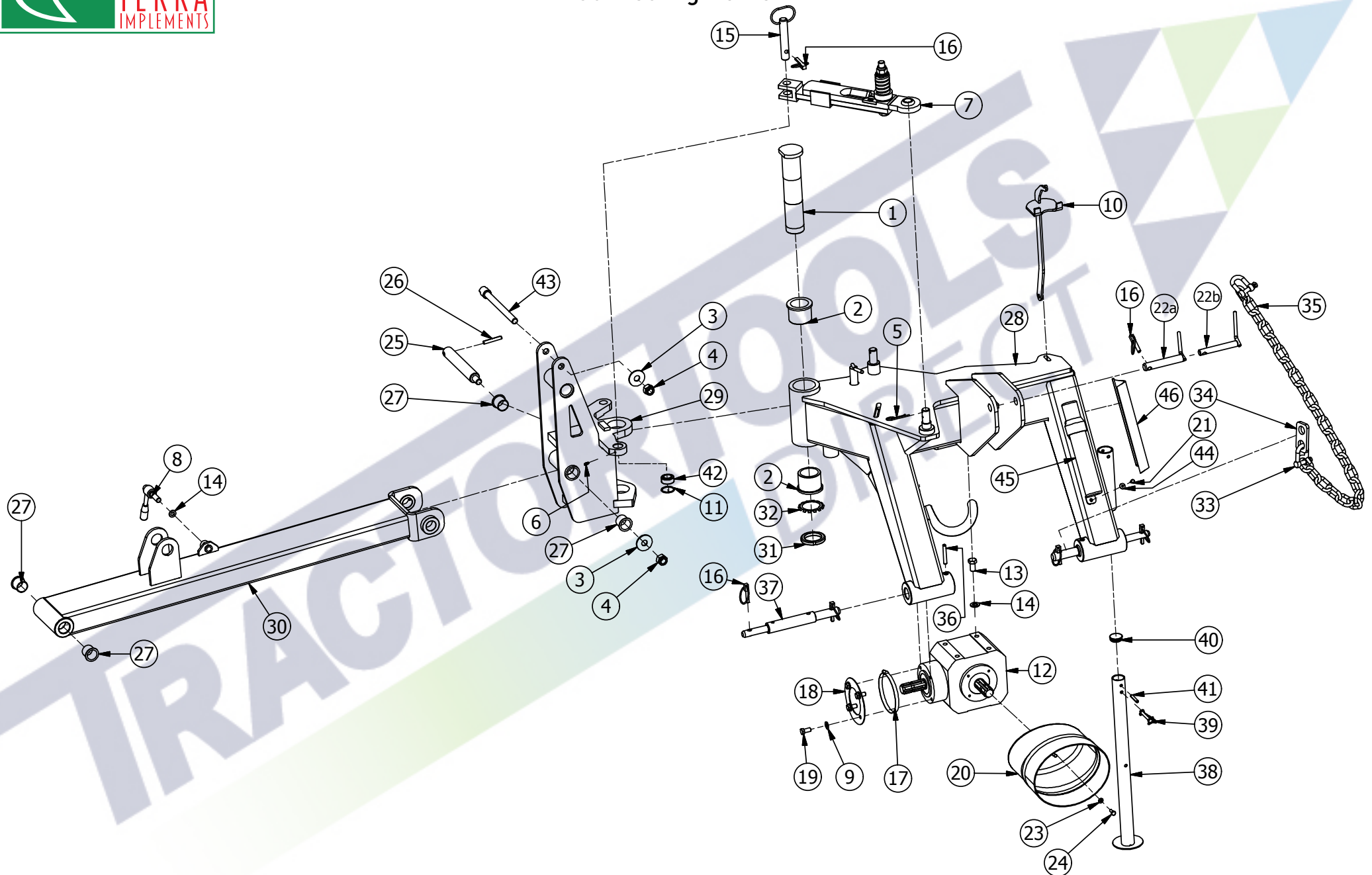



## Connecting frame

Cod. 5.013.0003

Pos.	Code	Description	Quantity	Net Price \$
32	2.024.0002	Safety washer	1	4,95
33	2.031.0003	"D" shackles	2	4,40
34	3.012.0159	Plate	1	5,50
35	2.031.0004	Chain	1	4,40
36	2.009.0134	Slotted spring pin ISO 8752 D10x70	2	1,10
37	4.003.0038	Lower Pin Cat I and II	2	38,50
38	4.008.0003	Support foot	1	38,50
39	2.009.0205	Spring pin D=8 L=80	1	1,65
40	2.015.0016	Plastic cap	1	1,10
41	2.009.0104	Slotted spring pin ISO 8752 D8x50	1	1,10
42	2.011.0007	Ball junction	1	7,70
43	4.003.0026	Fixing pin	1	19,80
44	2.003.0031	Wide Flat Washer ISO 7093/2 D6	2	1,10
45	2.010.0002	Canister D=56 L=320	1	17,60
46	7.003.0051	Manual Sarracenia 180	1	4,40

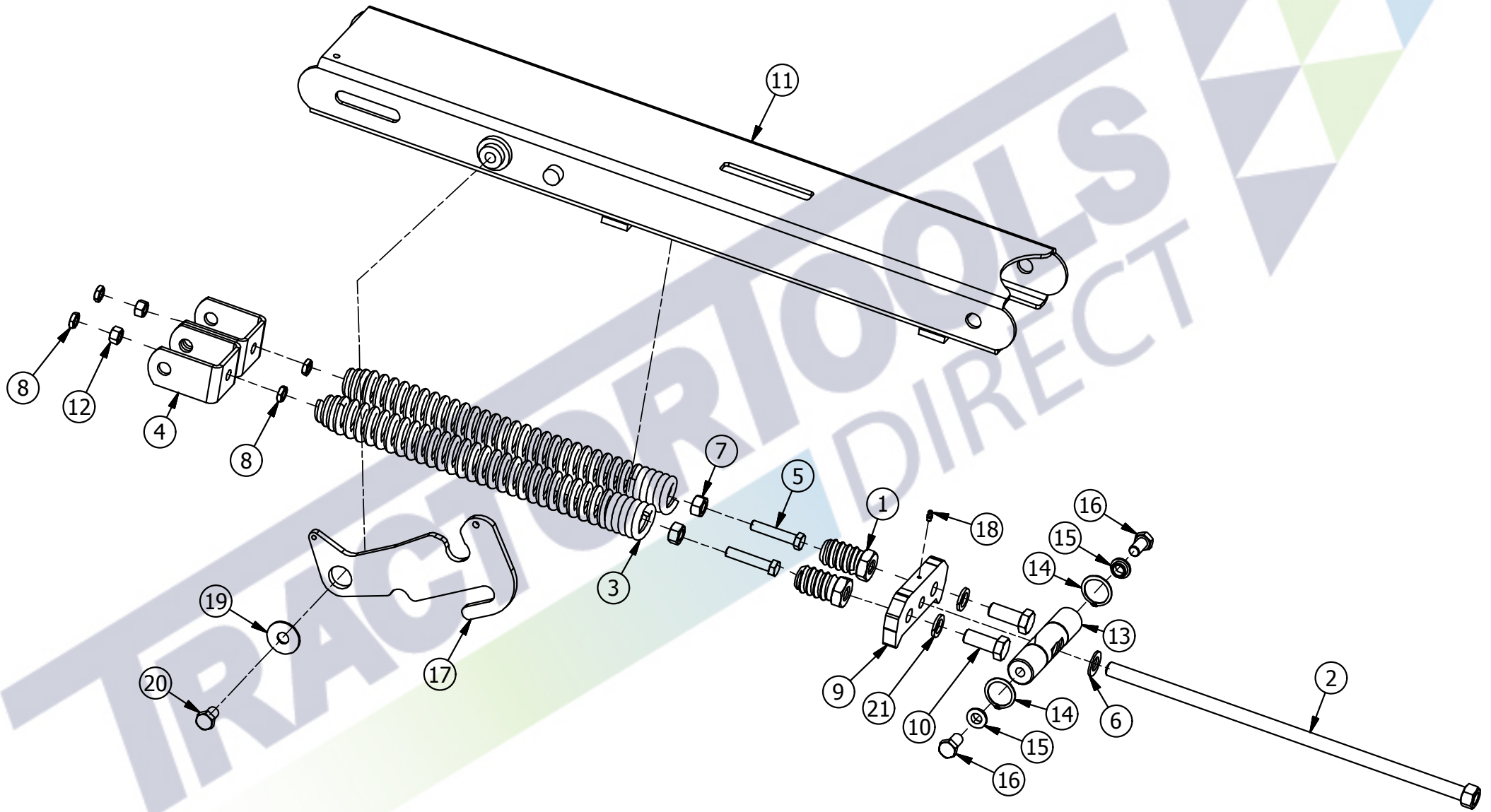

## Suspension group

Cod. 5.015.0002

Pos.	Code	Description	Quantity	Net Price \$
1	3.010.0003	Fixing spring hexagon	2	19,80
2	4.012.0031	Threaded bar M20 with welded nut	1	52,80
3	3.018.0001	Spring	2	39,60
4	3.012.0007	"C" support for spring	2	24,20
5	2.001.0116	Hex. Screw ISO 4017 M14x70	2	1,10
6	2.003.0068	Brass Flat Washer ISO 7089 D20	1	1,65
7	2.002.0009	Hex. Nut ISO 4032 M18	2	1,10
8	2.002.0031	Thin Nut ISO 4035 M14	4	1,10
9	3.012.0166	plate	1	7,70
10	2.001.0171	Hex. Screw ISO 4017 M20x50	2	1,10
11	4.012.0003	Upper "C" plate spring locker	1	60,50
12	2.002.0007	Hex. Nut ISO 4032 M14	2	1,10
13	3.008.0052	Pin	1	16,50
14	2.021.0008	Seeger ring for shaft DIN 471- 40x1,75	2	6,60
15	3.007.0129	Spacer washer	2	2,20
16	2.001.0127	Hex. Screw ISO 4017 M16x30	2	1,10
17	3.012.0347	Locking hook spring	1	22,00
18	2.013.0004	Greaser DIN 71412 -A M6	1	1,65
19	2.003.0036	Wide Flat Washer ISO 7093/2 D16	1	1,10
20	2.001.0126	Hex. Screw ISO 4017 M16x25	1	1,10
21	2.003.0060	Split Washer DIN 127B UNI 1751 D20	2	1,10



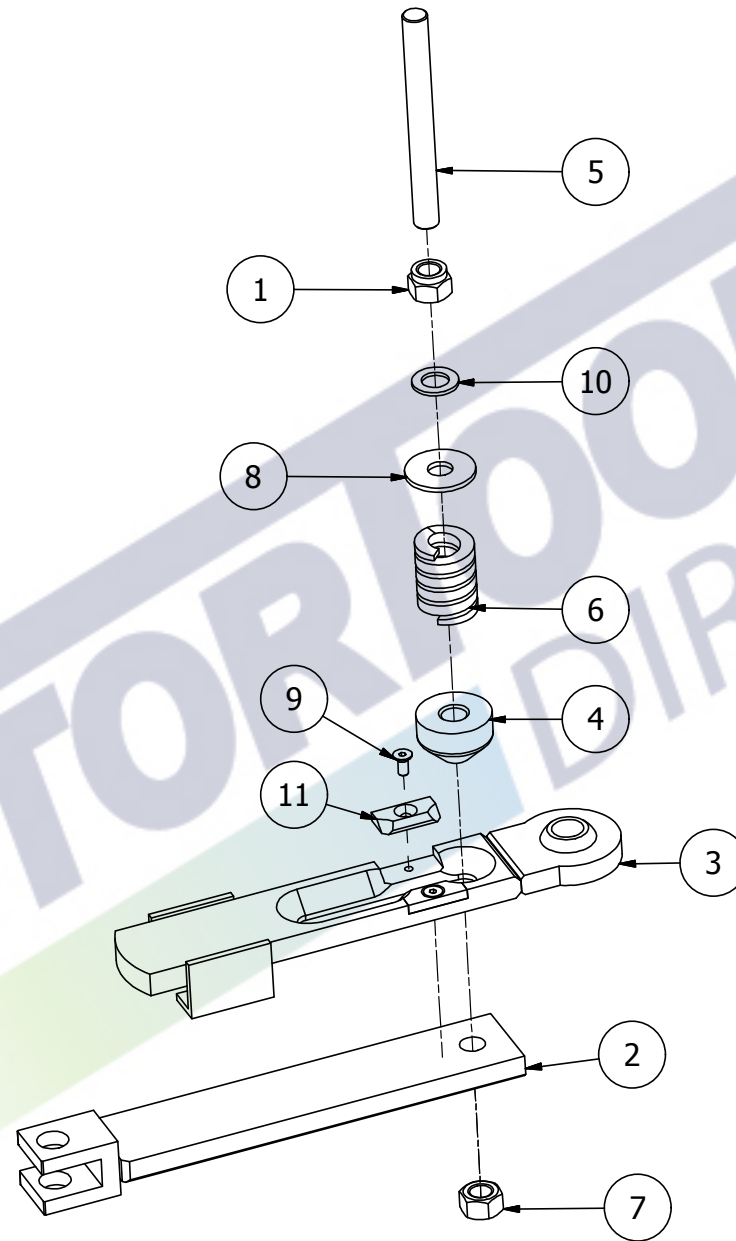

## Security disengage

Cod. 5.014.0002

Pos.	Code	Description	Quantity	Net Price \$
1	2.002.0055	Self locking nut ISO 7040 UNI 7473 M20	1	1,10
2	4.011.0004	Hole plate	1	44,00
3	4.011.0003	Eyelet plate	1	77,00
4	4.003.0029	Adjustable pin	1	13,20
5	3.015.0006	Threaded bar M20	1	16,50
6	3.018.0009	Compression spring	1	23,10
7	2.002.0010	Hex. nut ISO 4032 M20	1	1,10
8	2.003.0038	Wide Flat Washer ISO 7093/2 D20	1	1,10
9	2.001.0616	Socket cap Screw ISO 10642 M8x18	2	1,10
10	2.003.0010	Flat Washer ISO 7089 D20	1	1,10
11	3.017.0004	Hardened still plate	2	16,50

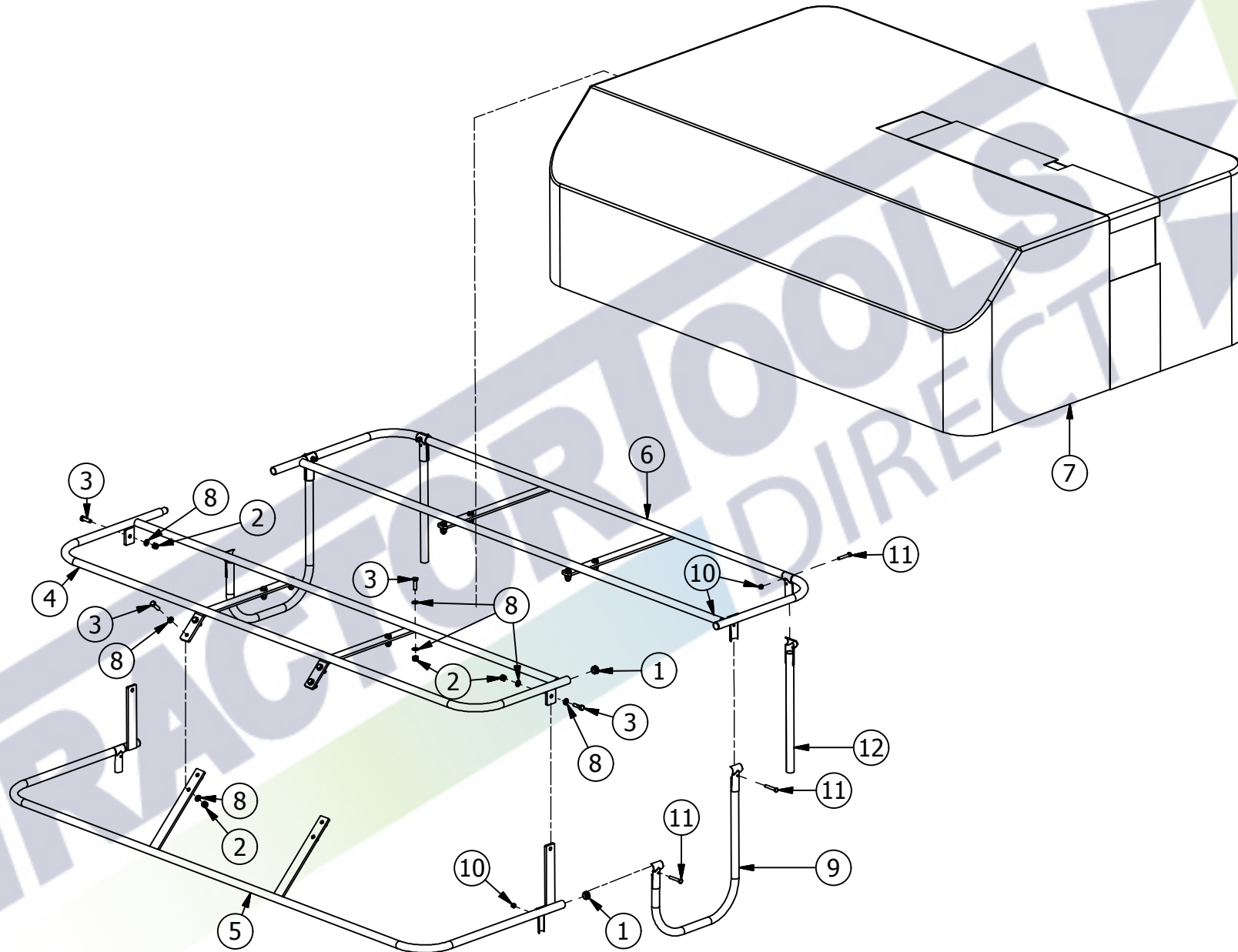



## Guards assembly drum mower 180

Cod. 5.007.0007

Pos.	Code	Description	Quantity	Net Price \$
1	2.015.0005	Plastic cap	4	1,10
2	2.002.0050	Self locking Nut ISO 7040 UNI 7473 M10	14	1,10
3	2.001.0063	Hex. Screw ISO 4017 M10x35	14	1,10
4	4.005.0005	Front frame guard for drum mower 180	1	143,00
5	4.005.0006	Extension front frame guard drum mower 180	1	110,00
6	4.005.0007	Rear frame guard for drum mower 180	1	143,00
7	3.019.0003	Plastic cover	1	275,00
8	2.003.0005	Flat Washer ISO 7089 D10	28	1,10
9	4.012.0028	Guard pipe	2	16,50
10	2.002.0049	Self locking Nut ISO 7040 UNI 7473 M8	6	1,10
11	2.001.0047	Hex. Screw ISO 4017 M8x50	6	1,10
12	4.012.0015	Guard pipe	2	7,70

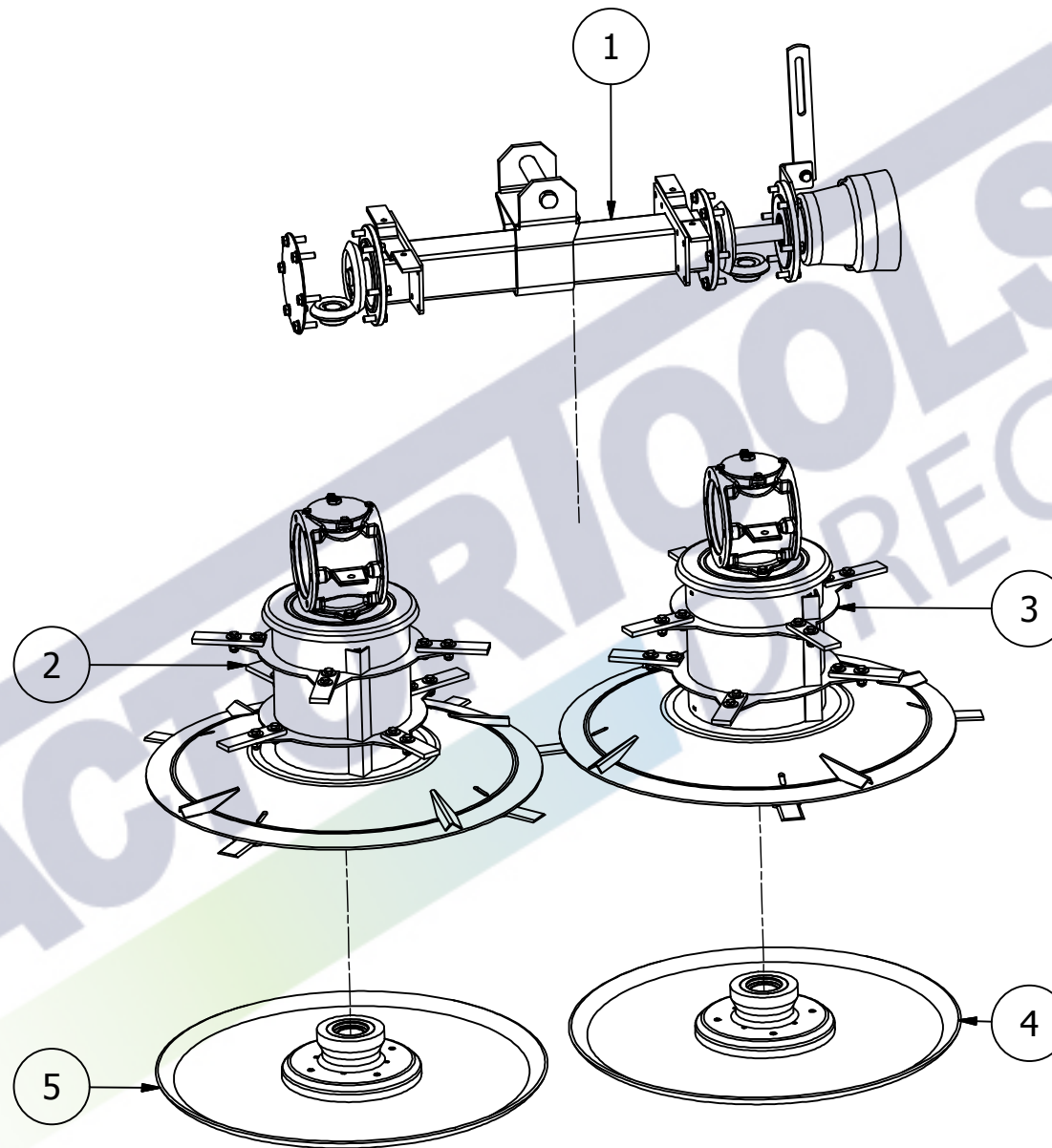

## Cutter bar group for drum mower 180

Cod. 5.012.0002

Pos.	Code	Description	Quantity
1	5.010.0011	Crossbar gearbox for drum mower 180	1
2	5.010.0009	Left drum gearbox for drum mower 180	1
3	5.010.0010	Right drum gearbox for drum mower 180	1
4	5.010.0016	Right lower disc group for drum mower 180	1
5	5.010.0021	Left lower disc group for drum mower 180	1

TRACTORTOOLS  
DIRECT



# Crossbar gearbox

Cod. 5.010.0011

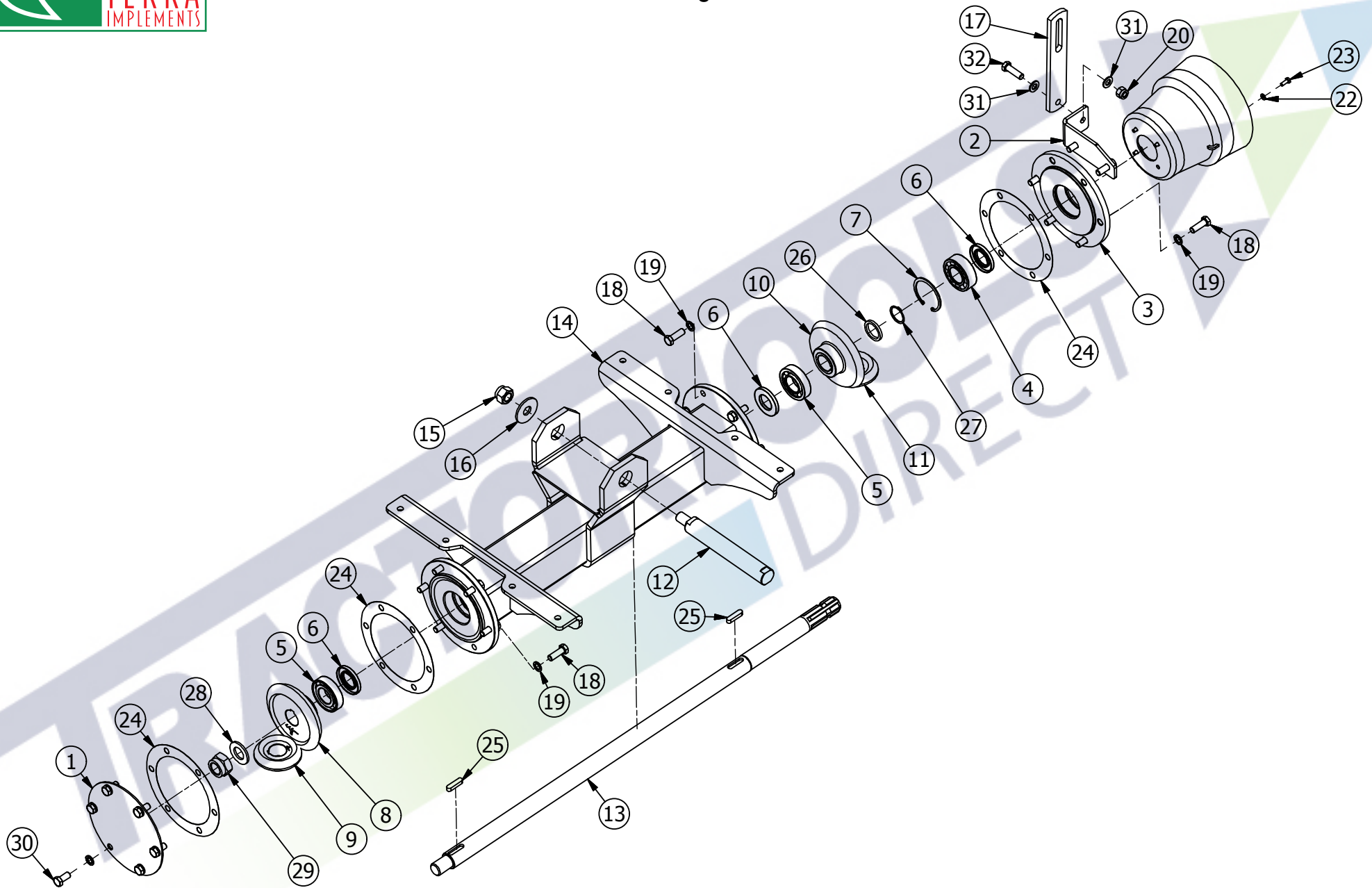

## Crossbar gearbox

Cod. 5.010.0011

Pos.	Code	Description	Quantity	Net Price \$
1	3.012.0004	Plate	1	11,00
2	3.012.0149	Support for locking tilting plate	1	9,90
3	3.008.0008	Oblique roller bushing support flange	1	61,60
4	2.004.0003	bushing 2207 TV (35-72-23)	1	35,20
5	2.004.0004	bushing 7207 BECBY (35-72-17)	2	27,50
6	2.020.0001	Sealing ring DIN 3760 - AS - 35 x 62 x 7 - NBR	3	5,50
7	2.021.0001	Seeger ring for holes DIN 472 - 72x2,5	1	6,60
8	3.004.0004	Right Conical gear Z=37	1	143,00
9	3.004.0005	Left Conical gear Z=23	1	99,00
10	3.004.0006	Left Conical gear Z=37	1	143,00
11	3.004.0007	Right Conical gear Z=23	1	99,00
12	4.003.0019	Arm Pin D32 L=240	1	7,70
13	3.014.0008	Crossbar shaft drum mower	1	99,00
14	4.006.0004	Crossbar drum mower 180	1	231,00
15	2.002.0055	Self locking Nut ISO 7040 UNI 7473 M20	1	1,10
16	2.003.0038	Wide Flat Washer ISO 7093/2 D20	1	1,10
17	3.012.0150	Locking tilting plate for cutting bar	1	6,60
18	2.001.0087	Hex. Screw ISO 4017 M12x35	18	1,10
19	2.003.0056	Split Washer DIN 127B UNI 1751 D12	24	1,10
20	2.002.0051	Self locking Nut ISO 7040 UNI 7473 M12	1	2,20
21	2.010.0012	PTO guard	1	36,30
22	2.003.0003	Flat Washer ISO 7089 D6	4	1,10
23	2.001.0019	Hex. Screw ISO 4017 M6x16	4	1,10
24	3.025.0004	Sealing washer	4	8,80
25	2.022.0003	Key DIN 6885 - A 10 x 8 x 40	2	1,10
26	3.007.0022	Spacer 44,5-35-5	1	2,75
27	2.021.0002	Seeger ring for shaft DIN 471- 35x1,5	1	6,60
28	2.003.0013	Flat Washer ISO 7089 D27	1	1,10
29	2.002.0081	Self locking Nut thin ISO 10511 fine pitch thread M27x2	1	4,95
30	2.001.0085	Hex. Screw ISO 4017 M12x25	6	1,10
31	2.003.0006	Flat Washer ISO 7089 D12	2	1,10
32	2.001.0088	Hex. Screw ISO 4017 M12x40	1	1,10

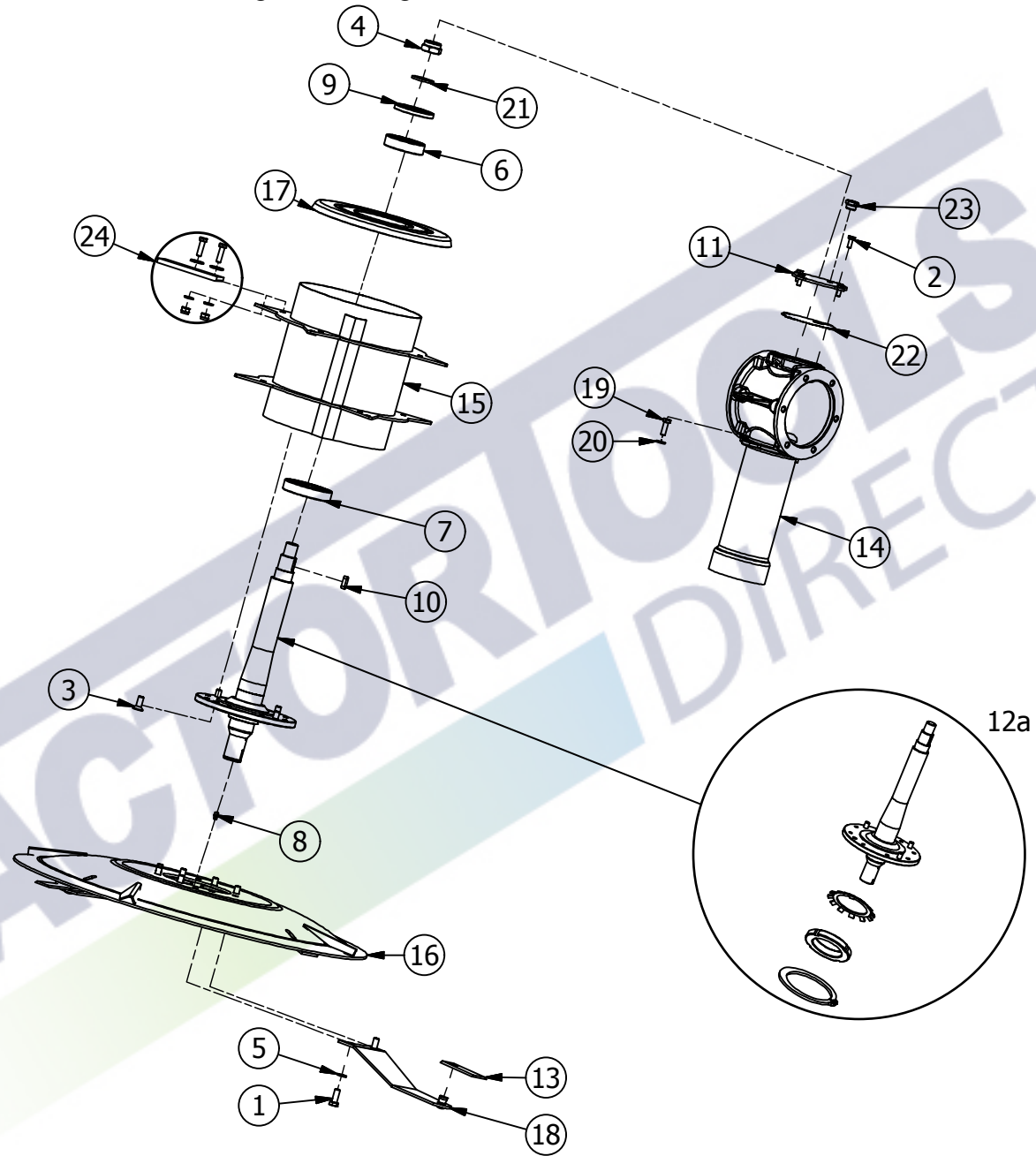



## Right drum gearbox for drum mower 180

Cod. 5.010.0010

Pos.	Code	Description	Quantity	Net Price \$
1	2.001.0086	Hex. Screw ISO 4017 M12x30	8	1,10
2	2.001.0040	Hex. Screw ISO 4017 M8x20	4	1,10
3	2.001.0647	Socket Cap Screw ISO 10642 M12x30	4	1,10
4	2.002.0103	Self locking Nut thin UNI 7474 fine pitch thread M27x2	1	4,95
5	2.003.0056	Split Washer DIN 127B UNI 1751 D12	8	1,10
6	2.004.0005	Roller bushing 6308 2RSR	1	60,50
7	2.004.0006	Roller bushing 6212 2RSR	1	82,50
8	2.013.0002	Greaser DIN 71412 -A M8x1,25	1	1,65
9	2.020.0002	Sealing ring DIN 3760 - AS - 90 x 55 x 10 -NBR	1	5,50
10	2.022.0001	Key DIN 6885 - A 10 x 8 x 28	1	1,10
11	3.012.0001	Plate	1	16,50
12a	4.013.0001	Right shaft kit: shaft drum mower - Right hand thread + 4.013.0003 (6a pag. 23)	1	308,00
13	3.016.0001	Cutting blade drum mower	4	2,20
14	3.024.0001	Drum casting	1	220,00
15	4.004.0003	Drum for mower 180	1	115,50
16	4.009.0013	Upper Right disc bar mower 180	1	198,00
17	4.009.0004	Upper flange bar mower	1	38,50
18	4.010.0004	Leaf spring	4	27,50
19	2.001.0062	Hex. Screw ISO 4017 M10x30	2	1,10
20	2.003.0005	Flat Washer ISO 7089 D10	2	1,10
21	2.003.0013	Flat Washer ISO 7089 D27	1	1,10
22	3.025.0001	Sealing washer	1	8,80
23	2.015.0010	Oil fill plug	1	5,50
24	4.013.0019	Optional kit flail blade drum mower 180	2	5,50

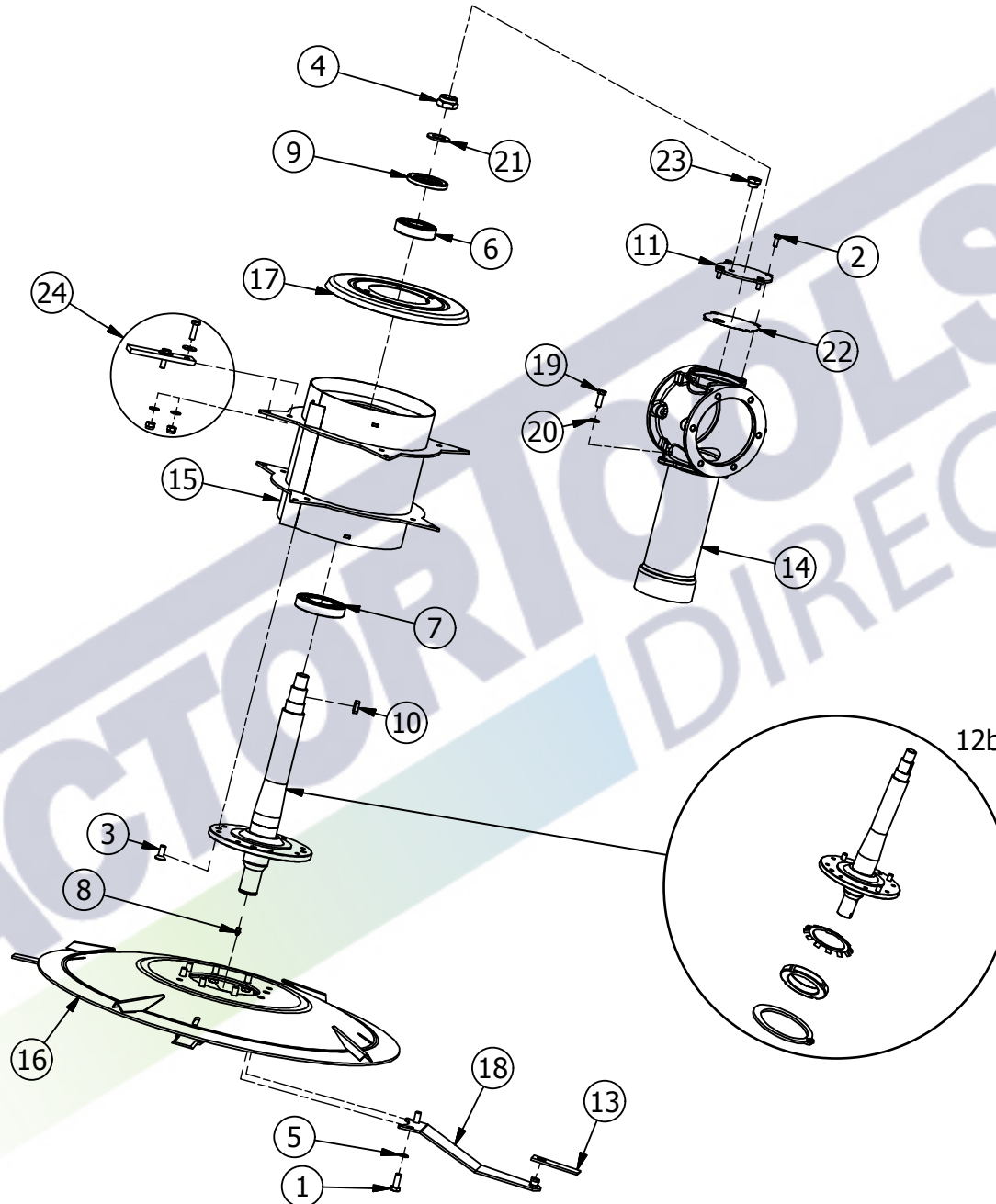

## Left drum gearbox for drum mower 180

Cod. 5.010.0009

Pos.	Code	Description	Quantity	Net Price \$
1	2.001.0086	Hex. Screw ISO 4017 M12x30	8	1,10
2	2.001.0040	Hex. Screw ISO 4017 M8x20	4	1,10
3	2.001.0647	Socket Cap Screw ISO 10642 M12x30	4	1,10
4	2.002.0103	Self locking Nut thin UNI 7474 fine pitch thread M27x2	1	4,95
5	2.003.0056	Split Washer DIN 127B UNI 1751 D12	8	1,10
6	2.004.0005	Roller bushing 6308 2RSR	1	60,50
7	2.004.0006	Roller bushing 6212 2RSR	1	82,50
8	2.013.0002	Greaser DIN 71412 -A M8x1,25	1	1,65
9	2.020.0002	Sealing ring DIN 3760 - AS - 90 x 55 x 10 -NBR	1	5,50
10	2.022.0001	Key DIN 6885 - A 10 x 8 x 28	1	1,10
11	3.012.0001	Plate	1	16,50
12b	4.013.0002	<u>Left shaft kit: shaft drum mower - Left hand thread + 4.013.0004 (6b pag. 25)</u>	1	308,00
13	3.016.0001	Cutting blade drum mower	4	2,20
14	3.024.0001	Drum casting	1	220,00
15	4.004.0003	Drum for mower 180	1	115,50
16	4.009.0014	Upper Left disc bar mower 180	1	198,00
17	4.009.0004	Upper flange bar mower	1	38,50
18	4.010.0004	Leaf spring	4	27,50
19	2.001.0062	Hex. Screw ISO 4017 M10x30	2	1,10
20	2.003.0005	Flat Washer ISO 7089 D10	2	1,10
21	2.003.0013	Flat Washer ISO 7089 D27	1	1,10
22	3.025.0001	Sealing washer	1	8,80
23	2.015.0010	Oil fill plug	1	5,50
24	4.013.0019	Optional kit flail blade drum mower 180	2	5,50

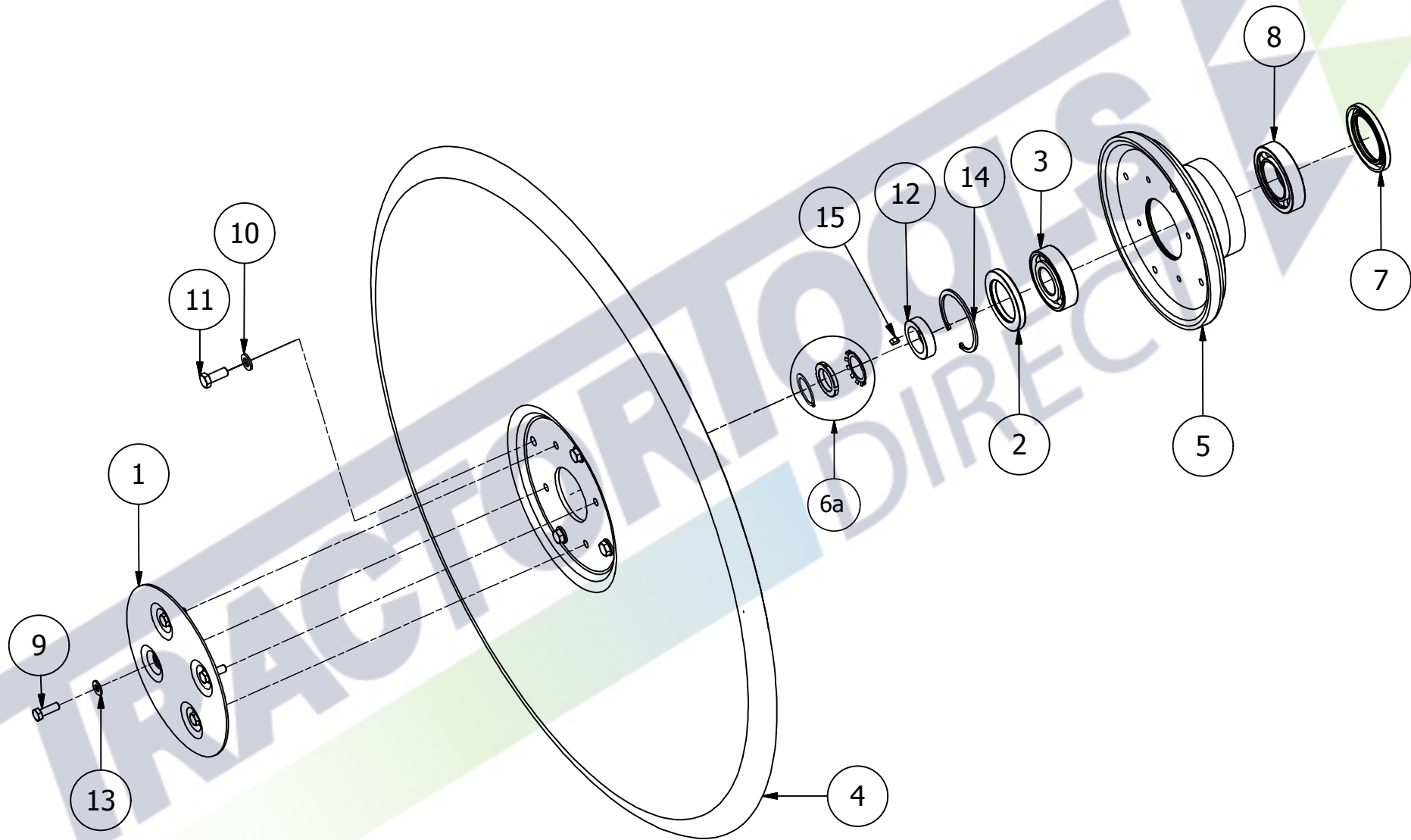



## Right lower disc group

Cod. 5.010.0016

Pos.	Code	Description	Quantity	Net Price \$
1	3.001.0010	Cap for lower disc	1	55,00
2	2.020.0003	Sealing ring DIN 3760 - A - 58 x 90 x 10	1	8,80
3	2.004.0007	Conical Roller bushing 7308B TVP. UA (40-90-23)	1	93,50
4	3.001.0012	Lower disc - bar mower 185	1	198,00
5	3.008.0031	Support flange	1	137,50
6a	4.013.0003	Safety washer + Right ring nut M40 x 1.5 + Seeger ring for shaft DIN 471- 40x1,75	1	11,00
7	2.020.0006	Sealing ring DIN 3760 - A - 68 x 100 x 10	1	8,80
8	2.004.0016	Conical Roller bushing 7211B TVP. UA (55-100-21)	1	97,90
9	2.001.0062	Hex. Screw ISO 4017 M10x30	4	1,10
10	2.003.0006	Flat Washer ISO 7089 D12	4	1,10
11	2.001.0086	Hex. Screw ISO 4017 M12x30	4	1,10
12	3.008.0005	Spacer	1	9,90
13	2.003.0005	Flat Washer ISO 7089 D10	4	1,10
14	2.021.0003	Seeger ring for holes DIN 472 -90X3	1	6,60
15	2.022.0009	Key DIN 6885 - A 6x6 x12	1	1,10

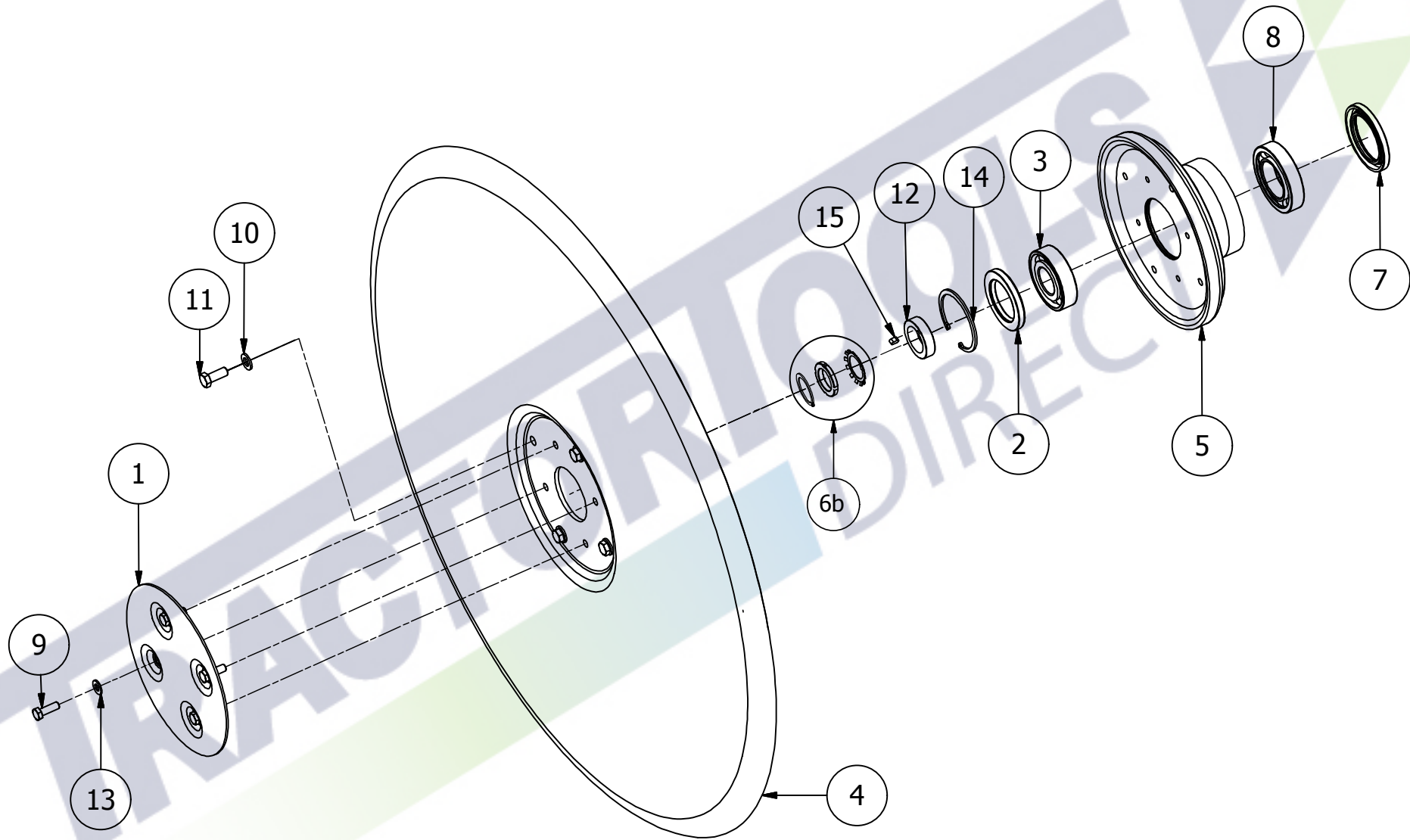

## Left lower disc group

Cod. 5.010.0021

Pos.	Code	Description	Quantity	Net Price \$
1	3.001.0010	Cap for lower disc	1	55,00
2	2.020.0003	Sealing ring DIN 3760 - A - 58 x 90 x 10	1	8,80
3	2.004.0007	Conical Roller bushing 7308B TVP. UA (40-90-23)	1	93,50
4	3.001.0012	Lower disc - bar mower 185	1	198,00
5	3.008.0031	Support flange	1	137,50
6b	4.013.0004	Safety washer + Left ring nut M40x 1.5 + Seeger ring for shaft DIN 471- 40x1,75	1	11,00
7	2.020.0006	Sealing ring DIN 3760 - A - 68 x 100 x 10	1	8,80
8	2.004.0016	Conical Roller bushing 7211B TVP. UA (55-100-21)	1	97,90
9	2.001.0062	Hex. Screw ISO 4017 M10x30	4	1,10
10	2.003.0006	Flat Washer ISO 7089 D12	4	1,10
11	2.001.0086	Hex. Screw ISO 4017 M12x30	4	1,10
12	3.008.0005	Spacer	1	9,90
13	2.003.0005	Flat Washer ISO 7089 D10	4	1,10
14	2.021.0003	Seeger ring for holes DIN 472 -90X3	1	6,60
15	2.022.0009	Key DIN 6885 - A 6x6 x12	1	1,10

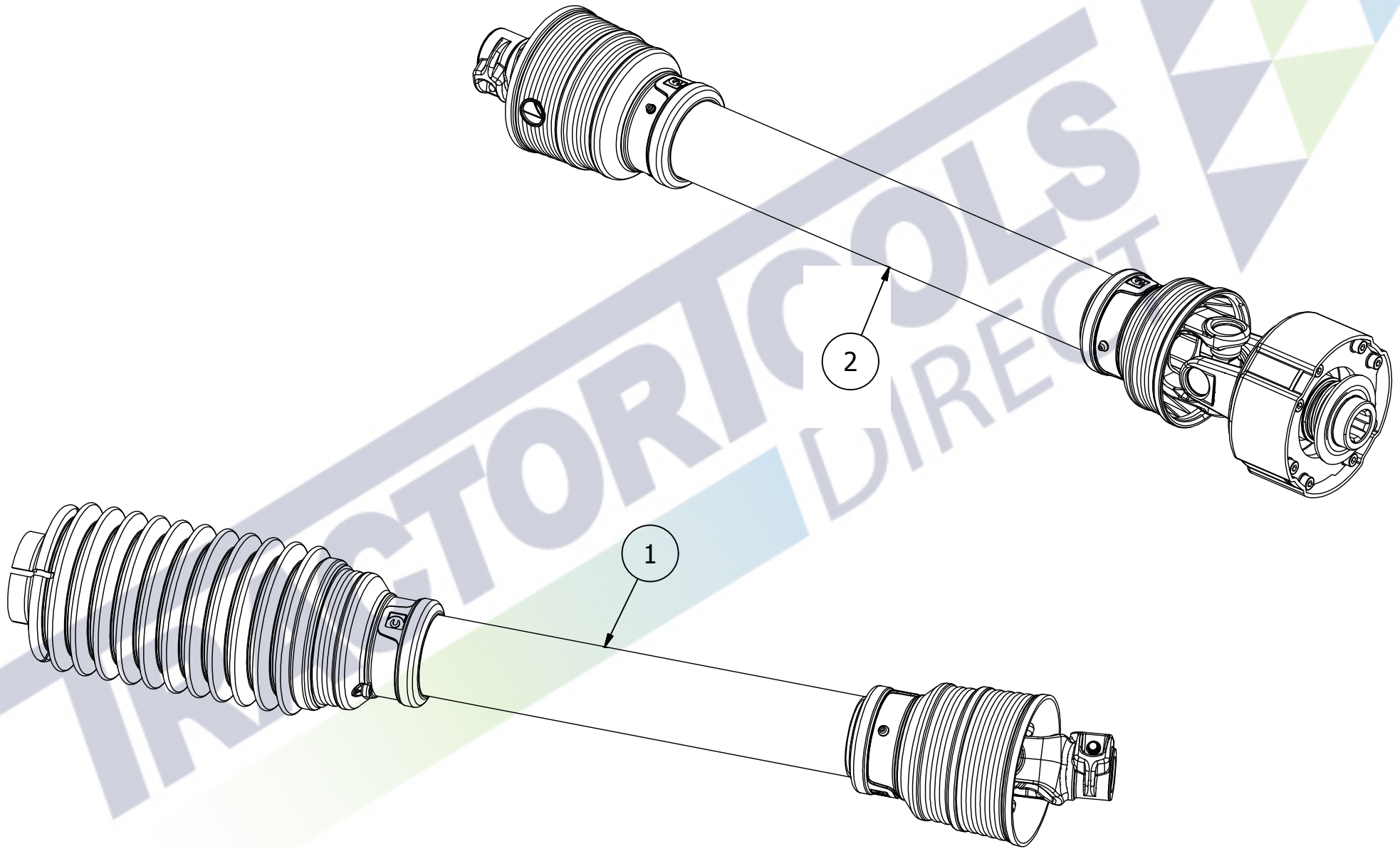



# PTO shaft

Cod. 5.016.0013/0015

Pos.	Code	Description	Quantity	Net Price \$
1	5.016.0013	Intermediate PTO shaft	1	198,00
2	5.016.0015	PTO shaft	1	242,00

TRACTORTOOLS  
DIRECT

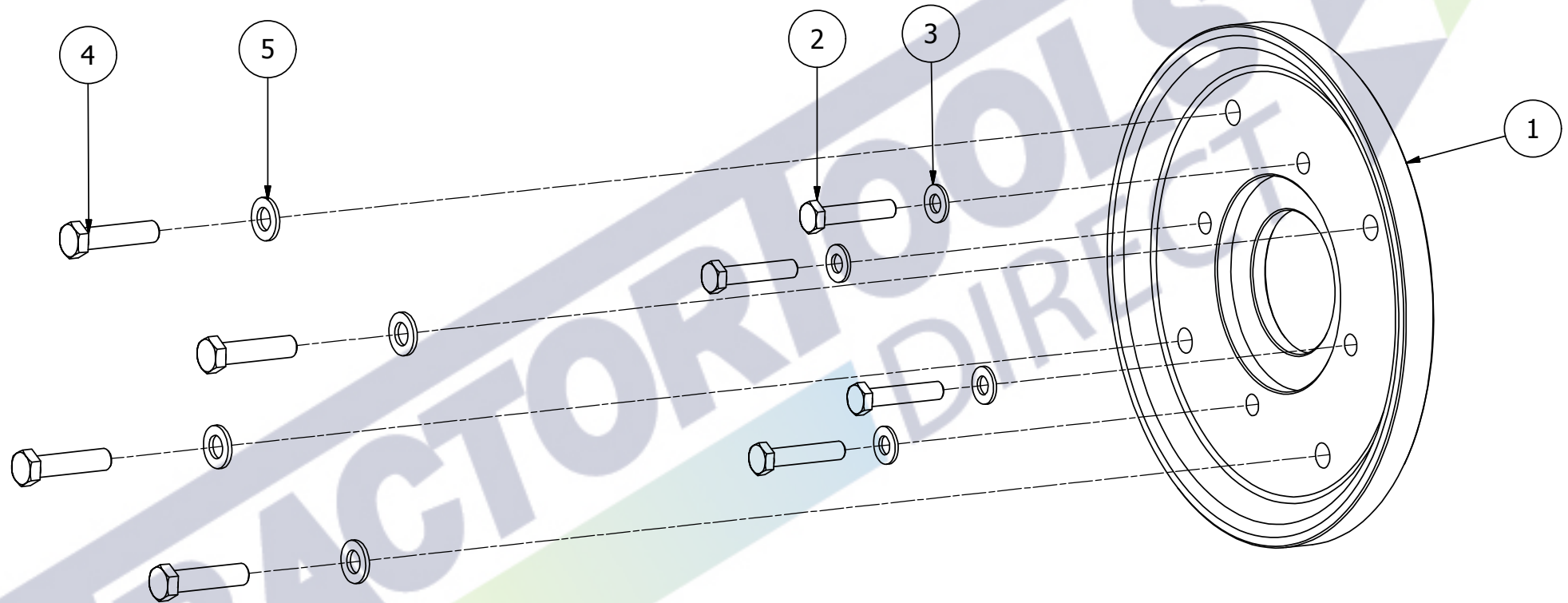

## Optional lift kit

Cod. 4.013.0005

Pos.	Code	Description	Quantity	Net Price \$
1	3.008.0035	Flange H=20mm	2	
2	2.001.0066	Hex. screw ISO 4017 M10x50	8	
3	2.003.0005	Flat washer ISO 7089 D10	8	120,00
4	2.001.0090	Hex. screw ISO 4017 M12x50	8	
5	2.003.0006	Flat washer ISO 7089 D12	8	

TRACTORTOOLS  
DIRECT



**MAINTENANCE-REPAIR AND OPERATING HAND BOOK**  
OPERATING MANUAL SPARE PARTS CATALOGUE



**CONTACT**

service@terra-implements.it  
tel. +39 0171 4142  
www.terra-implements.it  
ITALY