

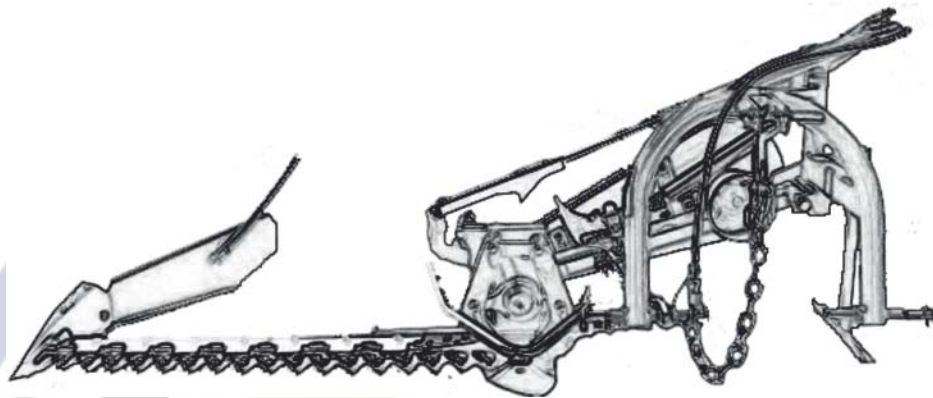

Operator's Manual

SICKLE BAR MOWERS

BF MJ 105 – BF MJ 120 – BF MJ 135 - BF MJ 150



The operator's manual is a technical service guide and must always accompany the machine.

SAFETY

Take note! This safety alert symbol found throughout this manual is used to call your attention to instructions involving your personal safety and the safety of others. Failure to follow these instructions can result in injury or death.



*This symbol means:
ATTENTION!
BECOME ALERT!
YOUR SAFETY IS INVOLVED!*

Signal Words

Note the use of the signal words DANGER, WARNING and CAUTION with the safety messages. The appropriate signal words for each have been selected using the following guidelines:



DANGER: Indicates an imminently hazardous situation that, if not avoided, will result in death or serious injury.



WARNING: Indicates a potentially hazardous situation that, if not avoided, could result in death or serious injury, and includes hazards that are exposed when guards are removed. It may also be used to alert against unsafe practices.



CAUTION: Indicates a potentially hazardous situation that, if not avoided, may result in minor or moderate injury.

1 - GENERAL INFORMATION

Thank you and congratulations for having chosen our implement. Your new sickle bar mower is a technologically advanced machine constructed of high quality, sturdy components that will fulfill your working expectations. Read this manual carefully. It will instruct you on how to operate and service your implement safely and correctly. Failure to do so could result in personal injury and/or in equipment damage.

1.01 – General

The implement described in this manual is to be used with tractors with PTO at 540 rpm and clockwise rotation.



CAUTION: Always ensure that the coupling of the implement with the tractor is done at the same PTO speed and direction of rotation. Do not operate this implement at a PTO speed or direction of rotation other than that shown on the implement. Serious damage can occur to the machine and/or the operator.



CAUTION: Unless otherwise specified, all hardware is metric. Use only metric tools on metric hardware. Other tools that do not fit properly can slip and cause injury.



CAUTION: Right hand and left hand sides of the implement are determined by facing in the direction the implement will travel when going forward (see fig. 7).

Carefully read the Warranty section (See Chapter 8 - Warranty), detailing coverage and limitations of this warranty.

Warranty is provided for customers who operate and maintain their equipment as described in this manual. Warranty registration is accomplished by the dealer by completing and forwarding the **Warranty Registration** form to the Company, along with a copy of the dealer's invoice. It is in your best interest to insure that this has been done.

Warranty does not cover the following:

1. Cleaning, transporting, mailing and service call charges.
2. Normal wear items such as belts, blades, bearings, drivelines, shear pins, slip clutches, etc.
3. Depreciation or damage caused by normal wear, accidents, improper maintenance, improper protection or improper use.
4. The use of non-original spare parts and accessories.

Your Authorized Company Dealer has genuine parts in stock. Only these approved replacement parts should be used.

This limited warranty covers defective material and workmanship. The cost of normal maintenance or repairs for accidents or improper use and related labor will be borne by the owner.

1.02 - Model and Serial Number ID

Attached to the frame is an ID plate showing the model and the serial number. Record your implement model and serial number in the space provided below. Your dealer needs this information to give you prompt, efficient service when you order parts.



1.03 - Assembly Instructions



CAUTION: Stand clear of bands when cutting as they could be under sufficient tension to cause them to fly loose. Take care in removing bands and wire. They often have extremely sharp edges and cut very easily.

For transport purposes implements are often shipped partially assembled. Follow the instructions below to assemble the sickle bar mower BF MJ.

To assemble the support stand (see fig. 2):

1. Remove the pin from the support stand.
2. Move the support stand.

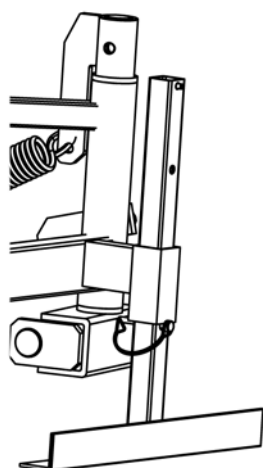

Position of transport

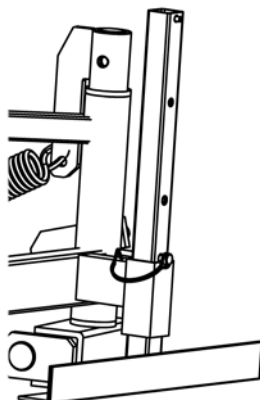

Position of work

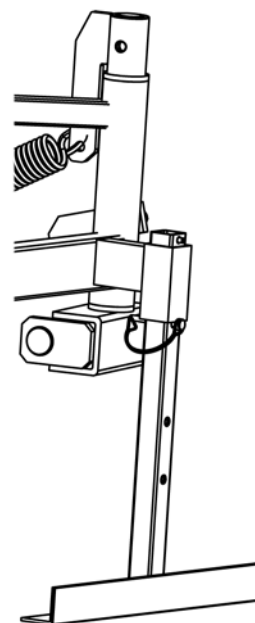

Parking position.

fig.2

To install the spring (see Fig. 3)

1. Attach one side of the spring to the attachment.
2. Fix in the other side of the spring the eye bolt.
3. Put the eye bolt in the hole of the frame bar and fix with the elastic stop nut M12.

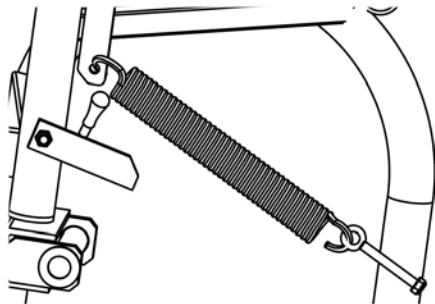

Fig.3

To assemble the safety release (see Fig. 4):

1. Put the safety release to the pin of the 3rd point and the other side to the pin of frame bar.
2. Fix the 2 pin with the roll pins (D6X50).

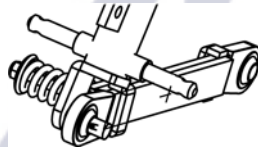

Fig.4

To assemble the hydraulic lift system:

1. Remove the hex head bolt (M12X65) from the cylinder stop bracket mounted over the cylinder
2. Insert the cylinder rod to the cylinder attachment, insert the galvanized pin and fix with the roll pins (D6X50).
3. Lay the cylinder stop bracket over the lift point lever and align the holes.
4. Insert the hex head bolt M12X65 through the hole on the cylinder stop bracket, the slotted lift point lever and the cylinder rod.
5. Use the elastic stop nut M12 to tighten making sure to leave enough slack for the cylinder stop bracket to move freely.

To assemble the mechanical lift system:

1. Fix the 2 lever to the lower 3rd point attachment (left side) with the 2 bolts and nuts and the spacer tube.
2. Put the balance lever to the pin of the frame bar and fix with the roll pins D6X50.
3. Fix the 2 chains to the lever, the balance lever and the extension bar with the 4 shackles; the adjustment of the length of the chains changes the lifting of the machine and of outer bar support.

To install the blade and shoe (see fig. 6):

1. Place the black internal skid shoe on the floor.
2. Remove the elastic stop nuts (M14) and let the bolts (M14) sit up straight.
3. Position the complete cutting bar section over the internal skid shoe and fit the four bolts through the corresponding holes on the blade support bar.
4. Remove the conic bolts and jam nuts (M12) from the blade section and teeth bar (**see fig. 6**).

5. Position the sickle bar frame by the cutting bar section so that the bolts (M14) can be assembled through the support frame and the connecting rod assembly is positioned over the blade section and teeth bar.
6. Position the galvanized connector protection cover with the welded brackets so that the side bracket fits through the counter sunk bolt (M14x70) and the front bracket fits through the carriage bolt (M10x40) mounted on the front of the internal skid shoe.
7. Use the elastic stop nut (M10) to securely tighten the carriage bolt (M10x40) on the front internal skid shoe.
8. Use the elastic stop nuts (M14) to securely tighten the four bolts M14.
9. Assemble the hex head bolt (M14x45) and elastic stop nut (M14) on the fifth hole found on the edge of the large support frame and tighten it securely.
10. Using the conic bolts, assemble the teeth bar and blade section to the corresponding blade bar arm. Using a torque wrench, tighten conic bolts to 95 ft-lb. Secure them using the jam nuts (M12).

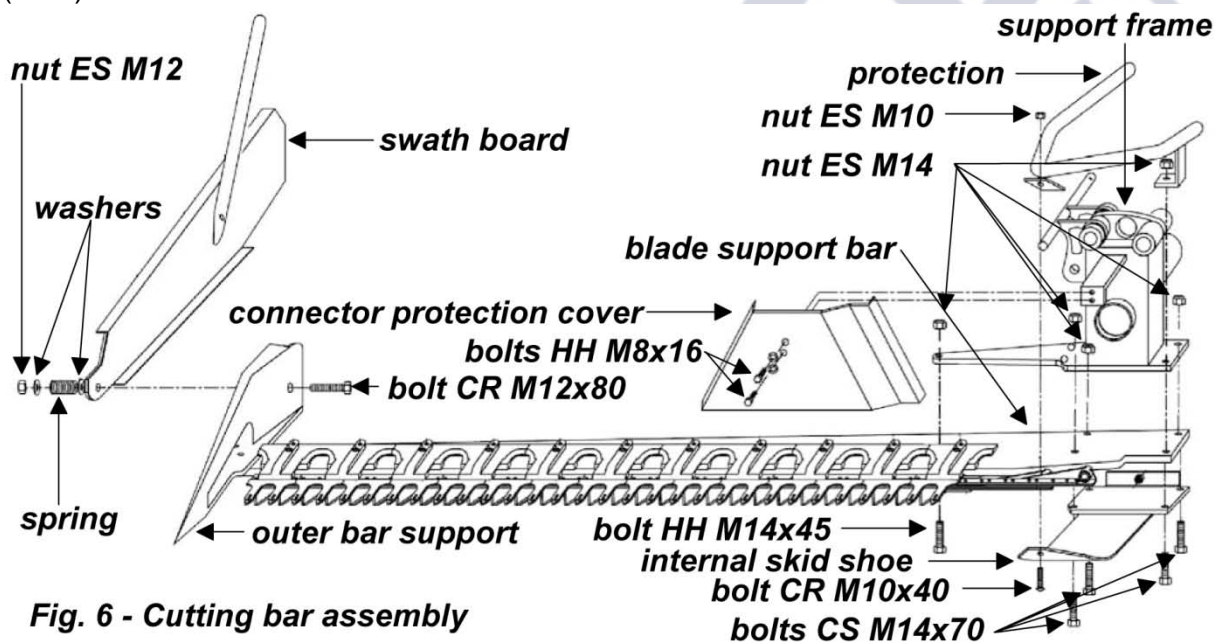

Fig. 6 - Cutting bar assembly

To install the connector protection cover (see fig. 6):

1. Remove the two hex head bolts (M8x16) and the two washers ($\text{Ø}8 \times 24 \times 2$) bolted on the large support frame.
2. Position the connector protection cover making sure to align the holes on the cover to the holes on the support frame.
3. Assemble using the two hex head bolts (M8x16) and the two washers ($\text{Ø}8 \times 24 \times 2$) and tighten securely.

To install the swath board (see fig. 6):

1. Remove the carriage bolt (M12x80) and spring from the swath board.
2. Position the swath board against the outer bar support.
3. Align the holes and insert the carriage bolt (M12x80) through the hole on the outer support bar and through the hole on the swath board.
4. Insert the first washer ($\text{Ø}12 \times 24 \times 2.5$), the spring and the second washer ($\text{Ø}12 \times 24 \times 2.5$) through the carriage bolt (M12x80).
5. Use the elastic stop nut (M12) to tighten securely.

2 - SAFETY PRECAUTIONS

Safety is the primary concern in the design and manufacture of our products. Unfortunately our efforts to provide safe equipment can be wiped out by a single careless act of an operator. In addition to the design and configuration of equipment, hazard control and accident prevention are dependent upon the awareness, concern, prudence and proper training of personnel involved in the operation, transport, maintenance and storage of equipment. It is the operator's responsibility to read and understand all safety and operating instructions in the manual and to follow these. Allow only properly trained personnel to operate the implement. Working with unfamiliar equipment can lead to careless injuries. Read this manual, and the manual for your tractor, before assembly or operation, to acquaint yourself with the machines. It is the owner's responsibility, if this machine is used by any person other than yourself, is loaned or rented, to make certain that the operator, prior to operating, reads and understands the operator's manuals and is instructed in safe and proper use.

2.01 - Preparation



1. Before operating equipment read and understand the operator's manual and the safety signs (see fig. 7).
2. Thoroughly inspect the implement before initial operation to assure that all packaging materials, i.e. wires, bands, and tape have been removed.
3. Personal protection equipment including hard hat, safety glasses, safety shoes, and gloves are recommended during assembly, installation, operation, adjustment, maintaining and/or repairing the implement.
4. Operate the implement only with a tractor equipped with an approved Roll-Over-Protective-System (ROPS). Always wear your seat belt. Serious injury or even death could result from falling off the tractor.
5. Clear area to be cut of stones, branches or other debris that might be thrown, causing injury or damage.
6. Operate only in daylight or good artificial light.
7. Ensure implement is properly mounted, adjusted and in good operating condition.
8. Ensure that all safety decals are properly installed and in good condition.

2.02 - Starting and Stopping



1. Be sure that no one is near the machine prior to engaging or while the machine is working.
2. Be sure the tractor is in "Neutral" before starting engine.
3. Never use the lifting controls when standing between the tractor and linkage.
4. Mower operating power is supplied from tractor PTO. Refer to your tractor manual for PTO engagement and disengagement instructions. Always operate PTO at 540 rpm. Know how to stop the tractor and mower quickly in case of an emergency.
5. When engaging PTO, the engine rpm should always be low. Once engaged and ready to start cutting, raise PTO speed to 540 rpm and maintain throughout cutting operation.
6. Check the tractor master shield over the PTO stub shaft. Make sure it is in good condition and fastened securely to the tractor. Purchase a new shield if old shield is damaged or missing.
7. After striking an obstacle, disengage the PTO, shut the tractor down and thoroughly inspect for damage before restarting.

8. Never engage the PTO until the mower is in the down position and resting on the ground. Never raise the mower until all blades have come to a complete stop.
9. To park the vehicle safely, stop vehicle on a level surface (not on a slope), disengage PTO, engage the parking brake, stop the engine, remove the key, and wait for engine and all moving parts to stop before leaving the operator's seat.
10. Stay clear of rotating drivelines. Entanglement in rotating driveline can cause serious injury or death. Wear close fitting clothing. Stop the engine and be sure PTO driveline is stopped before getting near it.

2.03 - Messages and Signs



1. Read and adhere to all safety and operating decals on this machine (**see fig. 7**).
 2. Before dismounting tractor: Allow moving parts to stop, stop engine, set brake and remove the key of unattended equipment.
 3. Keep safety decals in place and in good condition.
 4. Keep guards and shields in place and in good condition.
 5. Do not use with bystanders in area.
 6. Allow no riders on tractor or implement.
 7. Allow moving parts to stop before repair.
 8. Securely support implement before working underneath.
- Additional warning and operating decals are available at no extra charge. Please specify model and serial number when ordering.

Fig. 7 - Safety decals - implement; replace immediately if damaged.

⚠ WARNING

High-pressure hydraulic oil leaks can penetrate skin resulting in serious injury, gangrene or death.

- Check for leaks with cardboard; never use hand.
- Before loosening fittings: lower load, release pressure, and be sure oil is cool.
- Consult physician immediately if skin penetration occurs.

950-4098

⚠ DANGER

Avoid injury from PTO

- Entanglement can cause serious injury or death.
- Keep driveline shields in place & in good condition.
- Keep hands, feet and clothing away.
- Operate only with 540 RPM.

950-1098

⚠ DANGER

Keep away sharp blades

- Do not put hands or feet near the cutterbar. Blade contact can result in serious injury.
- Stay away until all motion has stopped and the mower is securely blocked up.
- Keep fingers clear of cutterbar when folding cutterbar for transport.

950-9508

⚠ WARNING

Crushing and Pinching Hazard

- Be extremely careful handling various parts of the hitching mechanism. They are heavy and hands, fingers, feet, and other body parts could be crushed or pinched between tractor and implement.
- Operate tractor controls from tractor seat only.
- Do not stand between tractor and implement when tractor is in gear.
- Make sure parking brake is engaged before going between tractor and implement.
- Stand clear of machine while in operation or when it is being raised or lowered.

Failure to follow these instructions could result in serious injury or death.

950-4078

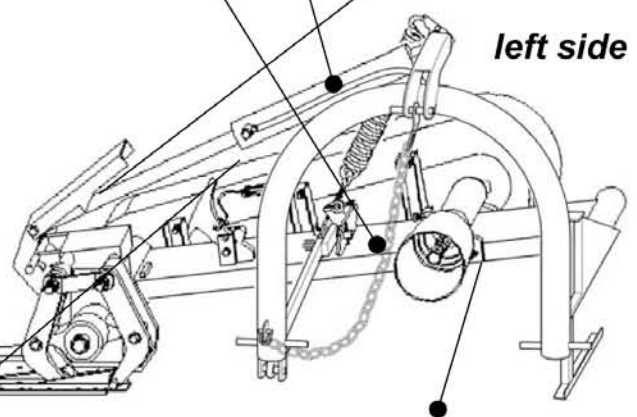
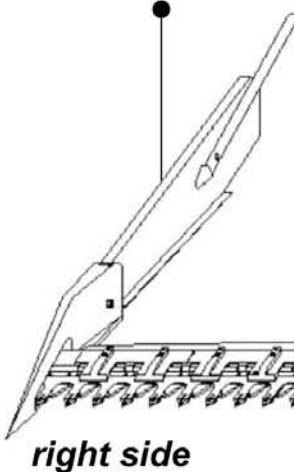

⚠ DANGER

Replace shields before using machine

950-2138

⚠ CAUTION

To avoid serious injury:

- Read Operator's Manual before operating, servicing or repairing equipment. Follow all safety rules and instructions. (Manuals are available from your selling dealer).
- Know location and function of controls.
- Keep all shields in place and in good condition.
- Stay clear of power driven parts.
- Never allow riders.
- Never allow children or untrained persons to operate equipment.
- Keep bystanders at a safe distance away from mower during operation.
- Before mowing, clear area of objects that may be thrown by blades.
- Use extra caution on uneven terrain. Decrease speed when turning.
- Tractor must be equipped with a Roll-Over-Protection-System (ROPS) and seatbelt.
- Keep foldable ROPS systems in the "locked up" position at all times.
- Keep seatbelt securely fastened.

Before dismounting or servicing

- Shut off engine and remove key.
- Lock parking brake.
- Wait for all movement to stop
- Lower or block up mower.

950-1118

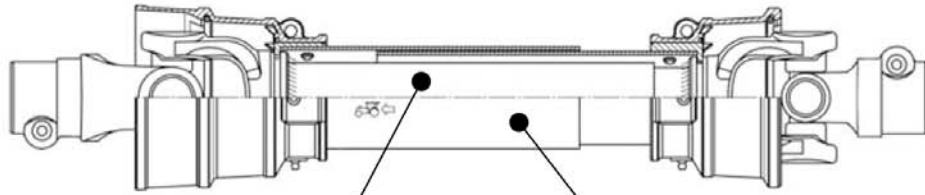

placed on outer tube



placed on outer shield

3 - OPERATION

You have purchased a sickle bar mower designed for the mowing of fields, ditch banks and along ponds. The sickle bar mowers can be used with tractors from 16 up to 75 HP and come in working widths of 105, 120, 135 and 150 cm. The double action sickle bar mowers come complete with an adjustable top link that ensures a sharp clean cut. The double action sickle bar allows for a maximum working speed of up to 6.5 mph. Simple but tough construction along with a heavy duty PTO, weight compensation spring, transport blade protection and a safety release which protects the unit from obstructions in the field, all provide for a unit that will give years of trouble free service. Sickle bar mowers come standard with a hydraulic cylinder that makes it easy to raise the bar for mowing at an angle or for transport and storage. With the capability of mowing 90° up -25° down along with the low horsepower requirements make the sickle bars capable of handling jobs that are not recommended for conventional disc mowers.



WARNING: The sickle bar is suitable only for the uses indicated. Any other use different from that described in these instructions could cause damage to the machine and represent a serious hazard for the user.

3.01 - Operational Safety



CAUTION: Our mowers are designed considering safety as the most important aspect and are the safest available in today's market. Unfortunately, human carelessness can override the safety features built into our machines. Injury prevention and work safety, aside from the features on our mowers, are very much due to the responsible use of the equipment. It must always be operated prudently following with great care, the safety instructions laid out in this manual.



1. The use of this equipment is subject to certain hazards which cannot be prevented by mechanical means or product design. All operators of this equipment must read and understand this entire manual, paying particular attention to safety and operating instructions, prior to using.
2. Do not operate the tractor and implement when you are tired, sick or when using medication.
3. Keep all helpers and bystanders at least 50 feet from the implement. Only properly trained people should operate this machine.
4. Accidents are most likely to occur with machines that are loaned or rented to someone who has not read the operator's manual and is not familiar with the implement.
5. The majority of accidents involve entanglements on the driveline, injury of bystanders by objects thrown by the rotating blades, and operators being knocked off the tractor by low hanging limbs and then being run over by the mower. Accidents are most likely to occur with machines that are loaned or rented to someone who has not read the operator's manual and is not familiar with a rotary mower.
6. Always stop the tractor, set brake, shut off the tractor engine, remove the ignition key, lower implement to the ground and allow mower blades to come to a complete stop before dismounting tractor. Never leave equipment unattended with the tractor running.

7. Never place hands or feet under mower with tractor engine running or before you are sure all motion has stopped. Stay clear of all moving parts.
8. Do not allow riders on the mower or tractor at any time. There is no safe place for riders.
9. Do not operate unless all personnel, livestock and pets are several feet away to prevent injury by thrown objects.
10. Before backing up, disengage the mower and look behind carefully.
11. Install and secure all guards and shields before starting or operating
12. Keep hands, feet, hair and clothing away from moving parts.
13. This mower is designed for use only on tractors with 540 rpm power take off.
14. Never operate tractor and mower under trees with low hanging limbs. Operators can be knocked off the tractor and then run over by the rotating blades.
15. The rotating parts of this machine have been designed and tested for rugged use. However, they could fail upon impact with heavy, solid objects such as steel guard rails and concrete abutments. Such impact could cause the broken objects to be thrown outward at very high velocities. To reduce the possibility of property damage, serious injury, or even death, never allow the cutting blades to contact such obstacles.
16. Frequently check mower blades. They should be sharp, free of nicks and cracks and securely fastened.
17. Stop mower immediately upon striking an obstruction. Turn engine off, remove key, inspect and repair any damage before resuming operation.
18. Stay alert for holes, rocks and roots in the terrain and other hidden hazards. Keep away from drop-offs.
19. Use extreme care and maintain minimum ground speed when transporting on hillside, over rough ground and when operating close to ditches or fences. Be careful when turning sharp corners.
20. Reduce speed on slopes and sharp turns to minimize tipping or loss of control. Be careful when changing directions on slopes. Do not start or stop suddenly on slopes. Avoid operation on steep slopes.
21. When using a unit, a minimum 20% of tractor and equipment weight must be on tractor front wheels. Without this weight, tractor could tip over, causing personal injury or death. The weight may be attained with a front end loader, front wheel weights, ballast in tires or front tractor weights. When attaining a minimum 20% of tractor and equipment weight on the front wheels, you must not exceed the ROPS weight certification. Weigh the tractor and equipment. Do not guess or estimate!
22. Inspect the entire machine periodically (see Chapter 5 – Maintenance). Look for loose fasteners, worn or broken parts, and leaky or loose fittings.
23. Use only the driveline supplied with the mower. Do not use it if it is missing any shield or safety protection.
24. Pass diagonally through sharp dips and avoid sharp drops to prevent “hanging up” tractor and mower.
25. Avoid sudden starts and stops while traveling up or downhill.
26. Always cut down slopes; never across the face. Avoid operation on steep slopes. Slow down on sharp turns and slopes to prevent tipping and or loss of control.

3.02 - Setup

Notice to dealer: Pre-delivery setup and service including lubrication is the responsibility of the authorized dealer. It is up to him to assure that the machine is in perfect condition and ready to be used. It is his responsibility to ensure that the customer is aware of all safety aspects and operational procedures for the mower. He must also fill out the Pre-Delivery Checklist (See Chapter 7 - Pre-Delivery Checklist) prior to delivering the mower.

3.03 - Pre-Operational Check

IMPORTANT: Check each of the following, carefully, prior to engaging the equipment:

1. All lubrication points have been greased.
2. The belts for proper tension.
3. The driveline cross and bearings have been greased.
4. No wrappings or foreign objects are around the blades, belts or driveline.
5. The blades are properly installed.
6. All hardware is tight.
7. The tractor, to ensure correct direction of PTO and rpm speed.
8. All safety shields and guards are in place and tightly attached.
9. No people or animals are in the work area.
10. When working, make sure the tractor hitch is in the "float" position, in order to allow the mower to follow the contour of the ground.



DANGER: Stay clear of rotating driveline. Entanglement in rotating driveline can cause serious injury. Disengage PTO, engage parking brake or place transmission in "Park", shut off the tractor and remove the key before working around hitch, attaching or detaching driveline, making adjustments, servicing or cleaning the machine.

3.04 - Attaching to the Tractor

Models BF MJ may be used on tractors ranging from 16 to 40 HP. All models should be used on tractors equipped with a standard PTO and a category 1.

Never use this mower with tractors over 75 HP.



DANGER: The lever that you can see on the left of the picture 3 is to fix the position during the parking of the machine. During the work the lever **MUST** be unlocked. During the parking the lever must be fixed to the frame bar and the 3rd point will be in position when you will attach the machine to the 3rd point.



CAUTION: Check the tractor PTO rpm to ensure it is set at 540 and turns clockwise.



CAUTION: Always ensure that the tractor tire pressure is correct according to the tractor operator's manual.



DANGER: Failure to ensure a secure coupling of the implement to the tractor can cause injury and damage to the implement or tractor.

To attach the sickle bar to the tractor do the following:

Remove lower hitch pins and back tractor up to implement. Once in position set parking brake, shut off engine, and remove key before dismounting to attach implement. Slide lower hitch arms of the tractor between the plates of the lower hitch. Replace lower hitch pins and secure with lynch pin. Attach top link of the tractor to the top of the "A" frame of the implement. Adjust the tractors tie-rods to prevent implement from swinging side to side. Install PTO shaft to tractor and make sure shaft is locked on the tractor PTO prior to engagement. Check that PTO shaft guard is free to turn and secure it with the relative latches. Remove the guard over the cutting blades. Raise sickle bar. Remove the pin that retains the support stand, turn the support stand upside down and reassemble it on the frame securing it with the pin.

IMPORTANT: See Section 4.03 - Driveline, to ensure the driveline is the proper length.

3.05 - Start Up



DANGER: The mower must always be lowered to the ground before starting tractor engine or engaging PTO lever. It is forbidden to stand between the tractor and linkage to operate the lifting controls of the tractor from outside of the drivers seat.

Lower mower to the ground with the tractor rock shaft control lever. With the engine idling, slowly engage the PTO drive. Move the throttle lever until the PTO speed indicated on the mower is obtained.

The mower is set for a PTO speed of 540 rpm.

Shift the transmission to a slow speed gear and start forward, increase the ground speed by shifting upward until the desired speed is obtained.



CAUTION: Do not operate this mower at a PTO speed or direction of rotation other than that shown on the mower. Serious damage can occur to the machine and/or the operator.

Before starting to mow, never forget that the **operator is responsible** for the following:

1. Safe and correct driving of the tractor and mower.
2. To learn precise safe operating procedures for both the tractor and the mower.
3. To ensure all maintenance and lubrication has been performed on the mower.
4. To have read and understood all safety aspects for the mower in the operator's manual.
5. To have read and understood all safety decals on the mower.
6. Checking the condition of the blades. Worn or damaged blades should be changed before starting.
7. Checking that there is no wire, weed, grass or other material wrapped around blades.
8. Checking to see if front weights need to be added to the tractor in order to maintain balance.
9. Checking the tractor tires for the proper pressure in accordance with the tractor operator's manual.
10. **Checking that the PTO shield, belt shields and all other shielding are on the machine and securely in place.**
11. Making sure the proper attire is worn. Avoiding loose fitting clothing which can become entangled. Wearing sturdy, tough-soled work shoes and protective equipment for eyes, hands, ears and head. Never operate tractor or implements in bare feet, sandals or sneakers.
12. Checking area for stones, branches and other debris that might be thrown.
13. Ensuring proper lighting is available, sunlight or good artificial lighting.

3.06 - Working Speed

The mowing speed depends on ground conditions, tractor HP, mowing height, and grass thickness. Only a test run will enable you to gauge the optimal working speed for your conditions. Under most conditions a 5 to 6 mph ground speed is best. For a good quality cut it is recommended to keep a steady work speed no slower than 5 mph. This will facilitate grass discharge. Working speed should never exceed 6.5 mph to avoid damage to the unit.

In order to avoid clogging up of blade or if grass is tangled or flattened it is recommended to keep cutting bar grazing the ground.

In order to obtain the best cut possible, always keep the tractor rpm up to the speed indicated on the mower. When increasing or decreasing mowing ground speed, always use gear selection, not engine speed. This will maintain the constant maximum blade speed necessary for a clean cut.

All of the following factors are important in selecting the proper forward speed:

1. Height of grass.
2. Type of grass.
3. Density of grass.
4. Type of terrain.
5. Grass condition, wet or dry.

3.07 - Operating Techniques



DANGER: If blades become jammed it is advisable to operate carefully wearing adequate personal protection before attempting to free them from obstruction.

Always operate PTO at 540 rpm. This is necessary to maintain proper blade speed, obtain a clean cut and reduce the risk of jamming the blades.

Always raise the implement before reversing or changing direction.

Working Position

Raise the stand, remove safety shield from cutting bar, disengage safety lever (**see fig. 11**), lower cutting bar, fit the sickle bar by adjusting the tractor tie-rods so that when sickle bar attachment is fitted to the three points on the tractor, the external tip of the cutting arm is approximately 2" forward with respect to the arm base.

Use the chain near the lower right hitch pin of the mower to adjust the height of the sickle bar mower with respect to the tractor. To adjust the height attach the appropriate link through the hole on the tractor coupling plate provided with the mower. It is advisable to mark the link of the chain used so that the same position may be used again each time the sickle bar is fitted to the tractor (**see fig. 10**).

Operating the sickle bar

When mowing, the bottom of the three point hitch frame should be approximately 18" off the ground (**see fig. 10**). Never operate the sickle bar with the three point hitch close to the ground as this could cause damage to the frame and/or the hydraulic cylinder.

Adjust the inclination of the cutting bar by using the turnbuckle (**see fig. 10**).

It is possible to adjust the cutting height of the cutting bar from a minimum of 1.2" to a maximum of 2.7" by simply bolting the internal and external skid shoes into one of the other holes provided on the unit.

Sickle Bar Mower BF MJ

Operator's Manual

Sickle bar mowers are equipped with dual action hydraulic cylinders that allow operator to easily raise or lower the cutting bar to achieve the desired cutting angle or mechanical lift. Dual action cylinders require two available remotes on the tractor to be able to work.

If your tractor does not have two remotes, it is possible to convert the hydraulic cylinder into a single action cylinder by removing the cylinder fitting closest to the three point hitch and replacing it with a breather plug.



DANGER: To close the machine with hydraulic cylinder you have to use the cylinder to put in the closure position the blade. With the mechanical lift you have to close manually the blade. **YOU MUST PAY ATTENTION** to close the blade and touch the blade support **ONLY** to the fix part and **NOT** touching the blade bars.

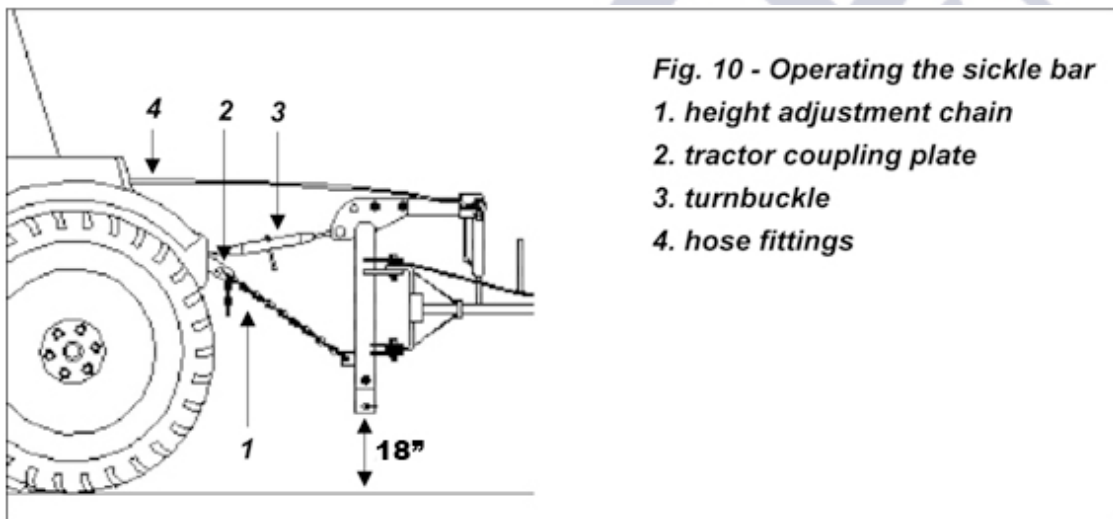

Raising and lowering of cutting bar

Before carrying out any raising and lowering operations, make sure to disconnect PTO shaft from tractor and make sure that all moving parts have come to a complete stop.

Our sickle bar mowers are equipped with a locking safety lever that the operator engages once cutting bar is raised (**see fig. 11**).

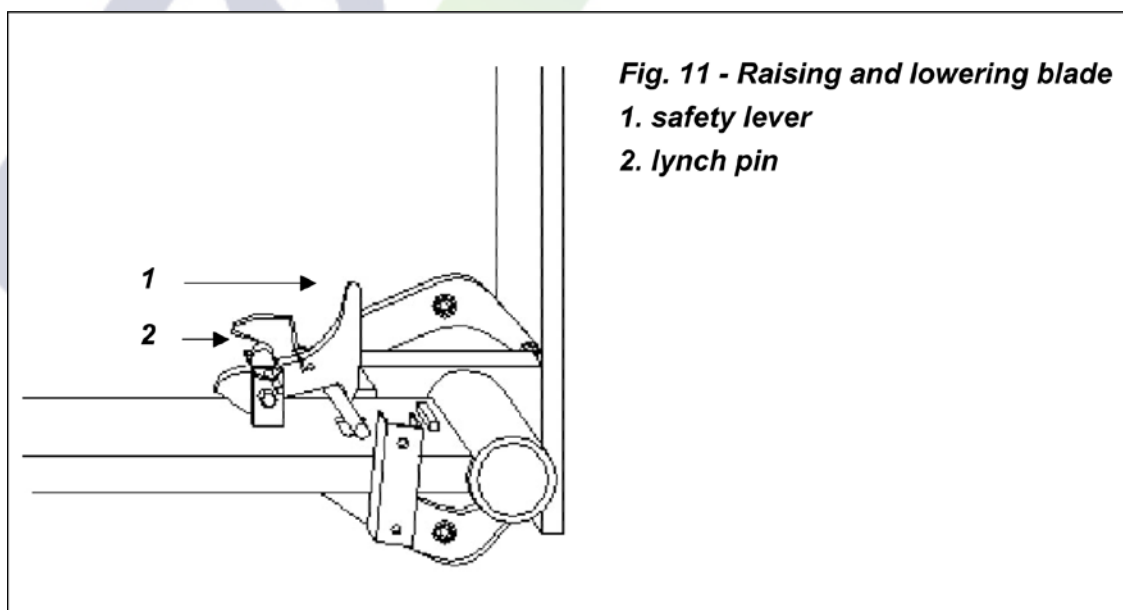

To disengage the lever, the operator must do so manually. Remove lynch pin securing lever, push cutting bar towards main frame to make lever rise, hold lever up and allow cutting bar to disengage.

IMPORTANT: When using the cutting bar raise lock, regularly check that the cylinder stop is resting along the cylinder.

Cutting bar raise lock

Sickle bar mowers are equipped with a cutting bar raise lock (see fig. 12). This lock allows operator to raise the cutting bar approximately 12" from the ground and turn around so that end of field maneuvers can be carried out without ever having to raise the three point hitch. Once the tractor is turned around, operator lowers the cutting bar and resumes mowing.

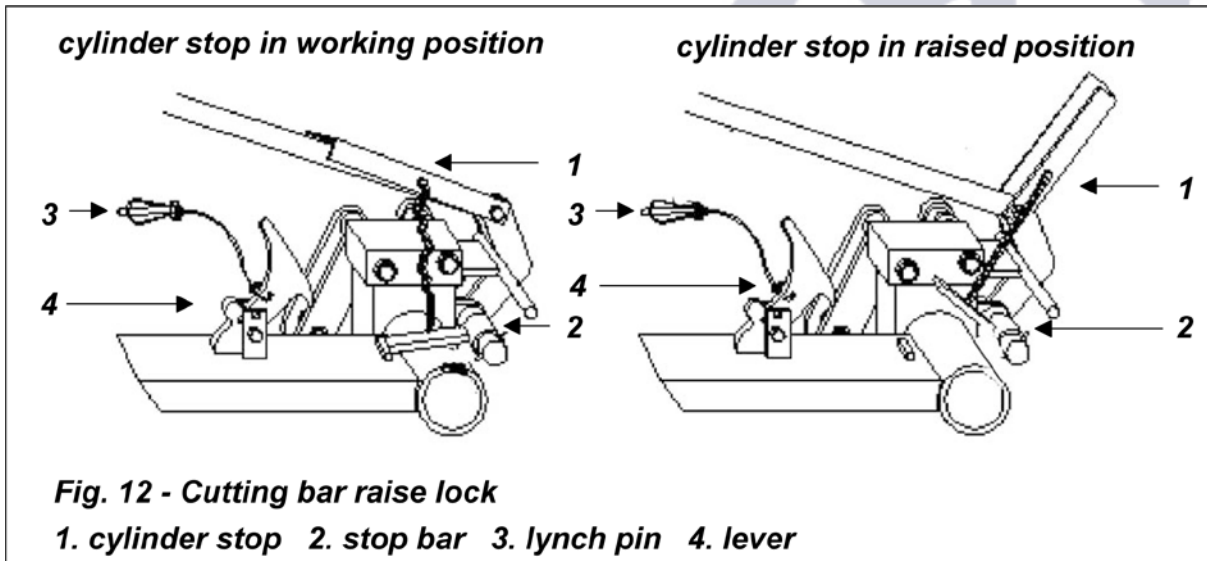

Safety release latch

The sickle bar mower is protected with a safety release mechanism (see #2, fig. 13). If the cutter bar is driven into a foreign object such as a tree or a pole, the safety release mechanism will allow the cutter bar to swing back to avoid major damage to the unit. In the event of a collision with a foreign object, immediately stop the tractor, do not raise sickle bar. Turn off tractor engine and make sure the driveline halves have not become separated, if so, reassemble the two halves. To reset safety release, back up tractor until latch returns to its normal position. If the safety release latch breaks away too often adjust the spring using nut bolted at the end and tighten a half turn at a time (see #3, fig. 13).



DANGER: The mower blades can throw objects hundreds of feet which could result in personal or property damage. Pick up all rocks and other debris before mowing.

Enter new areas carefully. Cut grass higher at first, allowing mower to clear hidden objects.



CAUTION: For emergency reasons learn how to stop the tractor and mower quickly. On the sickle bar mower always disengage the PTO, lock parking brake, stop engine and allow the blades to come to a complete stop before dismounting the tractor.

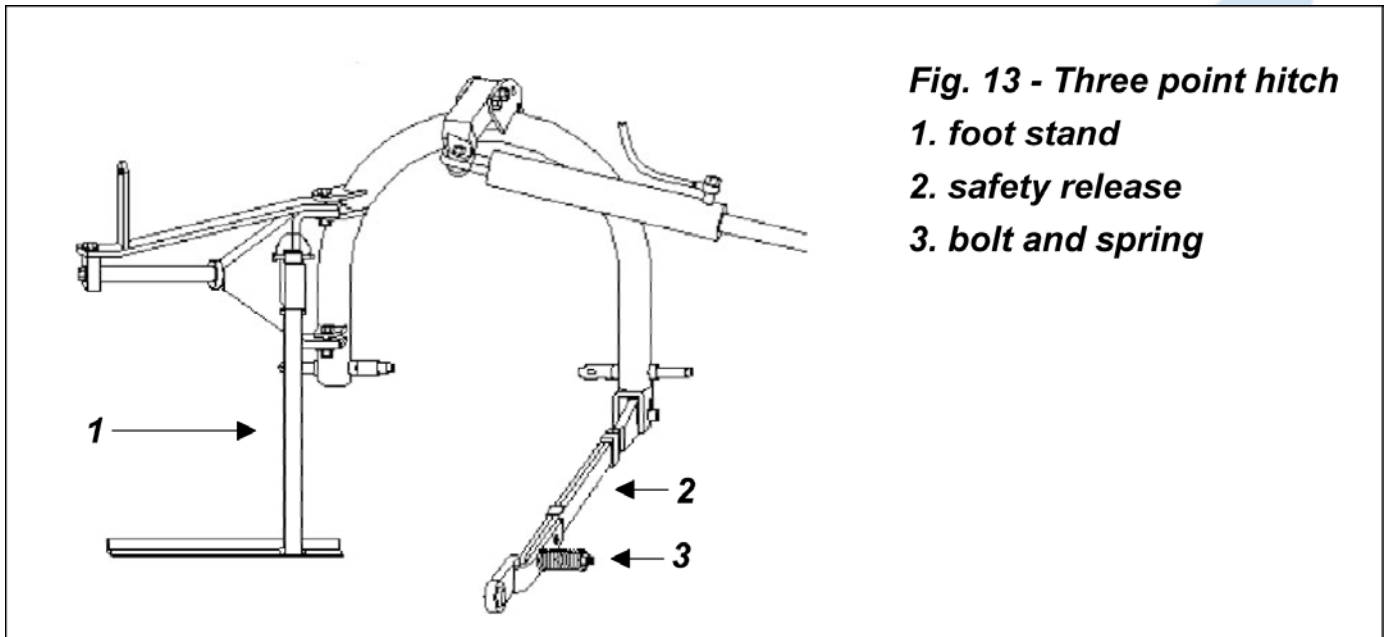

Fig. 13 - Three point hitch

1. foot stand

2. safety release

3. bolt and spring

3.08 - Uneven Terrain



DANGER: Be careful of rollover when operating tractor and implement over uneven ground.

The following precautions should always be observed when working on uneven terrain:

1. In extremely uneven terrain rear wheel weights, front tractor weights, and/or tire ballast should be used to improve stability.
2. Observe the type of terrain and develop a safe working pattern.
3. Whenever traction or stability is doubtful, first test drive over the terrain with the PTO disengaged.
4. Operate the implement up and down steep slopes, not across slopes, to prevent the tractor from tipping. Avoid sudden stops and starts, slow down before changing directions on a slope.
5. Pass diagonally through sharp dips and avoid sharp drops to prevent hanging up the tractor and implement.
6. Slow down on sharp turns and slopes to prevent tipping or loss of control.
7. Watch for holes, roots or other hidden objects. Do not use near the edge of a gully, ditch or stream bank.

NOTE: When mowing over uneven terrain keep cylinder stop lock in raised position (see fig. 12).

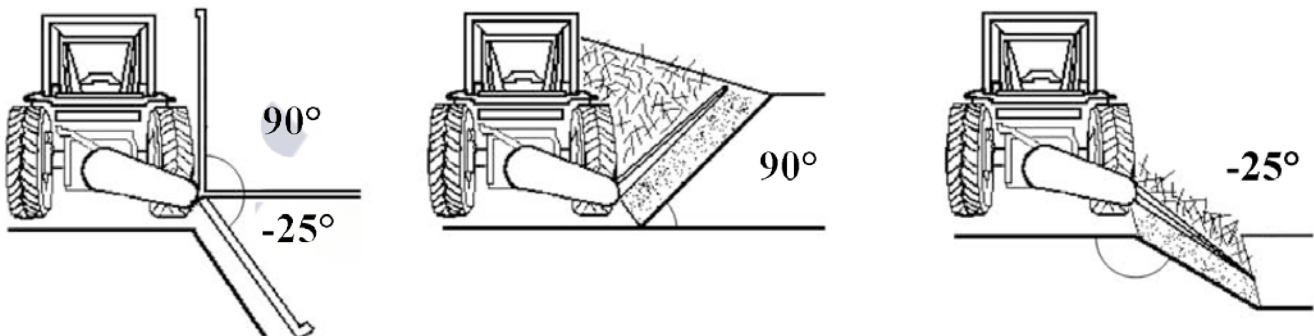

3.10 - Removing Mower from Tractor



DANGER: Avoid injury from blade. Always replace safety shield on cutting bar when mower is not in use.

To remove the mower from the tractor do the following:

1. Set up sickle bar on level and solid ground.
2. Disengage tractor PTO.
3. Set parking brake.
4. Raise the sickle bar.
5. Replace safety shield on cutting bar.
6. Put support stand in position and secure with pin.
7. Lower sickle bar to the ground.
8. Stop engine and remove key from ignition.
9. Disconnect mower driveline from tractor PTO shaft.
10. Disconnect three point linkage and carefully drive tractor away from mower.



CAUTION: Disengage tractor PTO. Set parking brake. Stop engine and remove key from ignition. Disconnect mower driveline from tractor PTO shaft. Collapse driveline and secure it in a safe place. Disconnect three point linkage and carefully drive tractor away from mower.

4.04 - Transport

Before transporting:

Adjust and fix the tie-rods of the side lifting arms of the tractor. Lift the cutting bar and engage the safety lever. Replace the safety shield on the cutting bar. Lift implement and place the hydraulic lifting command lever in locked position. Always select a safe ground speed that is appropriate for the terrain. Beware of traffic on public roads. Install a SMV (Slow Moving Vehicle) sign when traveling on roads or streets. Reduce ground speed when turning and take care that the mower does not strike obstacles such as trees, fences or buildings.



CAUTION: Make sure PTO is disengaged and blades have come to a complete stop before raising mower to full transport position.

Do not tow tractor and mower behind other vehicles. Use a properly equipped trailer with heavy tie-downs for towing operations.

4 – MAINTENANCE



DANGER: Stop engine, lock parking brake and remove key before performing any service or maintenance.

Never rely on the tractor lift system. Install blocks or stands under the implement to prevent it from falling.

Always use personal protection devices, such as glasses or gloves when performing maintenance.

Keep fingers out of slots to prevent injury.

4.01 - Maintenance Safety



1. Good maintenance is your responsibility.
2. Keep service area clean and dry. Be sure electrical outlets and tools are properly grounded. Use adequate light for the job at hand.
3. Make sure there is plenty of ventilation. Never operate the engine of the towing vehicle in a closed building. The exhaust fumes may cause asphyxiation.
4. Make no repair or adjustments with the tractor engine running. Before working on the machine, disengage the PTO, shut off the engine, set the brakes, and remove the ignition key.
5. Be certain all moving parts on attachment have come to a complete stop before attempting to perform maintenance.
6. Never work under equipment unless it is blocked securely.
7. Always use personal protection devices such as eye, hand and hearing protectors, when performing any service or maintenance.
8. Frequently check mower blades. They should be sharp, free of nicks and cracks and securely fastened.
9. Periodically tighten all bolts, nuts and screws and check that all cotter pins are properly installed to ensure unit is in a safe condition.
10. When completing a maintenance or service function, make sure all safety shields and devices are installed before placing unit in service.
11. Do not attempt to mount a tire unless you have the proper equipment and experience to do the job.
12. Inflating or servicing tires can be dangerous. Whenever possible, trained personnel should be called to service and/or mount tires.
13. After servicing, be sure all tools, parts and service equipment are removed.
14. Never replace hex bolts with less than grade five bolts unless otherwise specified, i.e. shear bolts (Refer to Table 1 - Torque Specifications).
15. Where replacement parts are necessary for periodic maintenance and servicing, genuine replacement parts must be used to restore your equipment to original specifications. The company will not claim responsibility for use of unapproved parts and/or accessories and other damages as a result of their use.
16. Unauthorized modifications to the machine may impair the function and/or safety of the machine and reduce its life. If equipment has been altered in any way from original design, the manufacturer does not accept any liability for injury or warranty.

4.02 - Service

The chart below gives the frequency of lubrication in hours, based on normal operating conditions. Severe or unusual conditions may require more frequent lubrication.

Use a good quality SAE multipurpose type grease for all locations shown. Be sure to clean fittings thoroughly before using grease gun.

Fig. 15 - Belt tightening

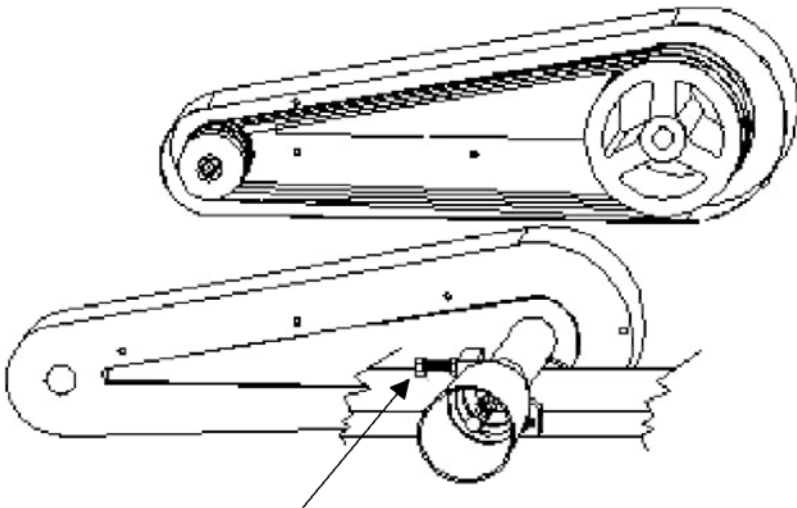

Belt tension is adjusted through the bolt. Tighten bolt to increase tension, release bolt to decrease tension. Belt slack must not exceed 1".

After each mowing job:

Clean and oil the cutting blades.

Every 8 hours:

Grease all points. Grease PTO shaft and all telescoping parts. Adjust belt tension (**see fig. 15**). Belt slack must not exceed one inch.

Every 25 hours:

Hardware tightness: vibration can loosen bolts. Check tightness of the hardware Periodically (See Table 1).

Every 50 hours:

Check the clearance between the cutting blades and the upper blade guide.

4.03 - Driveline



DANGER: Only use the original driveline supplied with this mower and always with the safety shielding. Carefully read and file away the driveline operator's manual supplied by the manufacturer. The following does not substitute the information found in the driveline manual.

IMPORTANT: Always check driveline length during initial setup and when connecting to a different tractor.

In the collapsed position the driveline should be approximately 2" from bottoming out to prevent possible damage to the tractor or implement. When the driveline is in the maximum extended position, the ideal minimum overlap of the two halves should be approximately 6" (see fig. 16).

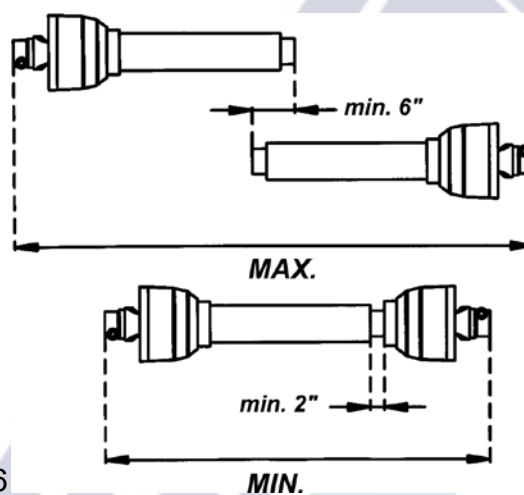

Fig.16







If determined that the driveline is too long, follow these procedures to adjust the length:

1. Separate the two driveline halves. Connect one half to the tractor PTO and the other half to the mower.
 2. Raise and lower the mower with the 3 point hitch to find the position where the driveline is shortest. Hold the half shafts side by side and mark the desired length on the outer female tube guard leaving a 1½" gap between the end of the guard tube and bell guard.
 3. Cut off both guard tubes the same amount as marked in step 2.
 4. Shorten both drive tubes the same amount as guard tubes.
 5. De-burr and clean filings from drive tubes and apply grease to outside of inner telescoping tube.
 6. Reassemble the driveline halves and connect to tractor and mower. Raise and lower mower again to be sure driveline does not bottom out in its shortest position and has a minimum overlap of 6" in the longest position.
 7. Install both driveline safety chains. One should be hooked in a hole on the outer driveline yoke shield and to the tractor to restrict outer shield rotation. The second one should be hooked in a hole on the inner driveline yoke shield and to the implement to restrict inner shield rotation.
- If determined that the driveline is too short for your tractor, contact your local dealer.



CAUTION: Always work with the driveline as straight as possible. This will prolong its life and that of its components. It is advised not to work at an angle greater than 15 degrees.

TABLE 1 - TORQUE SPECIFICATIONS

Metric (ISO) treaded bolts head marking		 Class 5.8	 Class 8.8	 Class 10.9	Inch (SAE) treaded bolts head marking		 Grade 2	 Grade 5	 Grade 8						
Bolt size mm	Thread mm	N.m	ft-lb	N.m	ft-lb	N.m	ft-lb	Bolt size inch	Thread inch tpi	N.m	ft-lb	N.m	ft-lb	N.m	ft-lb
M5	0.8	4	3	6	4	9	7	1/4"	20	7	5	11	8	16	12
M6	1	6	4	10	7	15	11	1/4"	28	8	6	13	10	19	14
M8	1.25	16	12	25	18	36	27	5/16"	18	15	11	24	17	33	25
M8	1	17	13	26	19	38	28	5/16"	24	17	13	26	19	37	27
M10	1.5	31	23	48	35	71	52	3/8"	16	27	20	42	31	59	44
M10	1.25	33	24	51	38	75	55	3/8"	24	31	23	47	35	67	49
M10	1	35	26	53	39	78	58	7/16"	14	43	32	67	49	95	70
M12	1.75	54	40	84	62	123	91	7/16"	20	48	36	75	55	106	78
M12	1.5	56	41	87	64	128	94	1/2"	13	66	48	102	75	144	106
M12	1.25	59	44	90	66	133	98	1/2"	20	75	55	115	85	163	120
M14	2	84	62	133	98	195	144	9/16"	12	95	70	147	109	208	154
M14	1.5	94	69	142	105	209	154	9/16"	18	106	79	164	121	232	171
M16	2	131	97	206	152	302	223	5/8"	11	132	97	203	150	287	212
M16	1.5	141	104	218	161	320	236	5/8"	18	149	110	230	170	325	240
M18	2.5	181	133	295	218	421	310	3/4"	10	233	172	361	266	509	376
M18	2	196	145	311	229	443	327	3/4"	16	261	192	403	297	569	420
M18	1.5	203	150	327	241	465	343	7/8"	9	226	167	582	430	822	606
M20	2.5	256	189	415	306	592	437	7/8"	14	249	184	642	473	906	668
M20	1.5	288	212	454	335	646	476	1"	8	339	250	873	644	1232	909
M22	2.5	344	254	567	418	807	595	1"	12	371	273	955	704	1348	995
M22	1.5	381	281	613	452	873	644	1-1/8"	7	480	354	1077	794	1746	1288
M24	3	444	327	714	526	1017	750	1-1/8"	12	539	397	1208	891	1958	1445
M24	2	488	360	769	567	1095	808	1-1/4"	7	677	500	1519	1120	2463	1817
M27	3	656	484	1050	774	1496	1103	1-1/4"	12	750	553	1682	1241	2728	2012
M27	2	719	530	1119	825	1594	1176	1-3/8"	6	888	655	1992	1469	3230	2382
M30	3.5	906	668	1420	1047	2033	1499	1-3/8"	12	1011	746	2268	1673	3677	2712
M30	2	1000	738	1600	1180	2250	1659	1-1/2"	6	1179	869	2643	1949	4286	3161
M36	4	1534	1131	2482	1830	3535	2607	1-1/2"	12	1326	978	2974	2194	4823	3557

When using lock washers with nuts, increase torque values by 5%.

TABLE 2 – SICKLE BAR MOWERS – TECHNICAL FEATURES

Sickle bar mower BF MJ							
Model	HP	Working width	Weight Kg.	Lift	Max. working speed	PTO (rpm)	Driveline 1 3/8"
BF 105 MJ	16-40	105 cm	190	Hydraulic / Mechanic	6,5 mph	540	ASAE cat. 2
BF 120 MJ	16-40	120 cm	200	Hydraulic / Mechanic	6,5 mph	540	ASAE cat. 2
BF 135 MJ	16-40	135 cm	210	Hydraulic / Mechanic	6,5 mph	540	ASAE cat. 2
BF 150 MJ	16-40	150 cm	220	Hydraulic / Mechanic	6,5 mph	540	ASAE cat. 2

5 - REPAIR PROCEDURES



CAUTION: All repair procedures must be done by authorized dealerships. It is not recommended that untrained individuals perform any repair work.

5.01 - Blade Replacement

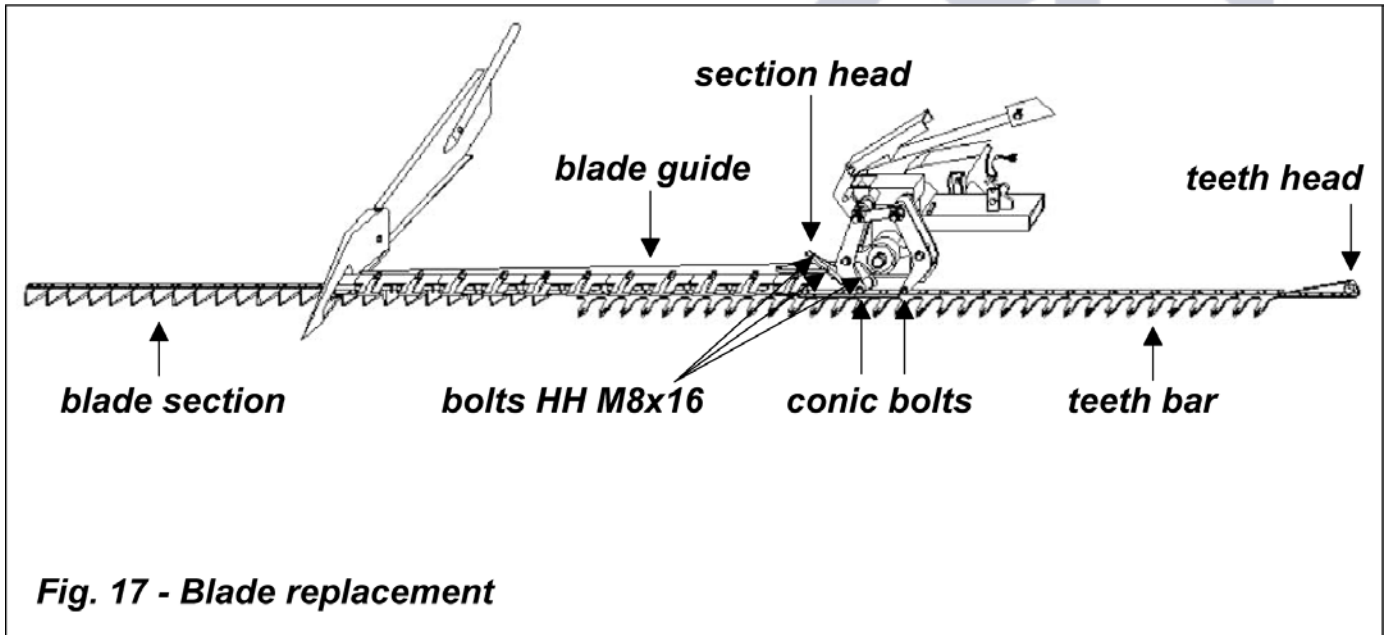

Checking blade clearance

Every 50 hours or whenever the blade section or teeth bar is replaced the clearance between the teeth bar and blade guide must be checked. Always try to keep approximately 1 mm. clearance between the teeth bar and the blade guide (**see fig. 18**).

Too much clearance can cause material to become entangled with the cutting blade leading to possible failure of parts or poor cutting quality. Too little clearance will cause excessive friction on the blades causing possible failures to the cutting bar.

Adjusting the clearance between the blade guide and the teeth bar is done by simply tightening or loosening the set screws that are located on the blade guide (**see fig. 18**).

After adjusting the clearance check the hex head nut (M10) in front of each set screw to make sure it is adequately tightened.

Replacement of blade section

With the implement resting on the ground lower the cutting bar so that it is laying flat on the ground. Remove the three hex head bolts (M8x16) and nuts (M8) from the section head and pull out the blade section from the outside of the cutting bar by inserting a metal hook through the hole on the furthestmost blade (**see fig. 17**). Reassemble the new blade section and assemble it to the section head using the three bolts (M8x16) and nuts. If necessary, lubricate the blade section to facilitate removal and replacement work.

Move blade section and teeth bar back and forth to make sure both slide well in the blade guide. It is important for the blade section and teeth bar to slide easily and with no obstructions inside the blade guide.

Replacement of individual blade

With the implement resting on the ground lower the cutting bar so that it is laying flat on the ground. Remove the three hex head bolts (M8x16) and nuts (M8) from the section head and pull out the blade section from the outside of the cutting bar by inserting a metal hook through the hole on the furthestmost blade (**see fig. 17**). Remove the rivets of the damaged blade using a pin punch. Rivet on a new blade making sure rivets are assembled flush with the rod section. Once the new blade is riveted on the rod section reassemble the blade section and assemble it to the section head using the three hex head bolts (M8x16) and nuts (M8). If necessary, lubricate the blade section to facilitate removal and replacement work.

Replacement of teeth bar

With the implement resting on the ground lower the cutting bar so that it is laying flat on the ground. Remove the conic bolt (**see fig. 17**) and pull out the teeth bar by inserting a metal hook through the teeth head. Insert the new blade section and lock in place with the conic bolt. Torque conic bolts to 95 ft-lb. If necessary, lubricate the teeth bar to help removal and replacement work.

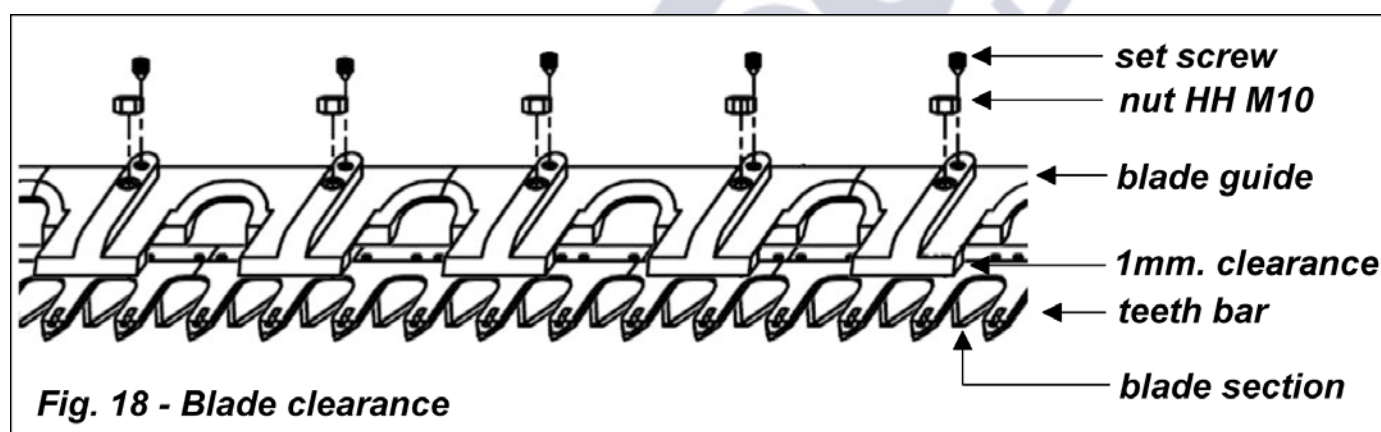

DANGER: Avoid injury from blade. Always replace safety shield on cutting bar when mower is not in use.

5.02 - Suggested Spare Parts

It is suggested that the following spare parts be kept on hand for the implement at all times to prevent a minor problem from delaying work.

Description	Quantity
Complete blade section	1
Conic bolt	2

5.03 – Storage

After seasonal use it is important to perform the following for prolonged storage:

1. Wash the implement carefully.
2. Inspect the implement and replace worn or damaged parts.
3. Replace safety shield on cutting bar.
4. Tighten all hardware.
5. Grease all areas indicated under Maintenance (See Chapter 4 – Maintenance).
6. When placing machine in storage, lower the support stand and secure it with the lock pin before lowering the unit to the ground.
7. Cover the implement from the elements in order to have it in perfect condition for the start of the next season.



WARNING: Be sure to store the implement on a hard level surface, with the safety shield installed on the cutting bar, away from people especially children.

6 – TROUBLESHOOTING



WARNING: Be sure tractor engine is off, parking brake is locked, and key is removed before making any adjustments.

PROBLEM	POSSIBLE CAUSE	SOLUTION
Tractor only has one remote while the sickle bar requires two remotes to hookup to the tractor.	Unit comes standard with a dual action hydraulic cylinder.	Dual action cylinder may be converted into a single action cylinder by removing the fitting closest to the three point hitch and fitting it with a breather plug.
Material becomes entangled on the bar.	Too much clearance between cutting blade teeth and upper blade guide.	Check to make sure there is no more than 1 mm. clearance between blade teeth and upper blade guide.
Teeth bar or blade section often fails.	Too little clearance between blade teeth and upper blade guide can create excessive sliding friction on the blade that may result in failures.	Check to make sure there is at least 1 mm. clearance between blade teeth and upper blade guide.
Conic bolts on cutting bar come loose.	Bolts not properly torqued.	Torque conic bolts to 95 ft-lb.
Conic bolts on cutting bar shear.	Bolts not properly torqued. Loose belts cause blade teeth to jam and conic bolt to fail.	Torque conic bolts to 95 ft-lb. Tighten belts so there is less than 1" slack.

7 - PRE-DELIVERY CHECKLIST

To the dealer: Inspect the machine thoroughly after assembly to assure it is functioning properly before delivering it to the customer. The following checklist is a reminder of points to cover. Check off each item as it is found satisfactory or after proper adjustment is made.

- Guards and shield properly fastened.
- Lubrication of grease fittings.
- All hardware properly tightened.
- Belts are properly tightened.
- All decals properly located and readable (**see fig. 7**).
- Blade section and teeth bar properly installed.
- Overall condition (touch up scratches, clean and polish).
- Test run, check for excessive vibration or overheating of bearings.
- Operator's Manual.

Review the Operator's Manual with the customer. Explain the following:

- Warranty.
- Safe operation and service.
- Correct machine installation and operation.
- Daily and periodic lubrication, maintenance and inspections.
- Troubleshooting.
- Operational procedures and storage.
- Parts and service.
- Fill out the Pre-Delivery Checklist and Warranty Registration form.
- Give customer the Operator's Manual and encourage the customer to read the manual carefully.

IMPORTANT: Warranty is not valid unless Pre-Delivery Checklist and Warranty Registration Form in operator's manual is completed in detail and mailed to the Company.

Model Number: _____ Serial Number: _____

Delivery Date: _____ Dealer's Signature: _____

8 – WARRANTY

DCM Italia's responsibility will be limited to substitution of the acknowledged defective merchandise to our Italian head office..

1. LIMITED WARRANTY

DCM Italia here in referred to as the Company, warrants its machines and related accessories, hereafter referred to as the Machine, to be free from defects in material and workmanship, for a period of twelve (12) months from the date of our invoice. this limited warranty does not apply to common wear items and excludes belts, shear pins, oil, grease, tires, tubes, hydraulic hoses, knives and PTO shafts.

Cost of transport to the servicing dealer is the responsibility of the customer.

Warranty coverage shall not be transferable from the first owner to any subsequent owner.

2. DISCLAIMER OF ALL OTHER WARRANTIES AND REMEDIES

Neither the Company nor any company affiliated with the Company makes any warranties, representations or promises, expressed or implied, as to the quality, performance or application of its products other than those set forth herein and does not make any implied warranty of merchantability or fitness. The only remedies the purchaser has in connection with the breach, or performance of any warranty on the Company's Machine are those set forth herein. In no event will the dealer, the Company, or any company affiliated with the Company, be liable for:

- a. Injuries or damages of any kind or nature, direct, consequential or contingent to person or property.
- b. Any expenses incurred by the owner to repair, replace or rework any allegedly defective item.
- c. Any loss, cost, forfeiture or damages (including loss of profits; loss of crops; loss because of delay in field operations; any expenses or loss incurred for labor, supplies, substitute machine rental; liabilities of the owner to its customers or third persons; and all other consequential damages, losses, liabilities or damages for any other reasons) whether direct or indirect, and whether or not resulting from or contributed to by the default or negligence of the Company, its agents, employees and subcontractors which might be claimed as a result of the use or failure of the equipment delivered.

The Company's liability based on this limited warranty or any other applicable laws shall be limited to replacement or refund of the purchase price of the product.

The limited warranty extended herein gives you specific rights and you may also have other rights which vary from state to state. Neither the dealer nor the Company personnel has the authority to make any representation or to modify the terms and limitations of this warranty in any way.

Other than the limited warranty extended hereby there is no other expressed warranty in connection with the design, safety or use of any of the Company's products except as to title. All implied warranties are expressly disclaimed pursuant to the terms of this warranty.

3. CUSTOM WORK

If the Machine is used for commercial purposes such as custom work, the period warranted for the Machine is limited to six (6) months from the date of delivery to our invoice date and does not cover any labor charges incurred.

4. RENTAL

If the Machine is used for rental purposes the period warranted for the Machine is limited to thirty (30) days from the date of delivery to the first registered owner and does not cover any labor charges incurred.

5. REGISTRATION

In order to qualify for coverage on this limited warranty, the product and name of the original purchaser must be registered with the Company by a completed Machine Pre-Delivery Checklist and Warranty Registration along with a copy of the dealer's invoice to the first registered owner to the Company within fourteen (14) days after the date of delivery to the original purchaser.

6. WARRANTY SERVICE

Warranty Service must be performed by a dealer authorized by DCM Italia. If the warranty service requested is approved, the owner shall pay for labor beyond the rate allowed, for overtime labor, and for any mileage charge for transporting the equipment to and from the dealer's shop. It is assumed that the dealer has the appropriate general and special tools to service the machine. Time required for replacement of knives, oil, grease and to remove excessive dirt from the Machine is not subject to reimbursement by the Company. The owner is required to clean the Machine before presenting it to the dealer for service work. The Machine must be delivered within thirty (30) days after failure date by the owner to the dealer to be eligible for warranty consideration. DCM Italia cover in warranty only the spare parts only if the warranty is confirmed from us.

7. UNAPPROVED SERVICE OR MODIFICATION

All obligations of the Company under this limited warranty shall be terminated if:

- a. Proper service and operation instructions as outlined in the Operator's Manual and on the instruction sticker on the Machine, are not followed.
- b. The Machine is modified or altered in any way not approved by the Company.
- c. The Company does not receive a copy of the dealers invoice to the first registered owner within fourteen (14) days from the date of delivery.
- d. The Company has not been paid in full, by the dealer, for the Machine.

8. ACCIDENTS AND NORMAL MAINTENANCE

This limited warranty covers defective material and workmanship. It does not cover depreciation or damage caused by normal wear, accidents, improper maintenance, improper protection or improper use. The costs of normal maintenance or repairs for accidents or improper use, and related labor will be borne by the owner.

9. REPLACEMENT PARTS

DCM Italia warrants replacement parts to be free from defect in material and workmanship for a period of thirty (30) days from the date of delivery to the original purchaser.

All the guarantees MUST BE CONFIRMED BY DCM ITALIA TO BE CONSIDERED VALID.

WARRANTY REGISTRATION

DCM Italia s.r.l.
Via Caduti del Lavoro, 34
43043 Borgo Val di Taro PR – Italy
Tel. (+39) 0525 97598 – Fax (+39) 0525 921540

Dealer	Acct. #	Retail Customer
Street	Country	Street
Town	State Zip	Town State Zip
Date of delivery	Invoice #	Phone
Model #	Serial #	
<p>Pre-Delivery Checklist:</p> <ul style="list-style-type: none"> ○ Greased fittings. ○ Safety guards in place. ○ All hardware tight. ○ Bolts torqued correctly. ○ Attached unit to tractor. Yes/No. ○ Field adjusted. Yes/No. ○ Test run. Dry/Infield. ○ Safety decals. ○ Operator's Manual. <p>The machine described above has been prepared for delivery according to the Pre-Delivery Checklist and the Customer has been instructed in its care and operation and the condition of warranty.</p>		<p>Tractor make: Model: _____ ; HP _____ Type of operation: Private homeowner, Landscaping, Commercial maintenance, Golf Course, Municipality, Turf Farm, others: Approximate number of acres machine will be used on annually: I hereby acknowledge that: I have received and accepted delivery of the machine described. The equipment was checked thoroughly for loose or missing parts and has been adjusted in accordance with the Pre-Delivery Checklist. I have read and understand the nature and extent of the warranty and understand clearly that there were and are no other representations of warranties either expressed or implied, made by anyone. I have been advised on proper operation, maintenance and lubrication procedure of this equipment. I have been instructed on and do understand the application, limitation and capacities this equipment was designed and recommended for, all as described in the Operator's Manual and literature published by the Company.</p>
Inspected by: _____		
Date: _____		Date: _____
Dealer's Signature: _____		Customer's Signature: _____

This registration along with a copy of the invoice must be sent to DCM Italia s.r.l. within 14 days of date of purchase.

Sender:

Fold here

**Place stamp
here**

Cut along this line

