

## USE AND MAINTENANCE MANUAL

# SLASHER TYPE CENTURION SUPER

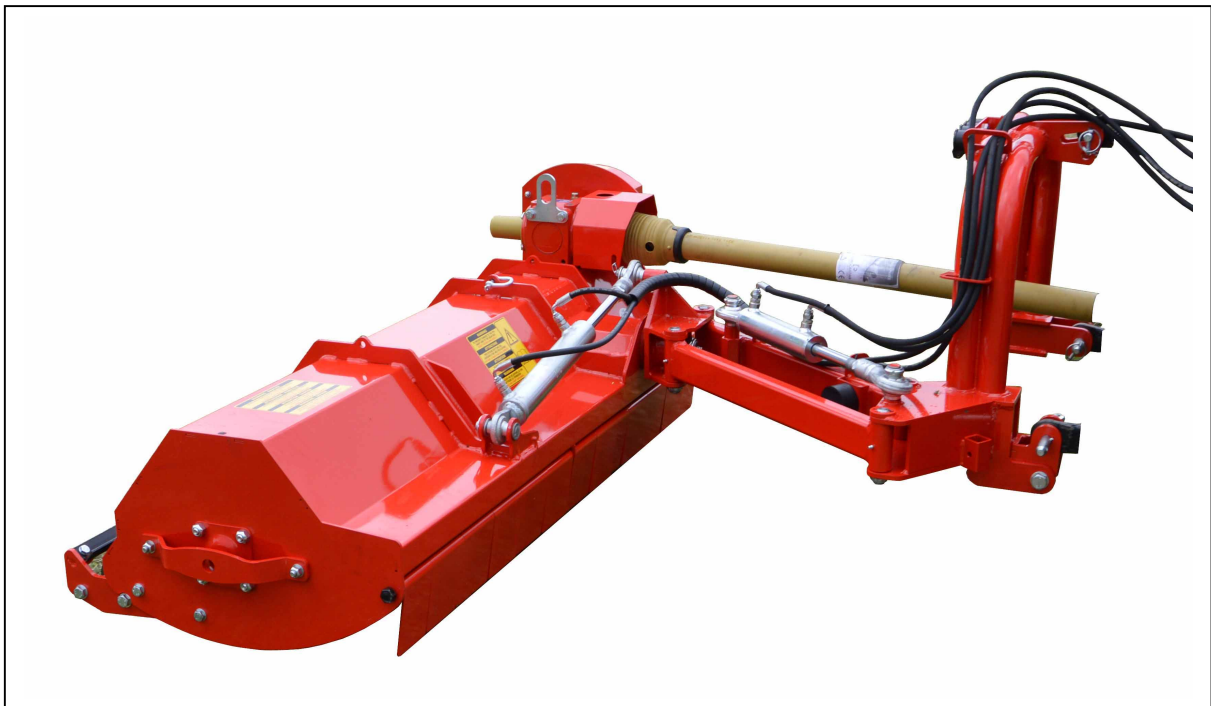

## PREFACE

### **This manual is an integral part of the machine.**

It must always accompany the machine and be kept within reach of the operator.  
The enclosures mentioned are an integral part of this manual.

### **The purpose of this manual.**

This manual gives information for the correct and safe use of the machine.  
The owner must read this manual carefully before work with the machine.

### **Responsibility of the owner**

The owner is responsible for accidents or damages caused to people or things due to negligence in following the instructions in this manual.

### **Assistance in using this manual**

Explanations: contact the dealer.

Request for additional copies of the manual: in case of loss or wear and tear, or in case one wants the manual in a different language, the customer should ask the dealer or manufacturer.

### **Pay attention to the warning signals**



**<Danger>**: indicates a situation that is potentially dangerous which, if not avoided, will cause death or serious damage.



**<Warning>**: indicates a situation that is potentially dangerous which, if not avoided, will cause death or serious damage.



**<Caution>**: indicates a situation that is potentially dangerous which, if not avoided, can cause minor to moderate damage, or it indicates to be careful about an unsafe procedure.

**<Important>** : indicates instructions that must be followed precisely in order to avoid damage to the product, process or environment.

**<Note>**: indicates supplementary information.

<b>DESCRIPTION</b>
--------------------

### **FUNCTION OF USE**

The machine thanks to the hydraulic adjustment system can makes different functions like cut grass, cut up poles exc.

The use of a technical constructive concept trended to the search of high performances, reduction of trebles and durability, improves the power/consumption ratio of the tractor thanks to the elasticity of the machine frame, to the tools shape, to the perfect rotor balancing and to many original technical solutions.

### **PERFORMANCES**

The machine is connected to the tractor with a three points hitch that gives the motion of translation and with a PTO shaft connected with the tractor PTO that gives the motion of rotation to the hoes shaft.

The hydraulic driven parallelogram mechanism allow to move the machine on the right respect to the center of the tractor, the hydraulic driven rotation mechanism allow to tilt the machine respect to the ground.

The working width is fix and it's determined from the choice of the machine type.

The working depth is adjustable.

The rear roll adjusts the cutting height and provides to tread the cut material.

### **PERFORMANCES LIMIT**

- ❑ Speeds greater than the maximum can compromise the condition of the machine, the quality of the work and the safety of the operator.
- ❑ Maximum power applicable to the gear box: 22 Kw  $\pm$  5% with 540 r.p.m. Superior power to which is indicated can damage irreparably the transmission gear box; especially during heavy works.

---

### **STANDARD EQUIPMENTS**

- **Standard PTO shaft.**
- **Free wheel device inside gear box.**
- **Adjustable rear roll.**

### **VARIANT & OPTIONS**

- **Blade tools.**
- **Hammer tools.**

## TECHNICAL SPECIFICATIONS

### CHARACTERISTICS PER MODEL

Model	Type	Version	Power		Working width		Weight		N° tools	Rotor R.P.M
			Hp	Kw	cm	Inch	kg	lbs.		
<b>CENTURION SUPER</b>	106	C	15-40	11-30	106	42	266	587	32	2410
	132	C	15-40	11-30	132	52	307	677	40	2410
	158	C	15-40	11-30	158	62	320	706	48	2410
<b>CENTURION SUPER</b>	106	M	15-40	11-30	106	42	266	587	16	2410
	132	M	15-40	11-30	132	52	307	677	20	2410
	158	M	15-40	11-30	158	62	320	706	24	2410

**Version:**

**C = Blade**  
**M = Hammer**

	<b>106</b>	<b>132</b>	<b>158</b>
<b>A</b>	65 cm	65 cm	65 cm
<b>B</b>	61 cm	87 cm	107 cm
<b>C</b>	120 cm	146 cm	172 cm
<b>D</b>	130 cm	130 cm	140 cm
<b>E</b>	153 cm	177 cm	201 cm
<b>G</b>	110 cm	120 cm	130 cm
<b>H</b>	90 cm	110 cm	150 cm
<b>L</b>	100 cm	100 cm	100 cm
<b>α</b>	45°	45°	45°

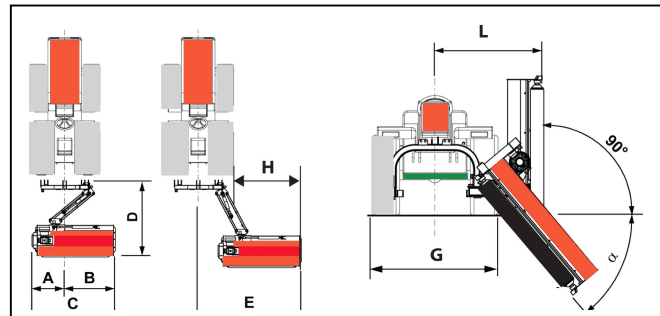



## SAFETY INFORMATIONS

### PRESCRIZIONI GENERALI

- ❑ Only work in daylight.
- ❑ To prevent damage due to lunch of objects or parts of blades, before to start job be sure that any persons or animals should be in the radius of 50 meters from the machine.
- ❑ Wear long pants and heavy shoes.
- ❑ The protections are integral part of the machine: always work with the protections.
- ❑ Pay attention to the soil: make sure that are not stones, sticks, iron wires, etc...
- ❑ Pay attention using the machine on slopes: proceed to the maximum slope and never work in slanting direction.
- ❑ Before leaving the driver's seat, turn off the engine and disengage the transmission engine-shaft.
- ❑ Check immediately the machine if it touches foreign objects.
- ❑ Check immediately the machine if there are unusual strong vibrations.
- ❑ Change quickly defective parts.

### ❑ **CAUTION – WARNING :**

**Gear box has inside a free wheel device, after P.T.O. disconnection rotor turns for at least 30 seconds, before approach the tools be sure that the rotor is stopped.**

### ❑ **WARNING :**

**To prevent damage to the PTO shaft and to the gear box, don't start the machine roughly.**

### SAFETY RESTRICTIONS

Children and people who are not familiar with these instructions must not be permitted to use the machine. Local regulations can restrict the use of the machine in accordance to the age.

### RUNNING IN

A new machine needs a running in. At the first use connect the machine to the tractor, connect the PTO shaft, pull down the machine at 15 centimeter from ground then start the P.T.O. and gradually bring it to 540 r.p.m... Run the machine for about 15 minutes. A whistle in the supports zone it is normal and it's due to the arrangement of the support protection, it will disappear in a few times.

## SAFETY SIGNS ON THE MACHINE

In this section, the safety signs on the machine are reproduced and explained.

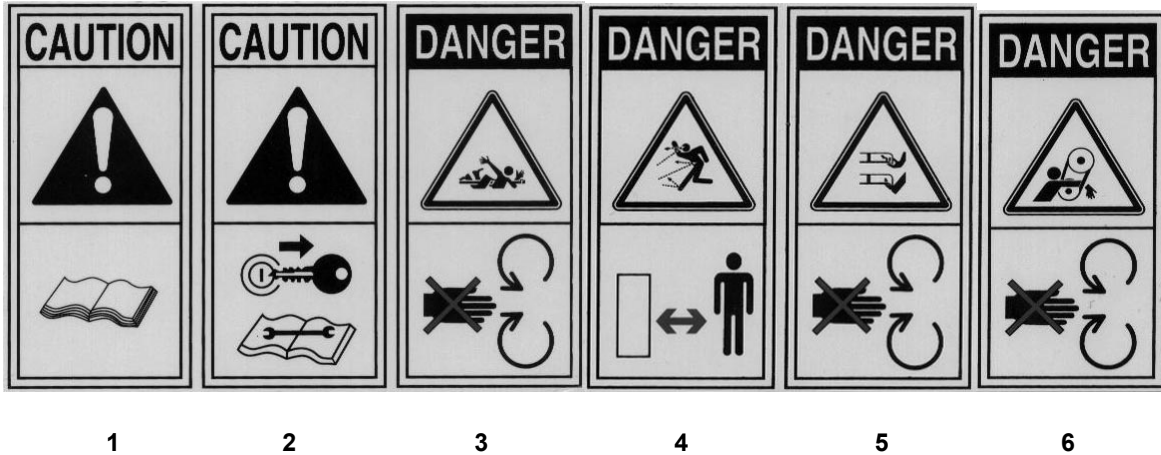

1. Read the operator manual.
2. Disconnect the tractor key before maintenance and repair operations.
3. Stay at safety distance from blades when machine is moving.
1. Danger of flying objects. Stay at safety distance.
4. Stay at safety distance from blades when machine is moving.
5. Stay at safety distance from blades when machine is moving.

**The safety signs on the machine must always be legible.**

In case of damage, the labels of the signs must be substituted.

In the case of the substitution of machine parts that have safety signs, the signs must be replaced.

**Supplying of new safety labels and the application procedure**

Contact your dealer to receive new safety labels with instructions for application.

## INSTRUCTIONS FOR USE

### 1. BEFORE BEGINNING WORK

**ATTENTION** : the machine must be used with a tractor equipped with 4 hydraulic couplings.

a) Hook the machine to the tractor, operate as follows :

1. Remove the safety pins from the two lower connection points of the machine.
2. Plug in the raising tractor beams into the lower connection points of the machine and lock with the safety pins.
3. Connect through tie-rod the third hitch point of the tractor with the third point of the machine (the connection triangle vertex), insert the pin and lock with safety pin.
4. Connect the 4 hydraulic pipes to the tractor hydraulic couplings.

b) With the machine raised, go to work area.

c) Connect the tractor PTO with machine PTO.

d) Check that PTO chain is locked to prevent the protection sheet of PTO rotating.

e) Adjust the cutting height as follow :

1. Unlock the screw "A".
2. Unscrew the screw "B" then take out it.
3. Repeat the same operations on the other side of the machine.
4. Set the position of the roll "C". Moving up the roll cutting height decrease, moving it down cutting height increase.
5. Insert then lock the screws "B", lock the screws "A".

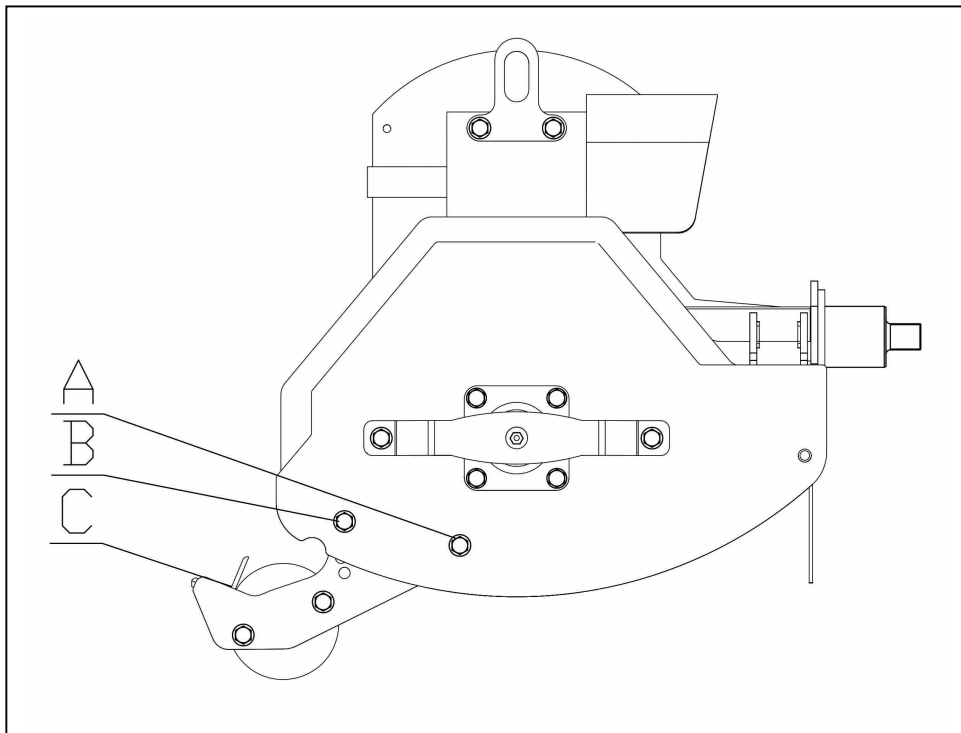

## **2. TO BEGINNING WORK**

- a) Keep people and animals at least 65 feet radius all around the machine.
- b) Pull down the machine until the hoes touch the ground.
- c) Connect PTO power and gradually bring it to 540 r.p.m...
- d) Pull down completely the machine and start to work.

## **3. AT THE END OF CUTTING OPERATION**

- a) Stop the tractor and wait at least 30 seconds that the rotor is completely stopped.
- b) Raise the machine until the hoes goes out from ground.
- c) Disconnect PTO power.
- d) Disconnect tractor PTO from machine PTO.
- e) Raise completely the machine.

<b>MAINTENANCE INSTRUCTIONS</b>
---------------------------------

On diagram "A" the maintenances are indicated with their terms to effect on the machine.  
 Not follow the scheduled terms can compromise the functionality of the machine and in this case the warranty is not applicable.

**DIAGRAM "A" SCHEDULED MAINTENANCE**

	<b>FIRST START</b>	<b>AFTER 10 H.</b>	<b>EACH 30 H.</b>	<b>EACH 500 H.</b>	<b>END SEASON</b>	<b>START WORK</b>	<b>END WORK</b>
<b>MACHINE</b>	Greasing		Greasing		Cleaning Greasing		Cleaning
<b>GEAR BOX</b>	Oil level	Oil level	Oil level	Change oil			
<b>SCREW</b>		Screw	Screw				
<b>TOOLS</b>			Check		Check	Check	Check
<b>BELTS</b>		Check		Replacement			

## 1. GREASING

At the scheduled time on diagram "A", grease the 7 points "B" "C", "D", "E", "F", "G".  
Greasing point is equipped with greaser HYDRAULIC TYPE MODEL "A" UNI 7663.  
To greasing use only MULTIFUNCTIONAL GREASE LITHIUM BASED Type NLGI 2.

## 2. OIL CHECK - OIL REPLACEMENT IN GEAR BOX

At the scheduled time on diagram "A", check or replace oil into gear box.  
To fill oil use only OIL SAE 140 EP.  
Gear box capacity: 0,8 L

a) To check oil level into the gear box "A", operate as follow :

1. With the machine on level, remove the safety cover from the front side of the gear box, unscrew plug "TL" and check that oil touches on lower hole rim.
2. If the level is ok, screw plug "TL".
3. If the level is low, unscrew plug "TR" and refill.
4. When the level is ok, screw plug "TL" and "TR".

b) To change oil into the gear box "A", operate as follow :

1. Remove the safety cover from the front side of the gear box, unscrew plugs "TL", "TR" and the discharge plug "TS", wait until all oil has exited.
2. Screw the discharge plug "TS" then fill oil from plug "TR".
3. When level is ok, screw plugs "TL" and "TR" and assemble the safety cover.

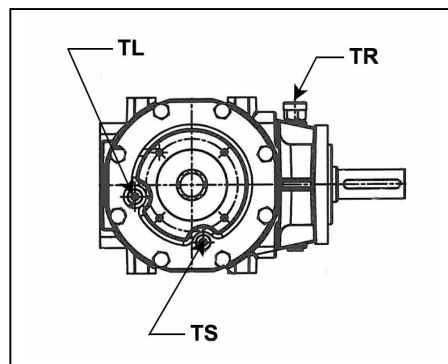
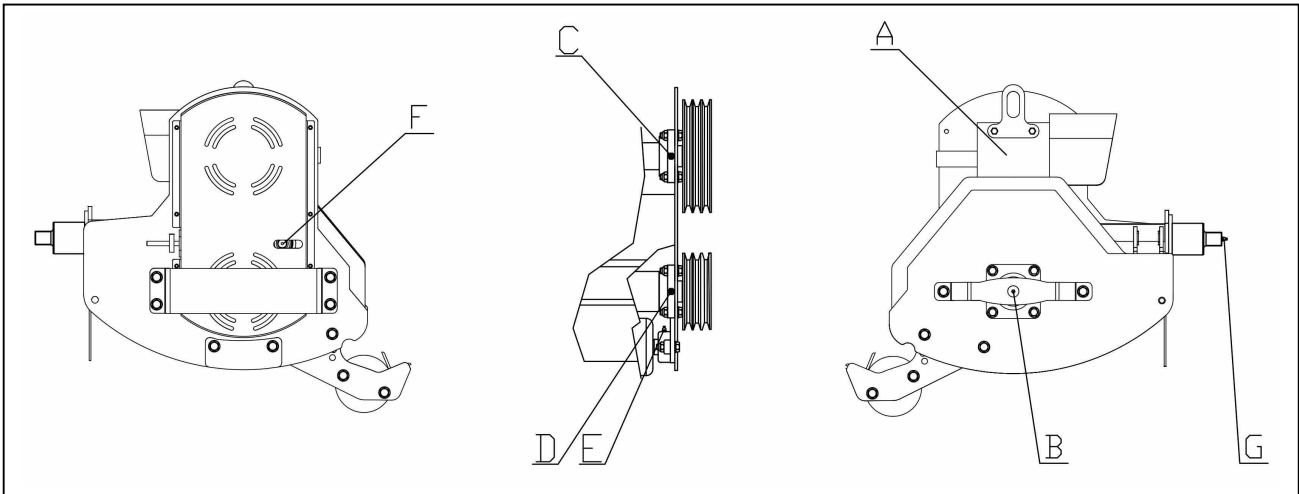

### 3. TOOLS REPLACEMENT

a) To change tools, operate as follow :

1. Unscrew the nut then take out the screw "B".
2. Take out tools "A" with bushes.
3. If tool is a hammer there are not bushes
4. Assemble the new tool.
5. Fit the screw "B" then screw the nut.
6. **ATTENTION: all tools must be of the same type.**
7. **ATTENTION: changing type of tools you must balance again the rotor.**

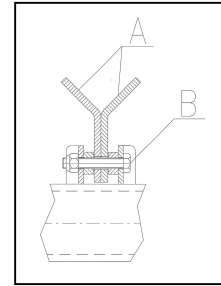

### 4. BELTS ADJUSTING AND REPLACEMENT

a) To adjust the tension of the transmission belts, operate as follow :

1. Disassemble safety protection "A" unscrewing the 8 screws "B".
2. Unscrew the lock nut "C", screw the nut "D" to increase or unscrew to decrease the tension.
3. After operation screw the lock nut "C" then assemble the safety protection "A".

b) To change the transmission belts, operate as follow :

1. Disassemble safety protection "A" unscrewing the 8 screws "B".
2. Unscrew the lock nut "C" and the nut "D"
3. Remove the old belts "E", to prevent adjusting problems you must replace all, and then assemble the new referring to the characteristics in the SPARE PART LIST.
4. Make operations "2" and "3" point "a".

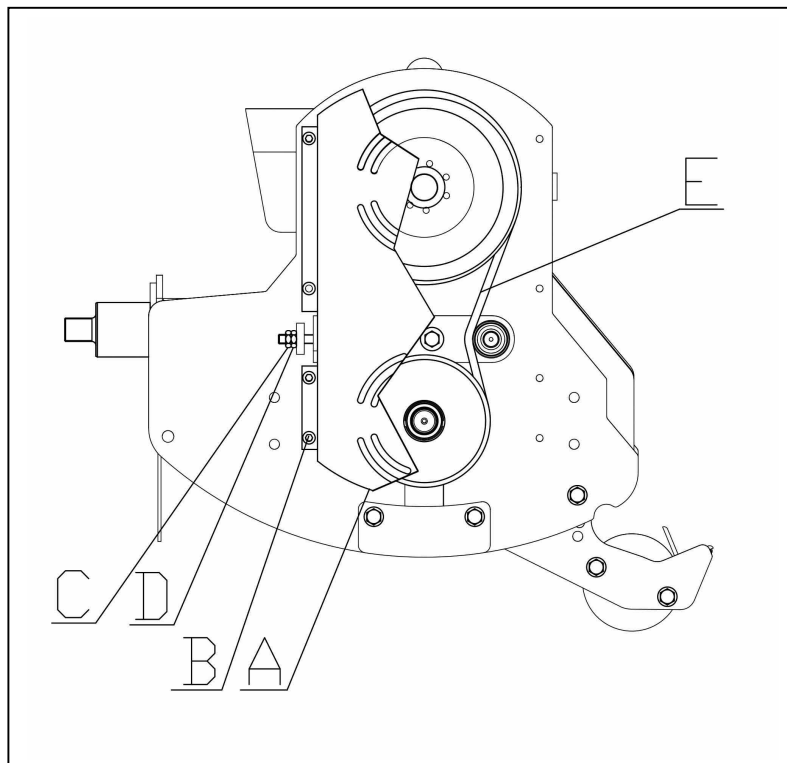

**PROBLEMS SOLVING**

<b>TROUBLES</b>	<b> GROUNDS AND SOLUTIONS</b>
<b>Abnormal vibrations</b>	-Not balanced rotor – Enquire a dealer. -Loss of one or more tools – Replace. -Damaged bearings – Replace.
<b>Uneven or unsatisfactory cut</b>	-Damaged tools – Replace. -Tools choice not good – Change with another type.



## TRANSPORT

Except when working, moving the machine takes place when the machine is standing still and the transmission is disconnected.

**<Important>**: keep speed low avoiding holes and ground roughness.

**<Important>**: Before begin the movements always make sure that the safety hooks be in position.

**<Note when** on the road, obey existing traffic laws. Exhibit the signal signs on the rear ends. Respect any local laws there may be.

## STORAGE

Store the machine in a dry place that isn't dusty.

## INFORMATION ON DEMOLITION



At the end of its working life, the machine must be sent to be demolished and that can only be done by an authorized authority, in accordance with the national laws in force for the environment. Therefore it is necessary to get information from the qualified local authorities on the procedure to follow. The machine is mainly composed of: iron materials and paints.

## WARRANTY

The machine is covered by the manufacturer warranty for a period of 24 months.

The warranty is not applicable when:

- a) The maintenance work has not been done correctly.
- b) The machine has been used out of its own service.
- c) The machine has been transformed or modified without the manufacturer's written authorization.



## **SPARE PARTS & OPTIONS**

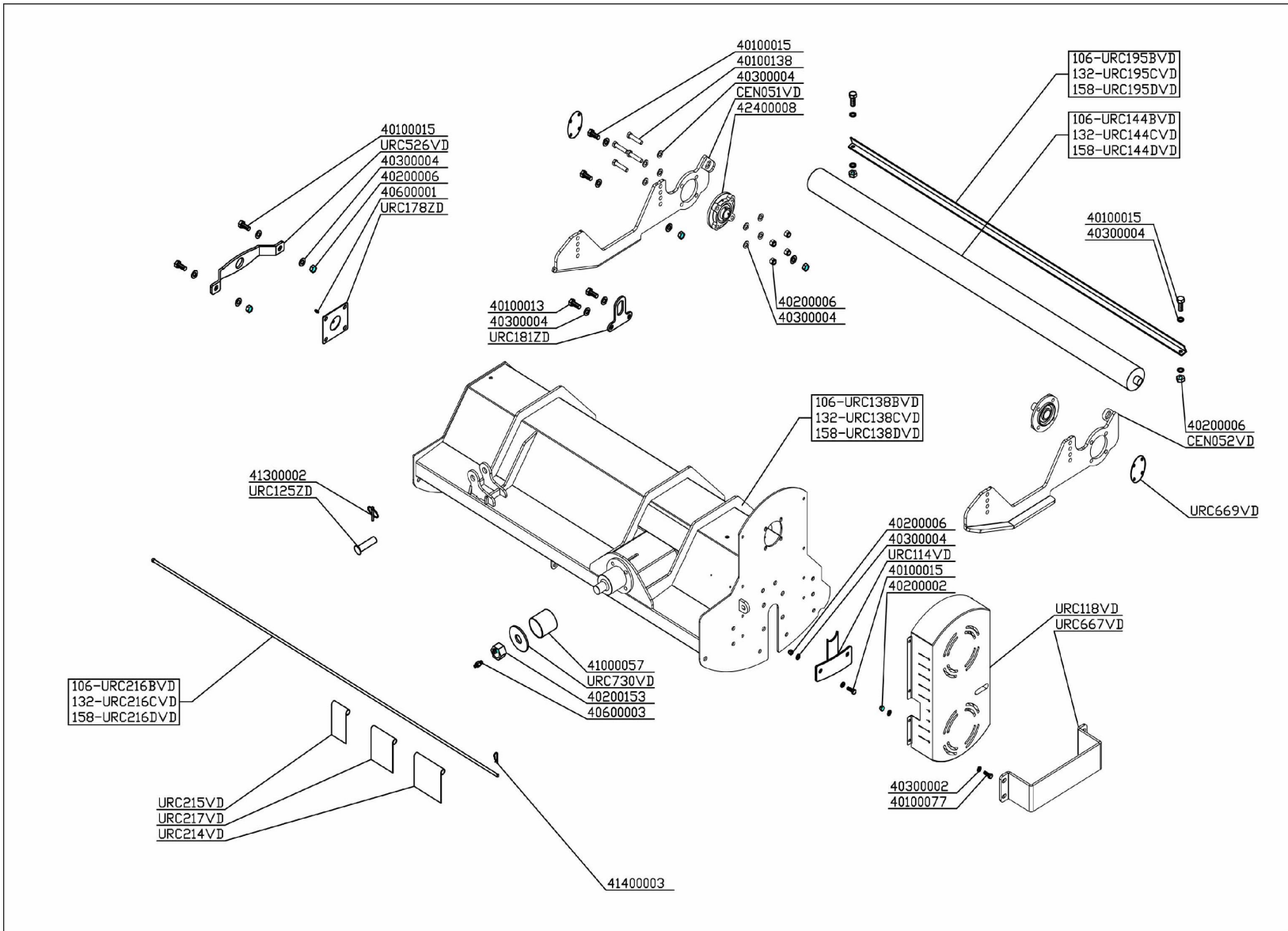

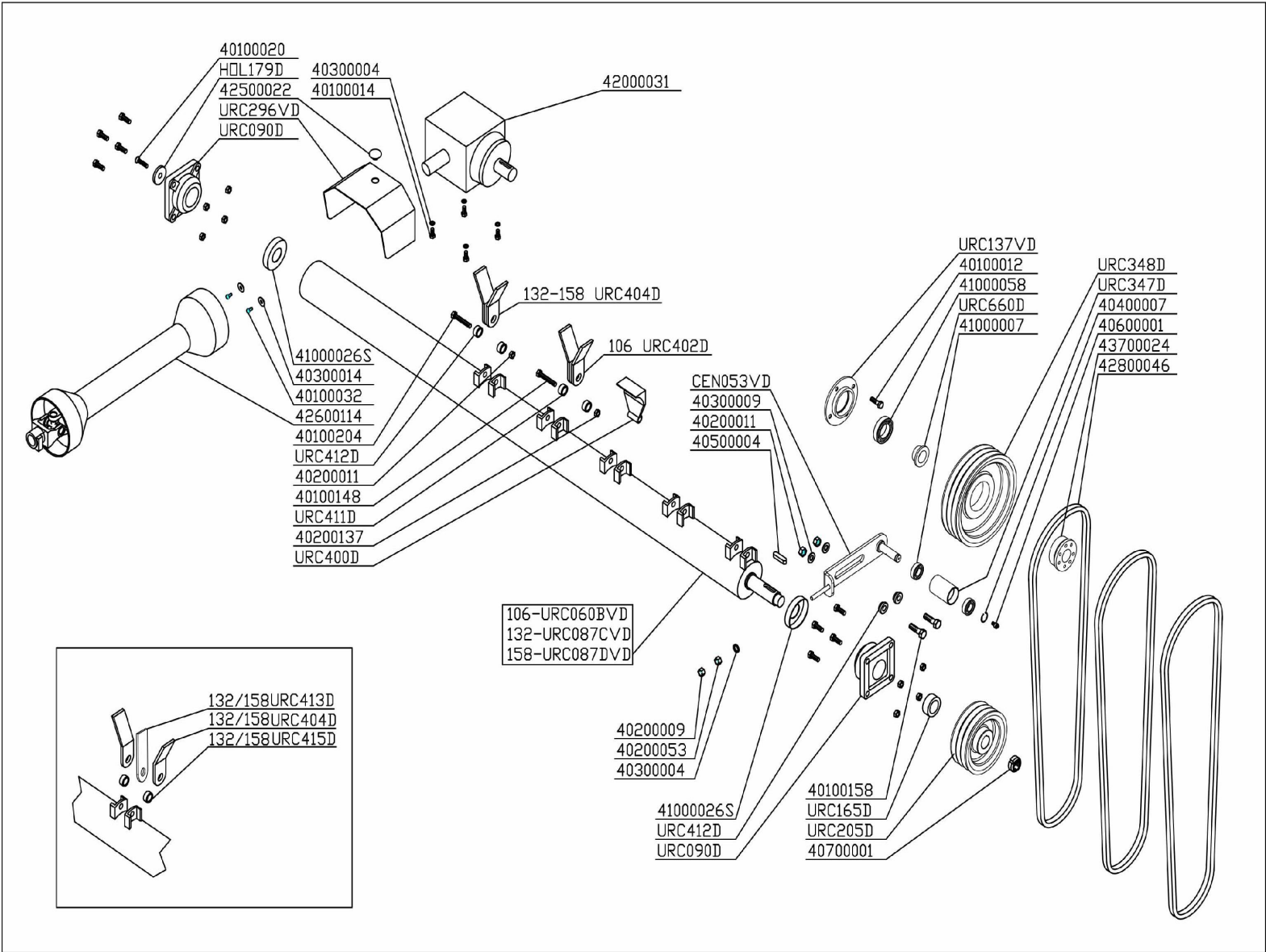

MECHANISM

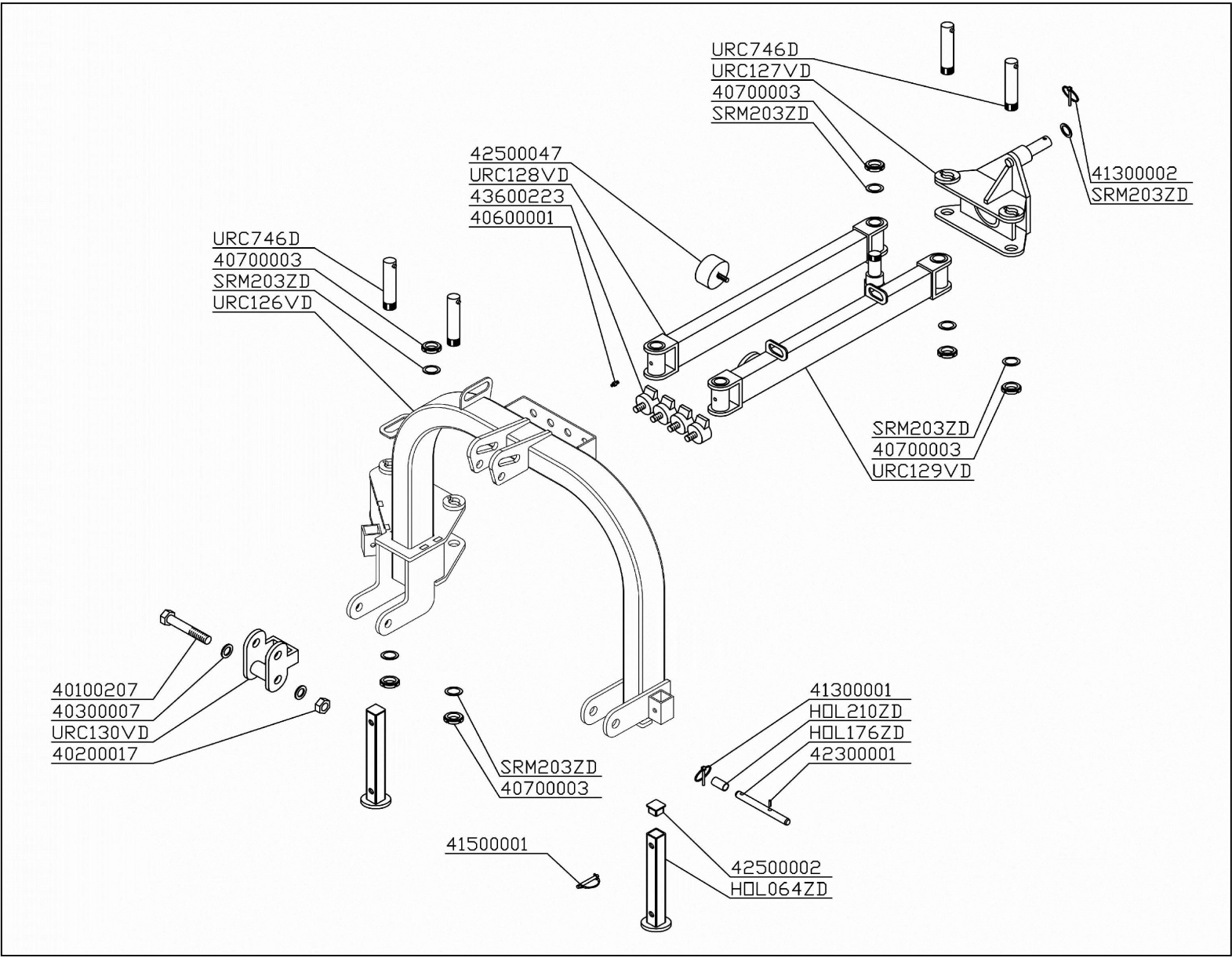

LINKAGE

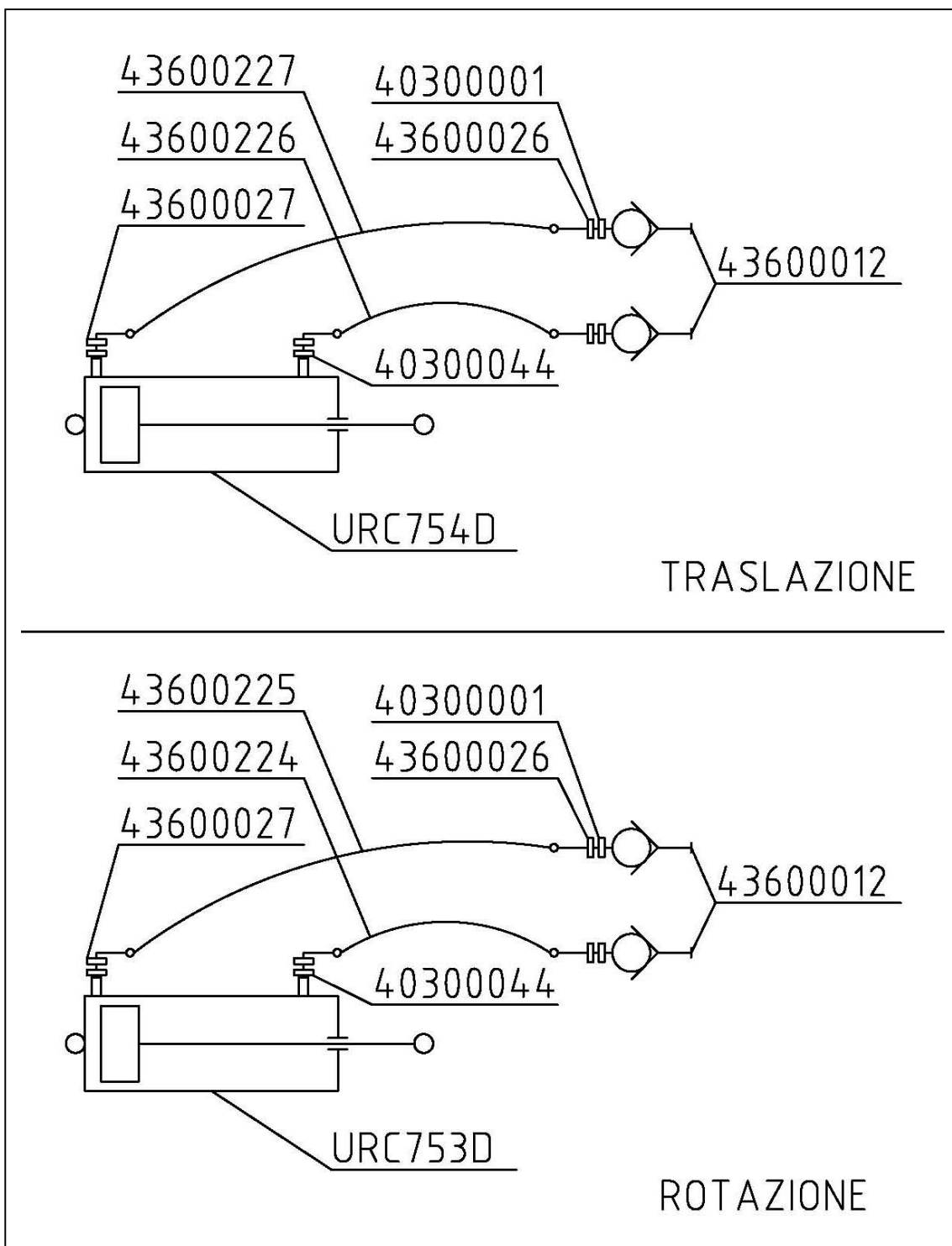

## INDEX

<b>PREFACE</b> .....	<b>2</b>
<b>DESCRIPTION</b> .....	<b>3</b>
FUNCTION OF USE .....	3
PERFORMANCES .....	3
PERFORMANCES LIMIT .....	3
STANDARD EQUIPMENTS .....	3
VARIANT & OPTIONS .....	3
<b>TECHNICAL SPECIFICATIONS</b> .....	<b>4</b>
<b>SAFETY INFORMATIONS</b> .....	<b>2</b>
PRESCRIZIONI GENERALI .....	2
SAFETY RESTRICTIONS .....	2
RUNNING IN .....	2
<b>SAFETY SIGNS ON THE MACHINE</b> .....	<b>3</b>
<b>INSTRUCTIONS FOR USE</b> .....	<b>4</b>
1. BEFORE BEGINNING WORK .....	4
2. TO BEGINNING WORK .....	5
3. AT THE END OF CUTTING OPERATION .....	5
<b>MAINTENANCE INSTRUCTIONS</b> .....	<b>6</b>
DIAGRAM "A" SCHEDULED MAINTENANCE .....	6
1. GREASING .....	7
2. OIL CHECK - OIL REPLACEMENT IN GEAR BOX .....	7
3. TOOLS REPLACEMENT .....	8
4. BELTS ADJUSTING AND REPLACEMENT .....	8
<b>PROBLEMS SOLVING</b> .....	<b>9</b>
<b>TRANSPORT</b> .....	<b>10</b>
<b>STORAGE</b> .....	<b>10</b>
<b>INFORMATION ON DEMOLITION</b> .....	<b>10</b>
<b>WARRANTY</b> .....	<b>10</b>
<b>WORK AND MAINTENANCE SHEET</b> .....	<b>11</b>
<b>SHEETS</b> .....	<b>13</b>
<b>MECHANISM</b> .....	<b>14</b>
<b>LINKAGE</b> .....	<b>15</b>
<b>HYDRAULIC PLANT</b> .....	<b>16</b>



