

*Tecnologia robusta  
Taglio delicato*



**USER AND MAINTENANCE MANUAL FLAIL MOWERS**



**ENGLISH**

**Code MUM-FRTML-EN-US\_Rev-00 Date: 22-11-2007**

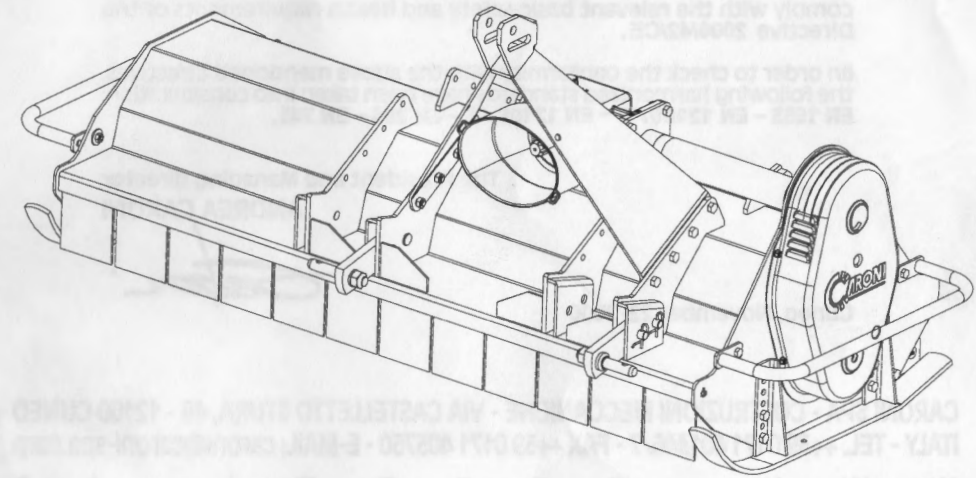

CARONI SPA  
VIA CASTELLETTO STURA, 46 - 12100 CUNEO  
TEL. 0171.401346/7 - FAX 0171.403750  
<http://www.caroni.it>  
e-mail: [caroni@caroni.it](mailto:caroni@caroni.it)





**CE** DECLARATION OF CONFORMITY



According to Directive 2006/42/CE as further modified

We

**CARONI S.P.A.**,  
Via Castelletto Stura 46  
I - 12100 CUNEO - ITALY,

Declare under our own responsibility that the following models of our rotary mowers:

### REAR FLAIL MOWERS

TL0900/TL1200/TL1500/TM1300/TM1600/TM1900

### FRONT FLAIL MOWERS

FTL0900/FTL1200/FTL1500/FTM1300/FTM1600/FTM1900

### FRONT & REAR FLAIL MOWERS

FRTL0900/FRTL1200/FRTL1500/FRTM1300/FRTM1600/FRTM1900

comply with the relevant basic safety and health requirements of the Directive 2006/42/CE.

In order to check the conformity with the above mentioned directives, the following harmonized standards have been taken into consideration:  
EN 1553 - EN 12100/1 - EN 12100/2 - EN 294 - EN 745.

The President and Managing director  
**ANDREA CARONI**

Cuneo, November 22, 2006

CARONI SPA - COSTRUZIONI MECCANICHE - VIA CASTELLETTO STURA, 46 - 12100 CUNEO  
ITALY - TEL. ++39 0171 401346/7 - FAX ++39 0171 403750 - E-MAIL: caroni@caroni-spa.com

w w w . c a r o n i . i t

## INDEX

1	Declaration of conformity	page
2	Marking and identification	page 2
2.1	Marking	page 2
2.2	Warning pictograms	page 2
2.3	Aerial noise and technical test data	page 3
2.4	Third point hitch categories	page 3
3	Conditions and limits of use	page 3
4	Use in safety	page 5
5	Startup	page 6
5.1	Commissioning	page 7
5.2	Adjustment of belt tension and cutting height	page 7
6	Maintenance	page 7
6.1	Oil quantity and greasing	page 8
6.2	Tire replacement	page 8
7	Transport and Storage	page 8
8	Technical features and available models	page 10
9	Figures 1 to 4	page 11-13

## FOREWORD

CARONI SPA would like to thank you for your preference in choosing our quality machines. Aiming at obtaining the longest possible efficiency of the machines you have purchased, we kindly invite you to read and thoroughly understand the instructions for use and maintenance in this manual. A careful compliance with these instructions permits to prevent troubles and accidents or injuries caused by carelessness or lack of compliance with the safety standards and in that case our company shall not be held liable.

This manual complies with the requirements of the machine directive 98/37/EC. The manual is integral with the machine and shall therefore accompany the machine should it be sold to a new user.



The presence of this symbol of danger in the manual points out important instructions concerning safety. It is first of all meant for the operator. The operator shall comply with the compliance with the warning contained in the message by himself but also by other people exposed to the machine risks. Lack of compliance with the instructions can cause damage to people which could sometimes even be cause of death.



This "instruction" symbol in the manual points out important instructions concerning the correct startup, operation and in general conditions which could jeopardize the life of the product.

The instructions contained in this manual should be read carefully before carrying out any operation with and on the machine, in order to work in safety and preserving its correct operation.



Apart from the main technical and safety features of the machines, the manufacturer reserves the right of carrying out modifications to the machine at any time for reasons of ongoing technical and technological evolution without having to be fined for that.

Furthermore we stress the fact that the only expected use of this machine is the one described in the manual. Any other application is forbidden.

## 2 – MARKING AND IDENTIFICATION

### 2.1 Marking

Each machine bears the EC identification label (for its position see fig.4), which contains not only the EC mark but also the following data:

- A - Name of the manufacturer
- B - Model
- C - Serial number
- D - Year of manufacture
- E - EC mark of conformity
- F - Mass in kg



### 2.2 Warning pictograms



The following warning pictograms can be found on the machine (see fig.4)

- 1 **Identification signal:** indicates the data relevant to the machine.
- 2 **Indication signal:** indicates the direction of rotation of the machine.
- 3 **Warning signal:** indicates it is necessary to fill the reduction unit with oil when the piece of equipment is used for the first time.
- 4 **General danger:** before any intervention, read the manual carefully.
- 5 **Warning signal:** indicates the rpm of the power takeoff.
- 6 **Danger of limb shearing:** do not insert your limbs within moving parts. Anyway before any intervention make sure the tractor engine is off.
- 7 **Danger of object projection:** keep at safety distance while working.
- 8 **General danger:** do not remove guards when parts are in motion.
- 9 **General danger:** do not climb on machine when parts are in motion.

### 2.3 Aerial noise and technical test data

Type of machine	FTL-TL-FRTL 0900	FTL-TL-FRTL 1200	FTL-TL-FRTL 1500	FTM-TM-FRTM 1300	FTM-TM-FRTM 1600	FTM-TM-FRTM 1900
PTO RPM	540	540	540	540	540	540
Engine RPM	2000	2000	2000	2000	2000	2000
Tractor power supply	Diesel oil	Diesel oil	Diesel oil	Diesel oil	Diesel oil	Diesel oil
Tractor KW	37	37	37	37	37	37
Lpa (dBA)	89	89	89	89	89	89
Lwa (dBA)	106	106	106	106	106	106

Acoustic power has been measured according to pos. D4 and D5 of EN standard 1553

Acoustic pressure has been determined analytically by means of acoustic power at a distance defined by pos. D.2.2.4 a) of EN standard 1553

### 2.4 Third point hitch categories

#### CATEGORY 1:THIRD POINT HITCH

REAR FLAIL MOWERS..... TL0900 / TL1200 / TL1500 / TM1300 / TM1600 / TM1900

FRONT FLAIL MOWERS..... FTL0900 / FTL1200 / FTL1500 / FTM1300 / FTM1600 / FTM1900

FRONT AND REAR FLAIL MOWERS...FRTL / FRTL1200 / FRTL1500 / FRTM1300 / FRTM1600 / FRTM1900



## 3 – CONDITIONS AND LIMITS OF USE



The destination of use of the flail mowers is finalized to cultivating the ground through a series of mechanical parts (tines) rotating on a horizontal axis parallel with the ground.

The machine is designed to be connected exclusively with the three-point hitch of a tractor and driven by the PTO mounted on the tractor.

Choose the tractor based on the power, loads, and overhang given in the table by using the data declared by the tractor manufacturer.

Any use apart from the specified one shall be considered improper, very dangerous and therefore prohibited. In particular we wish to highlight the fact that it is forbidden to use the machine to carry people, animals or loads.

For all the operations of use, adjustment and maintenance a single operator will be enough.



The presence of other people during the operations for linking the piece of equipment to the tractor is allowed only when the PTO is detached, the tractor engine is off and the brake is pulled. In fact in such a situation do not displace the tractor but the mower, by using a suitable piece of equipment.

Should it be impossible to find the data useful to choose the right tractor, the user shall make sure or have someone check that suitable safety margins are applied at work, the max. load limit on the axles is not exceeded and the braking ability is still adequate.

type of machine (FTL-M / FRTL-M / TL-M)	0900	1200	1500	1300	1600	1900
Mass (Kg)	195	218	228	261	293	318
Position of the barycenter in working conditions (mm) "X"	463	463	463	463	463	463
Position of the overhang in working conditions (mm) "Y"	860	860	860	860	860	860
Position of the barycenter in transfer conditions (mm) "X1"	433	433	433	433	433	433
Position of the overhang in transfer conditions (mm) "Y1"	830	830	830	830	830	830

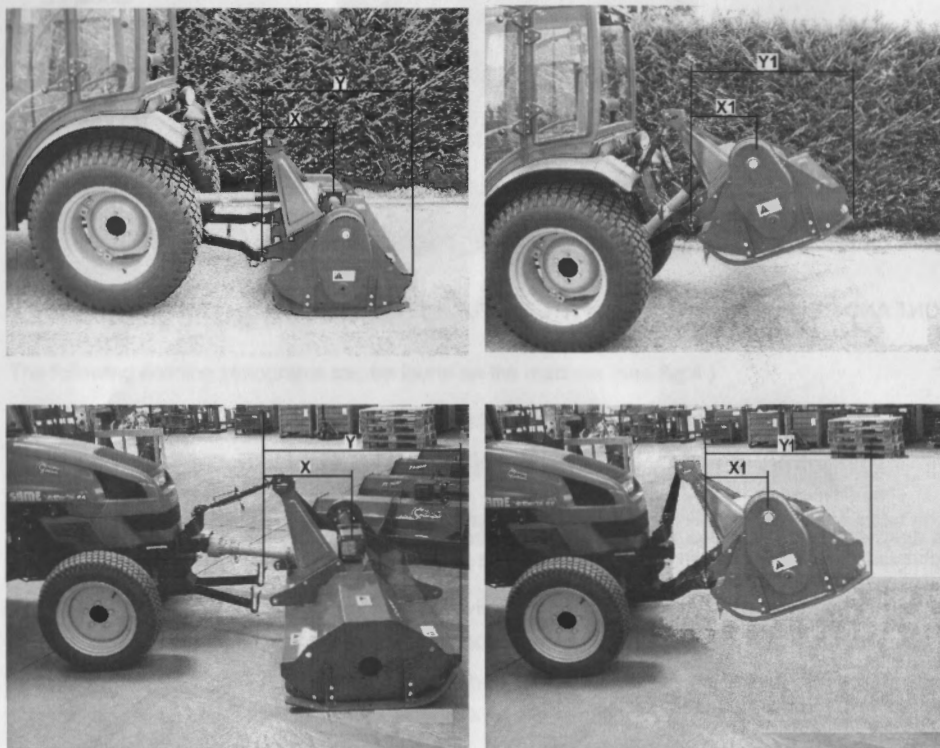

#### 4 – USE IN SAFETY CONDITIONS



Most accidents that take place at work, maintenance operations and machine displacement are due to lack of compliance with the most elementary norms of accident prevention. Therefore it is essential for those who are authorized to use the machines to read and thoroughly follow both the instructions below and the stickers applied to the machine.

1. Read this manual carefully before carrying out any operations for use, adjustment and maintenance.
2. Always stop the tractor engine, wait until all moving parts have stopped and detach the PTO shaft, before carrying out any operations for adjustment, maintenance or cleaning. Always rest the machine on the ground or on strong stands. Never lay down under the machine without these stands or without checking the stability of the machine.
3. Before use always make sure the screws or the nuts are tight, especially for blades or tines.
4. Always work with guards mounted, both on machine and on PTO shaft. Should the guards be damaged they should be replaced at once.
5. Keep anyone and all animals away before starting your machine. The dangerous area extends 15 meters around the machine.
6. Be particularly careful when working along roads or paths because of the possible projection of stones. Never exceed the prescribed slopes when using your tractor and always avoid particularly steep working areas.
7. Operate with suitable lighting only
8. A tractor with a cabin to protect the operator should be preferred.
9. Do not let the machine run unattended.
10. During checks and repairs make sure no one can start the machine accidentally.
11. Wear tight clothes without any loose parts which could be caught in moving parts or in the machine rotating parts. Wear accident prevention shoes, and wear gloves if you have to handle blades or parts with sharp edges. In case of extended use and on a tractor with no cabin use suitable sound deadening devices (ear plugs or head sets)
12. Do not carry people or property on the machine or tractor at work or during a road transfer.
13. The PTO shaft guards shall always be in good operating conditions at work and fixed with the safety chains preventing them from turning. Should the guards be damaged or worn, replace them immediately with other original guards.
14. For circulating on public roads, the operator shall make sure his/her machine complies with the current highway code and shall personally comply with the current standards in force in their country scrupulously.
15. For your safety and that of any third parties and not to make the guarantee null and void, use original spare parts only. Use the required personal protection means at all times.
16. Mind the dangers any rotating tools may cause.
17. Always use the machine on a grassy ground. Stop the gearbox to stop the tines for transportation or when crossing areas with no grass.
18. CARONI SPA shall not be liable for lack of compliance with these standards.



**5 - STARTUP**

Carry out all the operations for startup when the tractor engine is stopped, the PTO shaft is disconnected and all the transmission parts to the tools are stopped.

Before starting working fill the gearbox with oil HD 80 W 90 (see paragraph 6.1). When closing the cap do not tighten it too tight in order to prevent the gasket deformation which could generate oil leaks.

Check the direction of rotation and the rpm of the tractor and of the machine PTO, which shall necessarily be the same as the ones signaled on the machine next to the PTO with two yellow stickers.

**Danger:** it is forbidden to use the machine at a speed either than the one specified in the label.

Use only CE marked PTO shaft with guards.  
Once the machine has been hitched to the tractor, check the exact length of the PTO shaft.

In the various working positions, the PTO shaft transmission hoses shall telescopically insert of at least 150 mm as shown in the figure below.  
Repeat the check when the tool is hitched to a different tractor.

Any modifications to the PTO shaft are strictly prohibited. It is strictly prohibited to cut the PTO shaft in order to adapt its length.

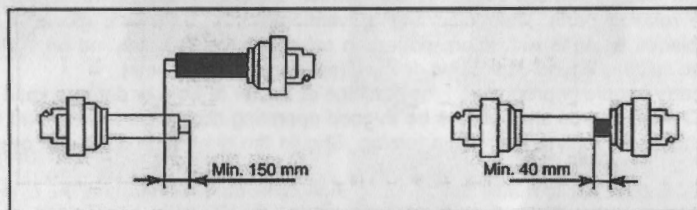

The PTO shaft guards shall be still and in good conditions while the PTO shaft rotates. Therefore only the pre-established chains shall be used. For your safety, when the PTO shaft guards are worn, they shall promptly be replaced. When the machine is not in service, to prevent the PTO shaft from resting on the ground, use the extra chain supplied in our kit rather than the two small rotation-proofing chains supplied with the PTO shaft. Never leave the PTO shaft on the ground. When the PTO shaft is being clutched in, make sure it is correctly locked in position.

**5.1 COMMISSIONING**

See picture nr. 1

- A. Position U-bolt "6" and tighten screws "7", washers "8" and nuts "9". For models with displaceable hitch, choose the position most suitable for your work.
- B. Place guards "2" (which shall never be removed for safety reasons) and for packaging cannot be mounted before shipment. Tighten them with screws "3" and washers "4". Place the plastic PTO guard "5" by interposing the preset reinforcement disc under the screws (**Guards "2" are necessary and demanded for the CE European market only**).
- C. Fill the gearbox with oil as shown in the table on page 8 of the manual. Then grease points 1 with EP2 grease every 8 to 10 hours' work.

**5.2 ADJUSTMENT OF BELT TENSION AND CUTTING HEIGHT**

See picture nr. 2

A A correct stretch of the belts will let your machines run smoothly for their best performance. Every 10 hours' operation check the belt stretch carefully. Proceed as follows after switching the tractor engine off and waiting until all moving parts have stopped:

1. remove the guard
2. tighten nut "10" to stretch the belts, loosen it to loosen the belts.
3. Mount the guard back in place.

B Proceed as follows after switching the tractor engine off and waiting until all moving parts have stopped:

1. Lift and rest the machine on solid stands
2. Loosen and remove screws "11" and adjust the height by lowering shoe "12" and roller "13" to the same height
3. Repeat the operation on the opposite shoe. Remember that to be able to use the machine correctly, shoe "12" and roller "13" shall work at the same height. For packaging reasons the roller can be positioned higher.

**6 - MAINTENANCE**

Carry out all the operations for startup when the tractor engine is stopped, the PTO shaft is disconnected and all the transmission parts to the tools are stopped.

Once your work is over, wash the underframe thoroughly in order to keep the machine perfectly effective.

Use only original cutting tools in order to guarantee your safety and that of any third parties (also for guarantee purposes).



## 6.1 OIL QUANTITY AND GREASING

**i** Before starting working fill the gearbox with oil HD 80 W 90 After the first 40 hours' work change the oil of the gearboxes by draining them off the drain plug. Fill with oil of the prescribed type through the topping up cap and check the quantity of oil filled in on the level rod. See table below. Dispose of the exhaust oil according to the current regulations. Do not abandon them in the environment.

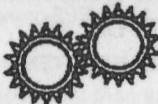
TIPO	Q.TÀ LITRI
SCATOLA INGRANAGGI TM-TL 	0,5

**i** Grease the points specified in pos. 1 fig. 1 every 10 to 12 hours. Use grease EP2.

## 7.2 TINE REPLACEMENT

See picture nr. 3

**!** **WARNING:** Before carrying out any intervention on the machine, make sure the tractor engine is off, the PTO shaft has been detached from the PTO and all moving parts have stopped.

A. To replace the blades proceed as follows:

1. Lift and rest the machine on solid stands
2. Loosen nut "14" and take out screw "15", position the new tines as shown by figure 3.
3. Tighten screw "15" and nuts "14".
4. Not to apply any stresses or useless vibrations to the machine, we recommend you replace all the tines at the same time.

B. Once your work is over, wash the underframe thoroughly in order to keep the machine perfectly effective.

**!** **WARNING:** Use original cutting tools only, in order to guarantee your safety and that of any third parties (also for guarantee purposes)

## 7 – TRANSPORT AND STORAGE

Transport can be carried out with different means also in view of the destination site.

To make transportation easier, shipment can be carried out after disassembling a few parts, duly protected and packed. While unpacking, check the integrity and correct quantity of the components. The packaging material shall be disposed of in compliance with the current laws.

**!** The personnel loading, unloading and handling the machine shall have abilities and experience acquired and acknowledged in this specific field.

**!** To take the machine out of its packaging material correctly, we recommend you use the 4 holes as shown in the figure below with bolts and belts required by the current standards relevant to load handling. If the machines are packed two by two use the 4 holes as shown in the figure below and loosen the coupling screw on the shoes. Before you loosen the screw, we recommend you make sure the machines rest on even ground to avoid shocks against the gearbox.

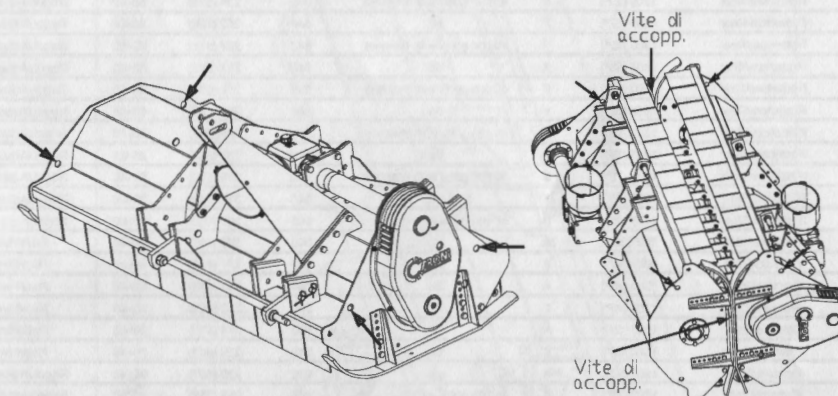

During the period when the machine is not used, carry out the cleaning and maintenance operations specified in chapter 6 of the manual and store the machine in a dry and sheltered place.

To transport the machine on public roads follow the highway code in force in your country.

ONLY IF YOU USE ORIGINAL SPARES,

**CARONI S.p.A.**

WILL ACKNOWLEDGE YOUR RIGHT TO GUARANTEE AND YOU WILL BE ABLE

TO OBTAIN THE BEST PERFORMANCE AND THE LONGEST LIFE OF THE MACHINE.



CARATTERISTICHE TECNICHE TRINCIABERBA TRINCIASTOCCHI SERIE TL-TM

TECHNICAL CHARACTERISTICS FLAIL MOWERS TL-TM SERIES

Codice macchina	Descrizione	Larghezza di taglio	Tipo di rotore	Nr. di coltelli	Nr. di giri presa di forza	Peso	Potenza trattore	Attacco
Machine code	Description	Cutting width mm (inch)	Type of rotor	N. blades	Pto speed	Weight Kg (lbs)	Tractor power HP	Hitch CAT. 1
TL0900ASC	Posteriore/Rear	900 (36")	A	28	540	182 (401)	20-40	Fissi/Fixed
TL0900FSC	Posteriore/Rear	900 (36")	F	56	540	187 (412)	20-40	Fissi/Fixed
TL1200ASC	Posteriore/Rear	1200 (48")	A	36	540	187 (412)	20-40	Fissi/Fixed
TL1200FSC	Posteriore/Rear	1200 (48")	F	72	540	210 (463)	20-40	Fissi/Fixed
TL1500ASC	Posteriore/Rear	1500 (59")	A	44	540	214 (472)	20-40	Fissi/Fixed
TL1500FSC	Posteriore/Rear	1500 (59")	F	88	540	220 (485)	20-40	Fissi/Fixed
TM1300ASC	Posteriore/Rear	1300 (52")	A	40	540	230 (507)	30-60	Regol./Adjustable
TM1300BSC	Posteriore/Rear	1300 (52")	B	40 con grillo/ with shackles	540	234 (516)	30-60	Regol./Adjustable
TM1300FSC	Posteriore/Rear	1300 (52")	F	80	540	253 (556)	30-60	Regol./Adjustable
TM1300PSC	Posteriore/Rear	1300 (52")	P	40 con grillo/ with shackles	540	234 (516)	30-60	Regol./Adjustable
TM1600ASC	Posteriore/Rear	1600 (63")	A	48	540	255 (562)	30-60	Regol./Adjustable
TM1600BSC	Posteriore/Rear	1600 (63")	B	48 con grillo/ with shackles	540	266 (586)	30-60	Regol./Adjustable
TM1600FSC	Posteriore/Rear	1600 (63")	F	96	540	285 (628)	30-60	Regol./Adjustable
TM1600PSC	Posteriore/Rear	1600 (63")	P	48 con grillo/ with shackles	540	266 (586)	30-60	Regol./Adjustable
TM1900ASC	Posteriore/Rear	1900 (75")	A	56	540	292 (644)	30-60	Regol./Adjustable
TM1900BSC	Posteriore/Rear	1900 (75")	B	56 con grillo/ with shackles	540	295 (650)	30-60	Regol./Adjustable
TM1900FSC	Posteriore/Rear	1900 (75")	F	112	540	310 (683)	30-60	Regol./Adjustable
TM1900PSC	Posteriore/Rear	1900 (75")	P	56 con grillo/ with shackles	540	295 (650)	30-60	Regol./Adjustable
FTL0900ASC	Frontale/Front	900 (36")	A	28	540	182 (401)	20-40	Fissi/Fixed
FTL0900FSC	Frontale/Front	900 (36")	F	56	540	187 (412)	20-40	Fissi/Fixed
FTL1200ASC	Frontale/Front	1200 (48")	A	36	540	187 (412)	20-40	Fissi/Fixed
FTL1200FSC	Frontale/Front	1200 (48")	F	72	540	210 (463)	20-40	Fissi/Fixed
FTL1500ASC	Frontale/Front	1500 (59")	A	44	540	214 (472)	20-40	Fissi/Fixed
FTL1500FSC	Frontale/Front	1500 (59")	F	88	540	220 (485)	20-40	Fissi/Fixed
FTM1300ASC	Frontale/Front	1300 (52")	A	40	540	230 (507)	30-60	Regol./Adjustable
FTM1300BSC	Frontale/Front	1300 (52")	B	40 con grillo/ with shackles	540	253 (556)	30-60	Regol./Adjustable
FTM1300FSC	Frontale/Front	1300 (52")	F	80	540	255 (562)	30-60	Regol./Adjustable
FTM1300PSC	Frontale/Front	1300 (52")	P	40 con grillo/ with shackles	540	253 (558)	30-60	Regol./Adjustable
FTM1600ASC	Frontale/Front	1600 (63")	A	48	540	266 (586)	30-60	Regol./Adjustable
FTM1600BSC	Frontale/Front	1600 (63")	B	48 con grillo/ with shackles	540	285 (628)	30-60	Regol./Adjustable
FTM1600FSC	Frontale/Front	1600 (63")	F	96	540	292 (644)	30-60	Regol./Adjustable
FTM1600PSC	Frontale/Front	1600 (63")	P	48 con grillo/ with shackles	540	285 (628)	30-60	Regol./Adjustable
FTM1900ASC	Frontale/Front	1900 (75")	A	56	540	292 (644)	30-60	Regol./Adjustable
FTM1900BSC	Frontale/Front	1900 (75")	B	56 con grillo/ with shackles	540	295 (650)	30-60	Regol./Adjustable
FTM1900FSC	Frontale/Front	1900 (75")	F	112	540	310 (683)	30-60	Regol./Adjustable
FTM1900PSC	Frontale/Front	1900 (75")	P	56 con grillo/ with shackles	540	295 (650)	30-60	Regol./Adjustable
FRTL0900ASC	Front-PostFront-Rear	900 (36")	A	28	540	190 (419)	20-40	Fissi/Fixed
FRTL0900FSC	Front-PostFront-Rear	900 (36")	F	56	540	195 (430)	20-40	Fissi/Fixed
FRTL1200ASC	Front-PostFront-Rear	1200 (48")	A	36	540	195 (430)	20-40	Fissi/Fixed
FRTL1200FSC	Front-PostFront-Rear	1200 (48")	F	72	540	218 (481)	20-40	Fissi/Fixed
FRTL1500ASC	Front-PostFront-Rear	1500 (59")	A	44	540	222 (489)	20-40	Fissi/Fixed
FRTL1500FSC	Front-PostFront-Rear	1500 (59")	F	88	540	228 (503)	20-40	Fissi/Fixed
FTM1300ASC	Front-PostFront-Rear	1300 (52")	A	40	540	236 (525)	30-60	Regol./Adjustable
FTM1300BSC	Front-PostFront-Rear	1300 (52")	B	40 con grillo/ with shackles	540	242 (534)	30-60	Regol./Adjustable
FTM1300FSC	Front-PostFront-Rear	1300 (52")	F	80	540	261 (575)	30-60	Regol./Adjustable
FTM1300PSC	Front-PostFront-Rear	1300 (52")	P	40 con grillo/ with shackles	540	242 (534)	30-60	Regol./Adjustable
FTM1600ASC	Front-PostFront-Rear	1600 (63")	A	48	540	263 (580)	30-60	Regol./Adjustable
FTM1600BSC	Front-PostFront-Rear	1600 (63")	B	48 con grillo/ with shackles	540	274 (604)	30-60	Regol./Adjustable
FTM1600FSC	Front-PostFront-Rear	1600 (63")	F	96	540	293 (646)	30-60	Regol./Adjustable
FTM1600PSC	Front-PostFront-Rear	1600 (63")	P	48 con grillo/ with shackles	540	274 (604)	30-60	Regol./Adjustable
FTM1900ASC	Front-PostFront-Rear	1900 (75")	A	56	540	300 (661)	30-60	Regol./Adjustable
FTM1900BSC	Front-PostFront-Rear	1900 (75")	B	56 con grillo/ with shackles	540	303 (668)	30-60	Regol./Adjustable
FTM1900FSC	Front-PostFront-Rear	1900 (75")	F	112	540	318 (701)	30-60	Regol./Adjustable
FTM1900PSC	Front-PostFront-Rear	1900 (75")	P	56 con grillo/ with shackles	540	303 (668)	30-60	Regol./Adjustable

Fig. n°1

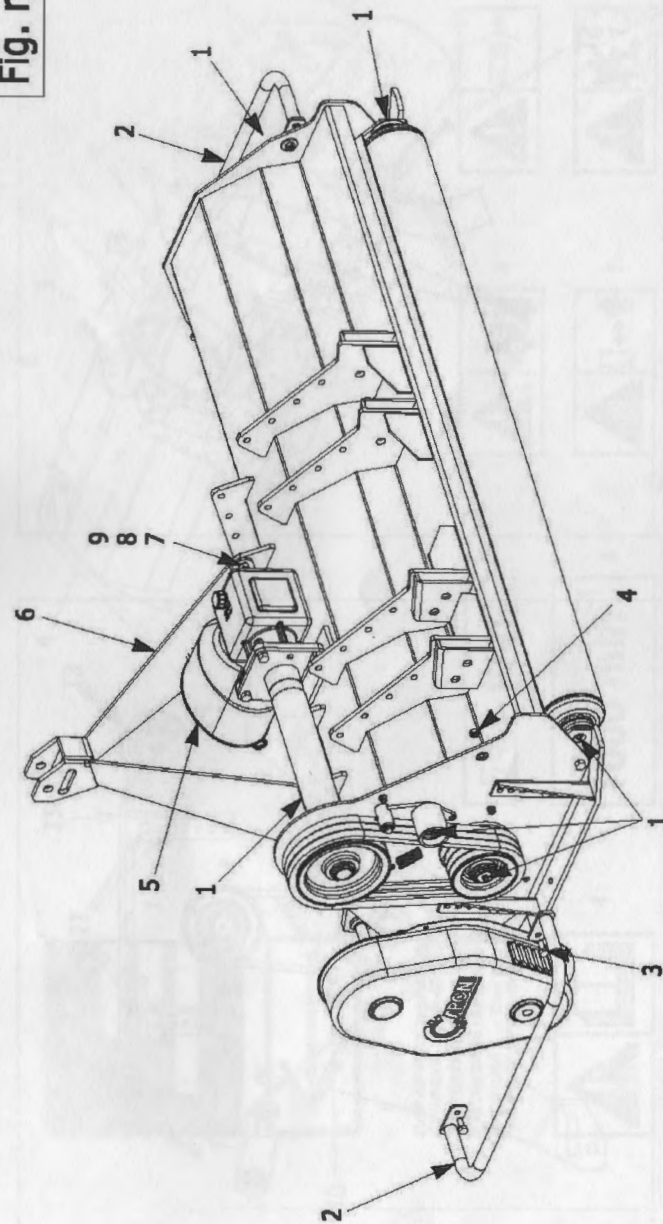



Fig. n°2

Fig. n°3

tractortoolsdirect.com

800 5. 9th Street, Terre Haute, IN 47807

(260) BALE-HAY

Page 12

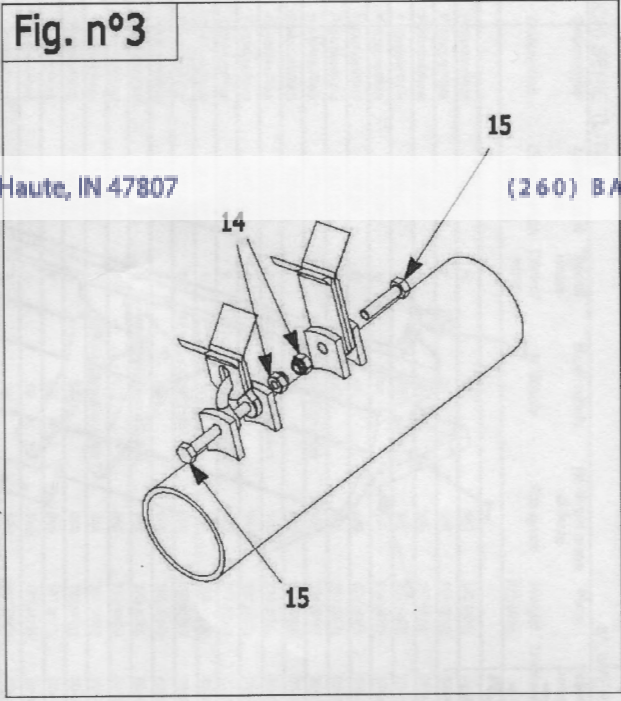
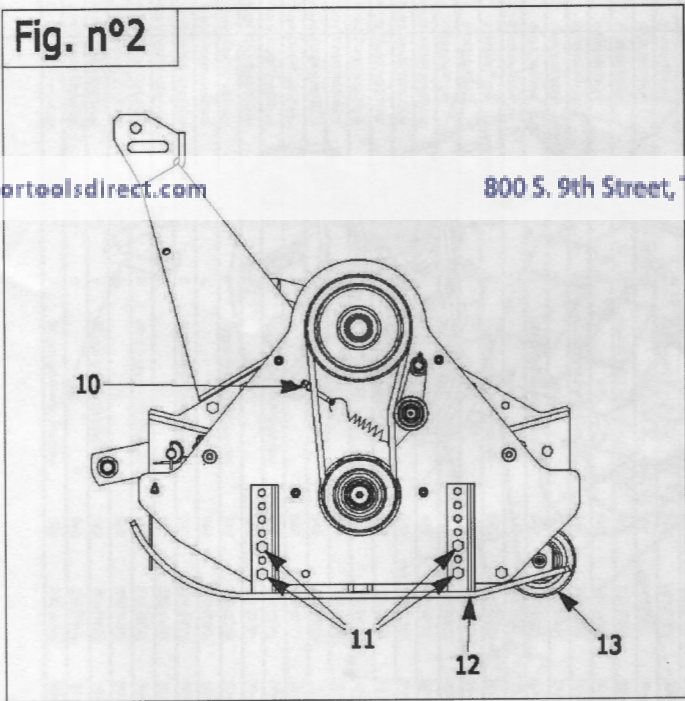

Page 13

Fig. n°4

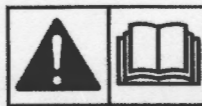
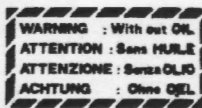
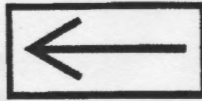

540 min<sup>-1</sup>

1000 min<sup>-1</sup>

